

NOTICE DE MONTAGE: Il est très important que vous suiviez phase par phase les instructions de montage !
 ASSEMBLY INSTRUCTIONS: It is very important that you follow step by step assembly instructions !
 LAS INSTRUCCIONES: Es muy importante que sigan paso a paso las instrucciones !
 MONTAGEPLAN: Het is zeer belangrijk de volgnummers van de handleiding te volgen !
 MONTAGEANLEITUNG: Es ist sehr wichtig, dass Sie die Montageanleitung der Reihe nach verfolgen !
 ISTRUZIONI DI MONTAGGIO: E 'molto importante seguire attentamente e passo per passo le istruzioni di montaggio!
 ИНСТРУКЦИИ ПО СБОРКЕ: Очень важно шаг за шагом точно следовать инструкции по сборке :
 MONTAJ KÝLAVUZU: Montaj kýlavuzunu sýrasý ile takip etmeniz çok önemlidir.

U01 - SUNDAY Façade Noyer U02 - SUNDAY Façade Chêne U03 - SUNDAY Façade Blanc Graphic

RANGEMENT BAS 2 PORTES
 REF.210

NF ENVIRONNEMENT AMEUBLEMENT
www.nf-environnement-ameublement.com

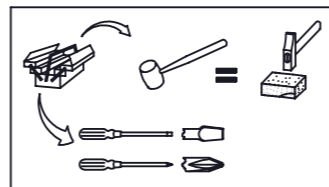
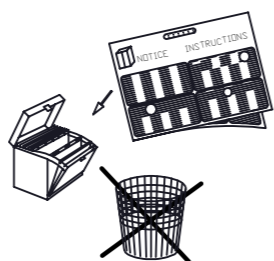

- 4 x Réf. 44663
- 4 x Réf. 56037
- 4 x Réf. 44528
- 2 x Réf. 55556
- 1 x Réf. 50185
- 4 x Réf. 56038
- 1 x Réf. 50176
- 4 x Réf. 44520
- 1 x Réf. 6519
- 1 x Réf. 45468
- 3 x Réf. 12297
- 8 x Réf. 28620
- 8 x Réf. 11573
- 2 x 14 mm Réf. 7874
- 2 x 15 mm Réf. 5397
- 3 x 25 mm Réf. 1396
- 16 x 25 mm Réf. 1391
- 4 x 25 mm Réf. 2352
- 8 x 35 mm Réf. 533
- 8 x Réf. 54469

REF. U01.210 Façade noyer
 REF. U02.210 Façade chêne

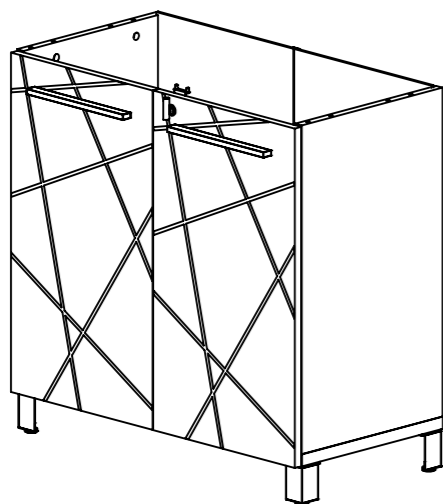
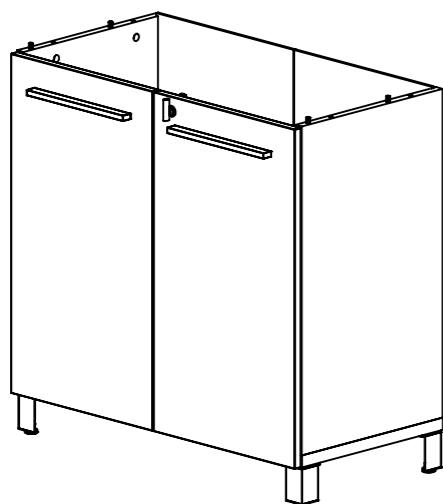

TOP NOYER Réf: U01.100

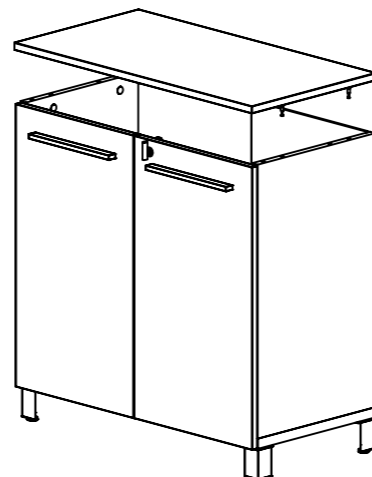

B1

TOP CHENE Réf: U02.100

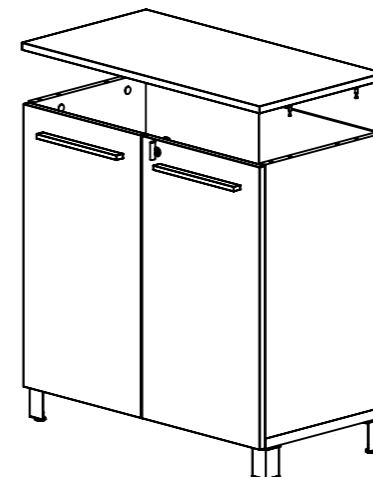

B2

TOP GRIS Réf: U03.100

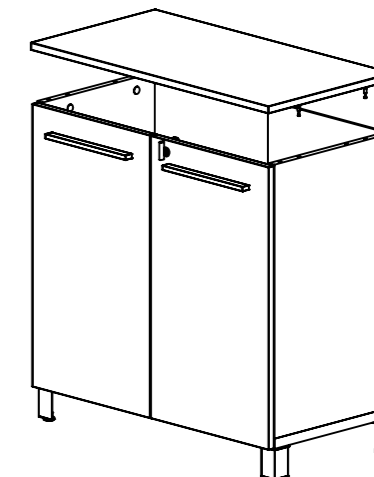

REF. U03.210 Façade Blanc graphic

SURMEUBLE MANDARINE Réf: U01.340
 KIWI Réf: U01.440
 PERLE Réf: U01.540

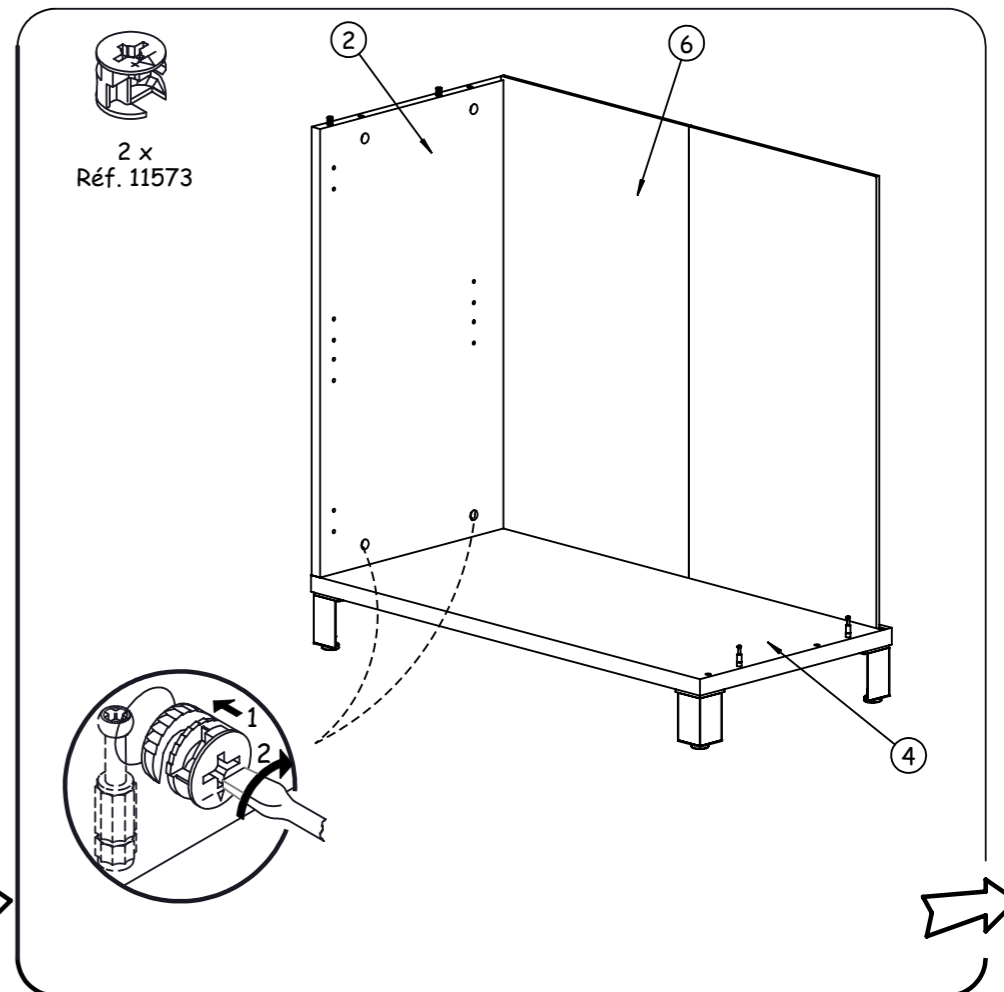
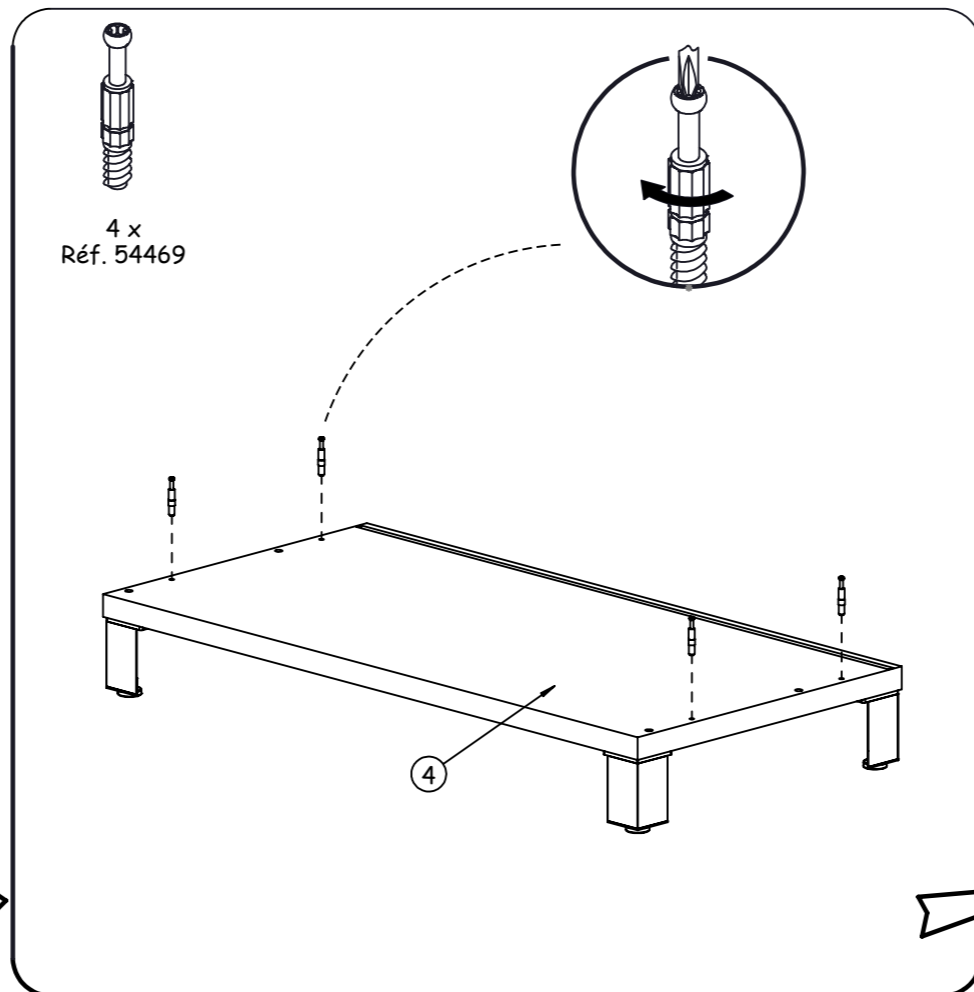
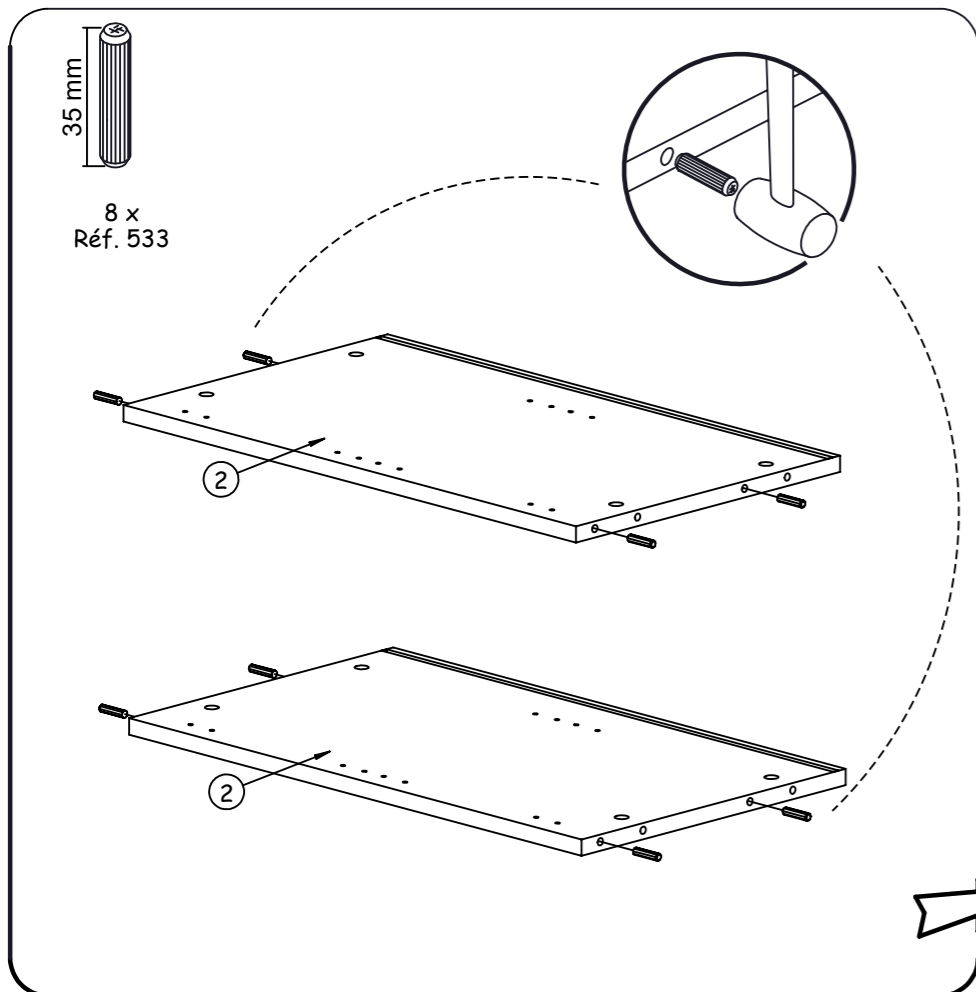
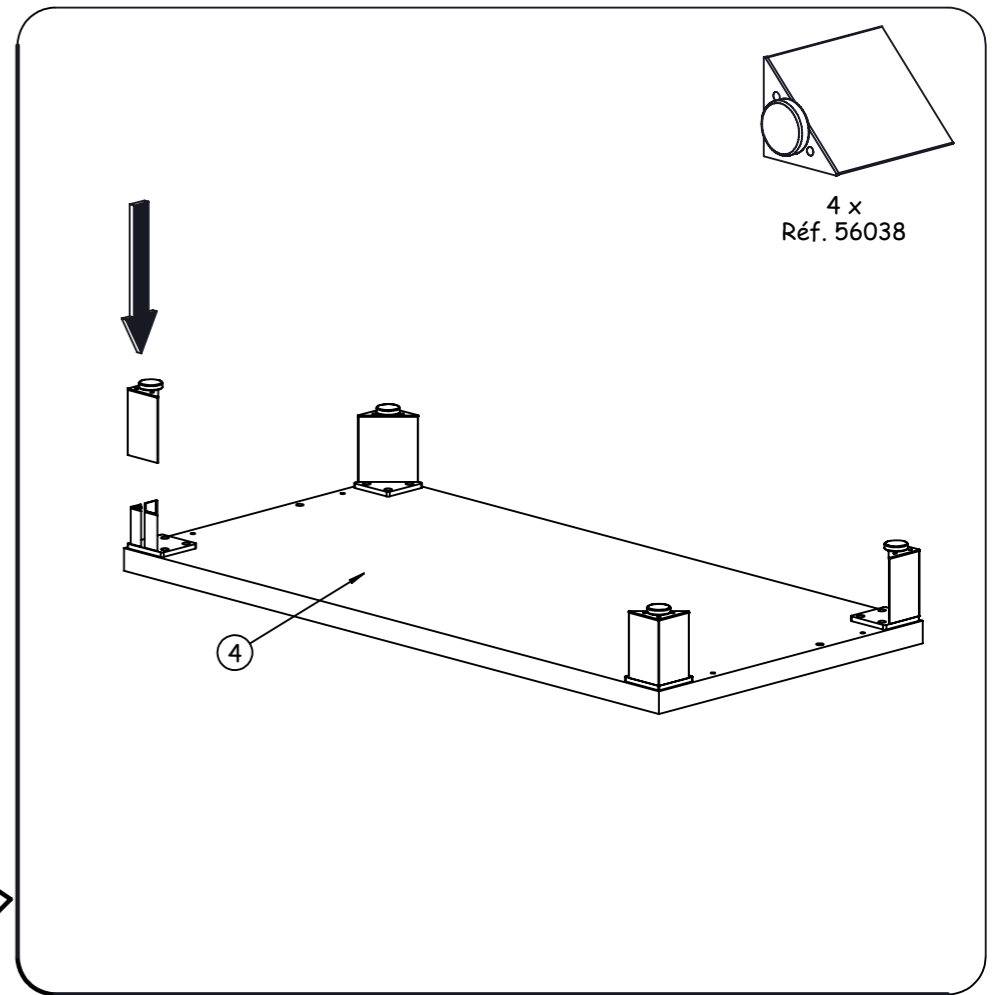
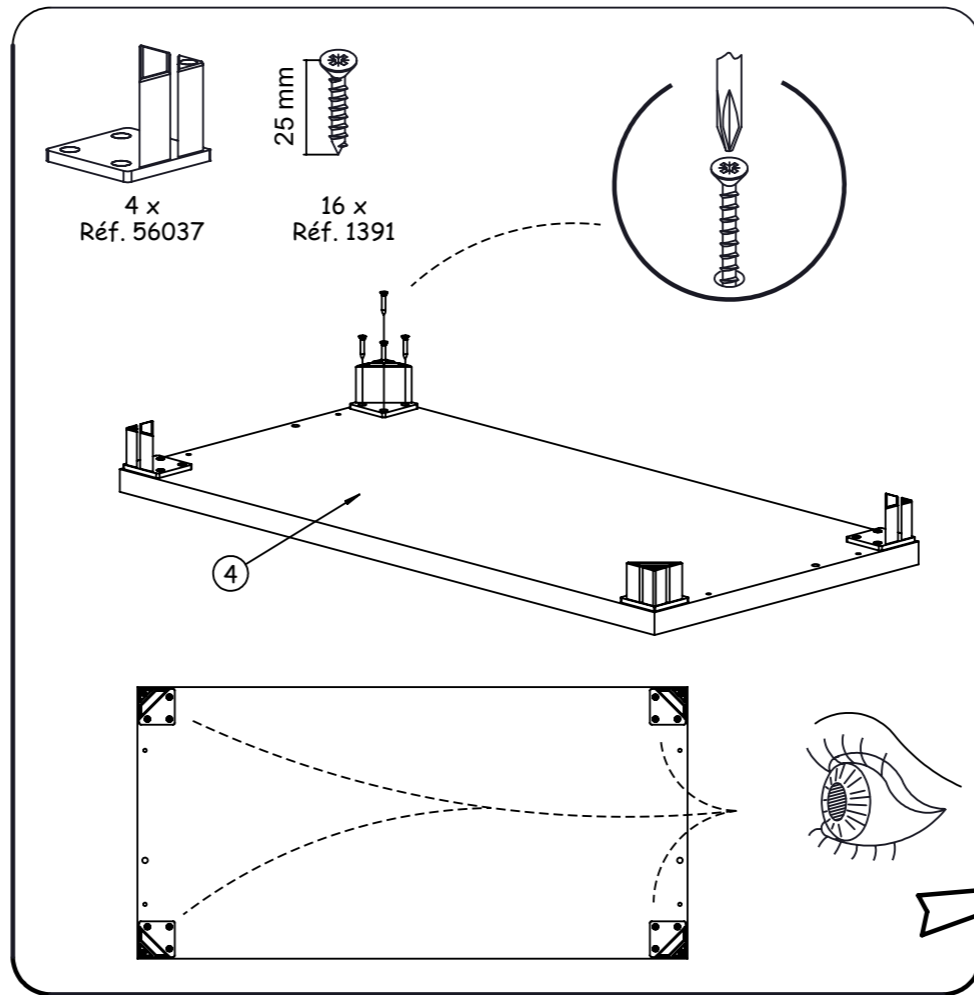
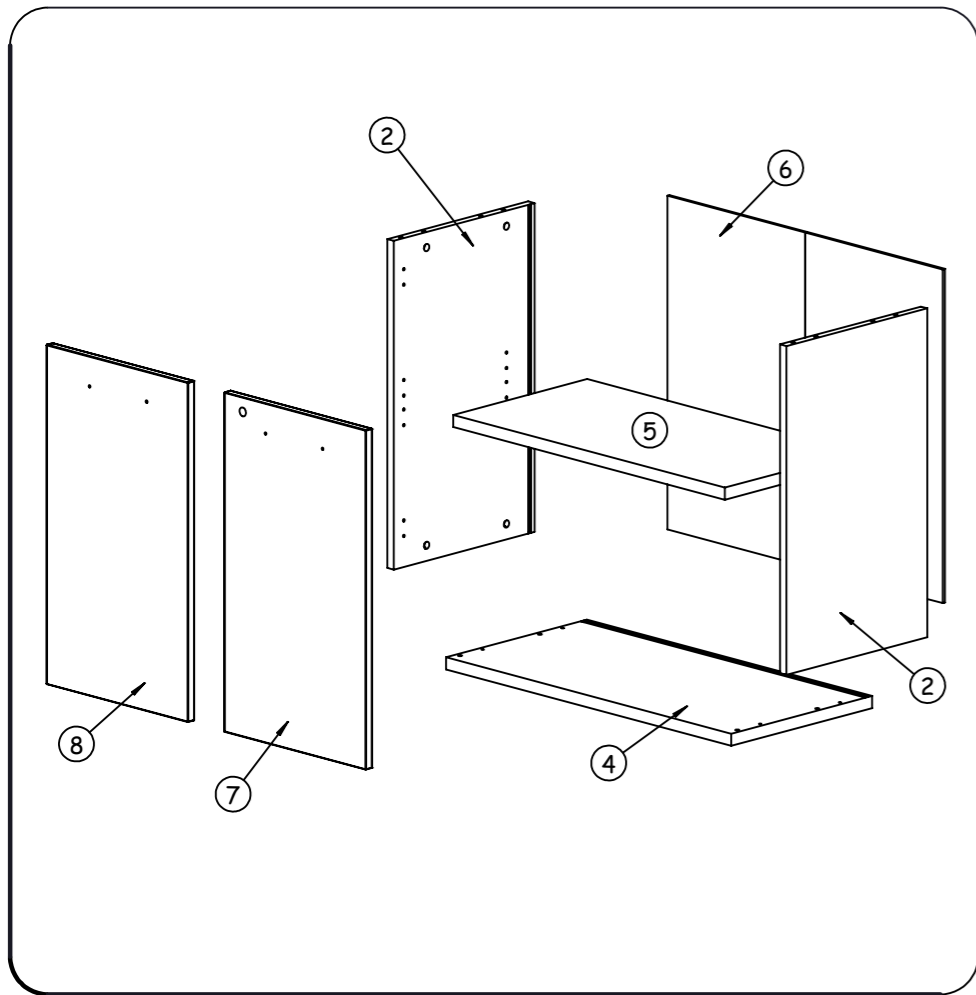

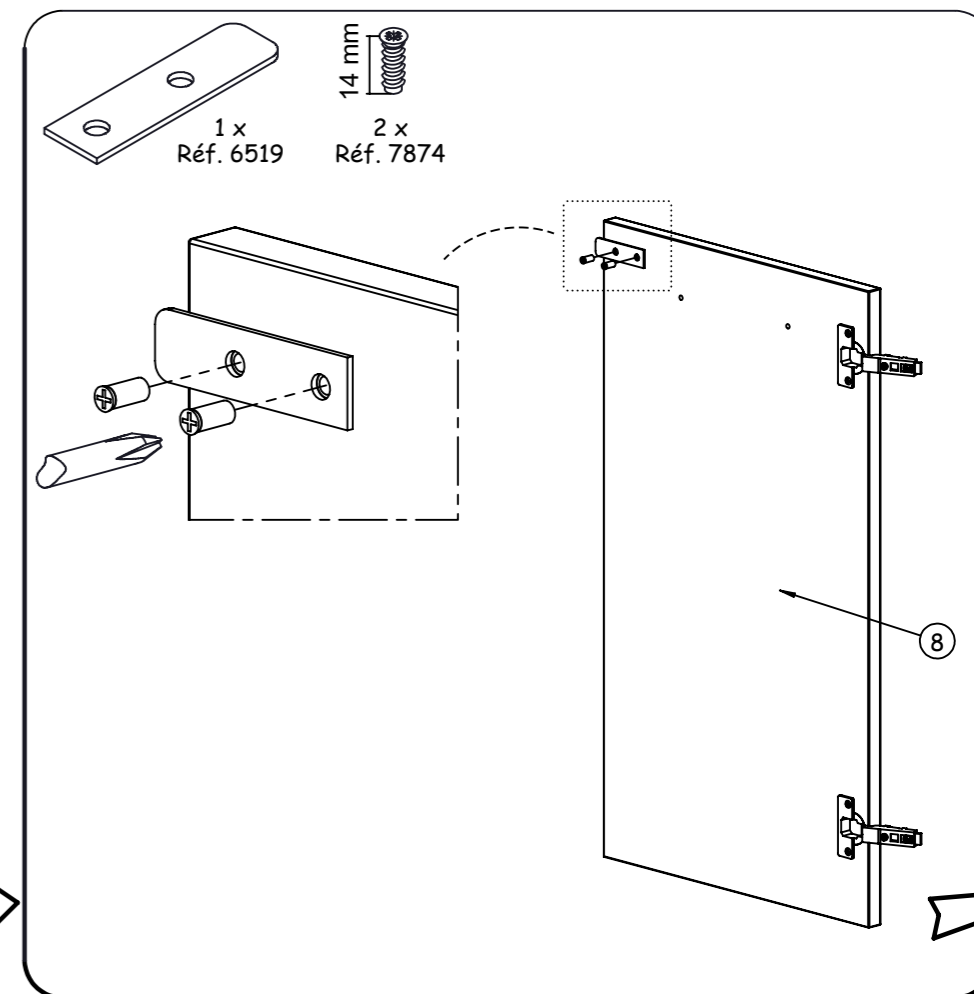
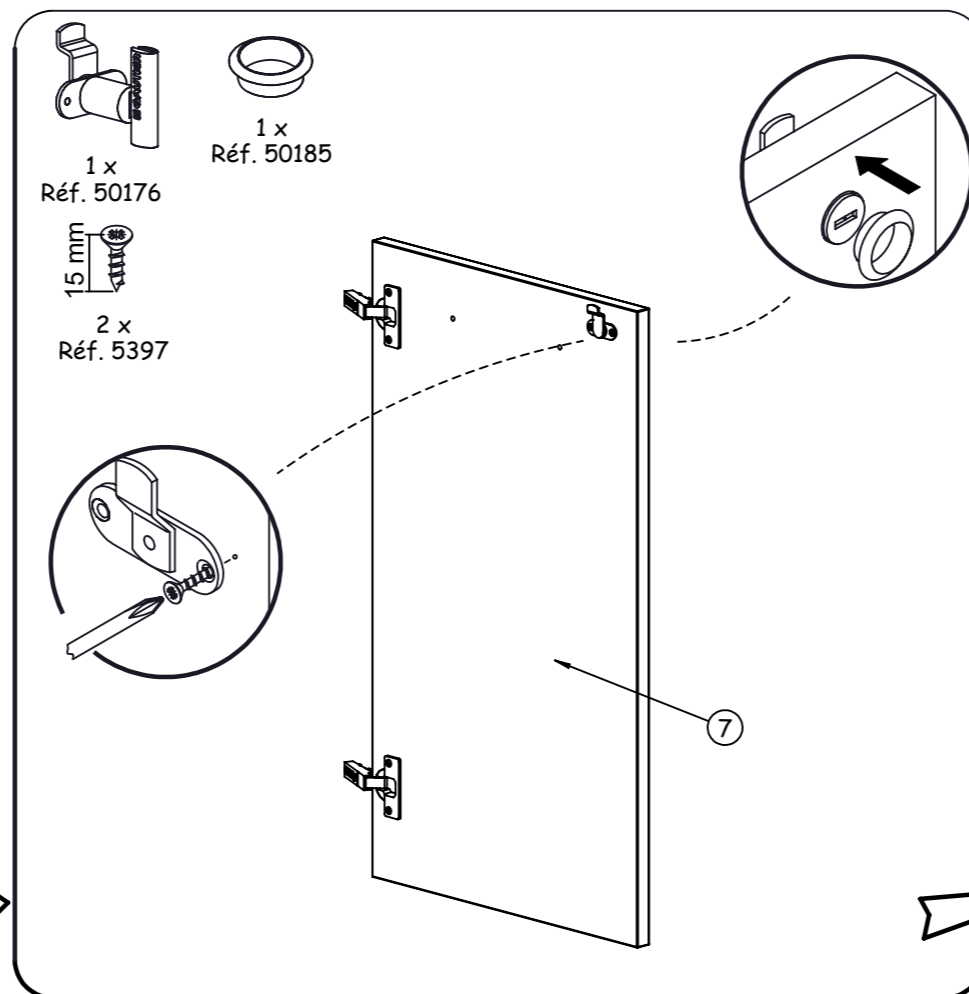
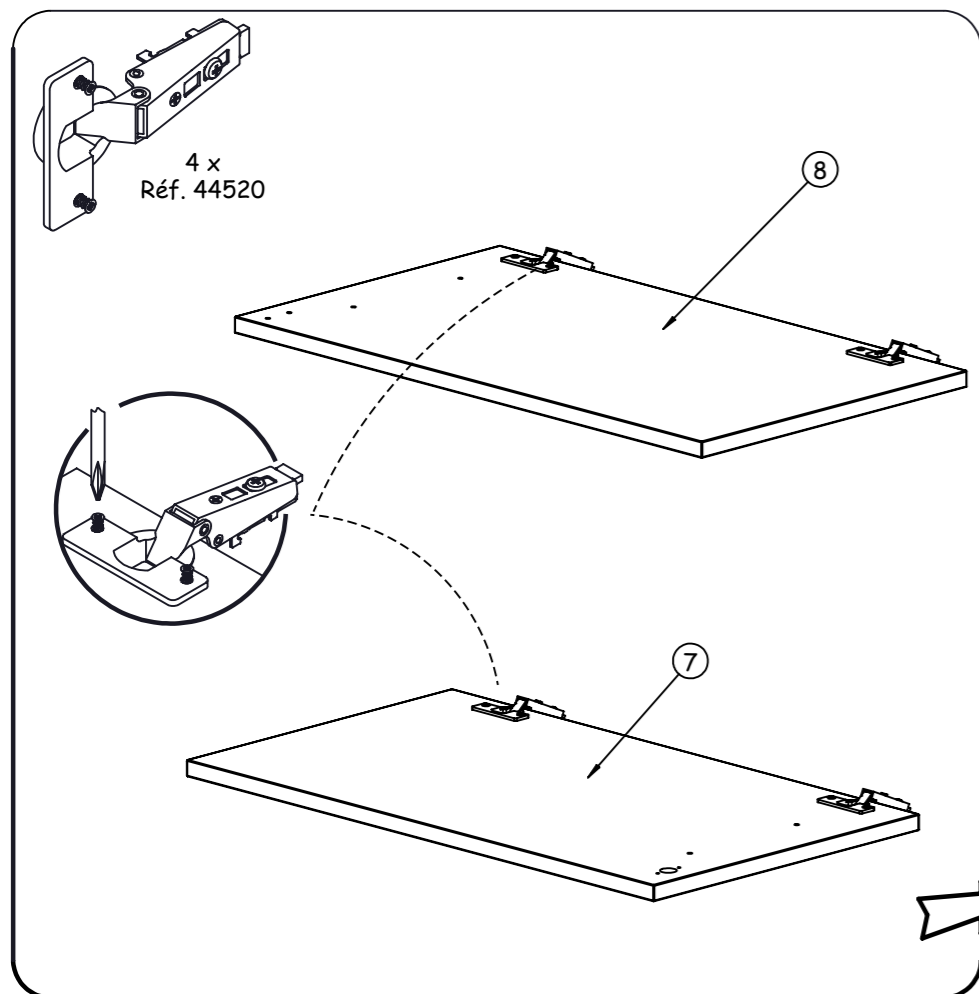
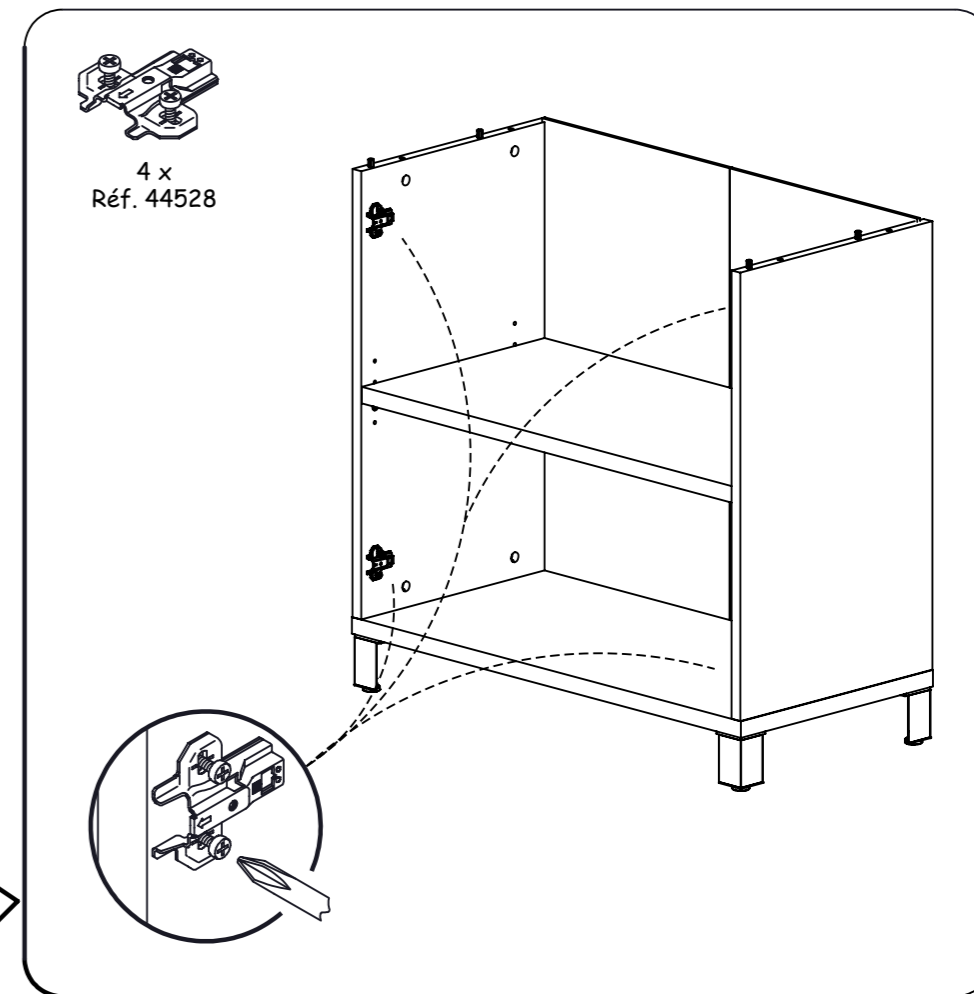
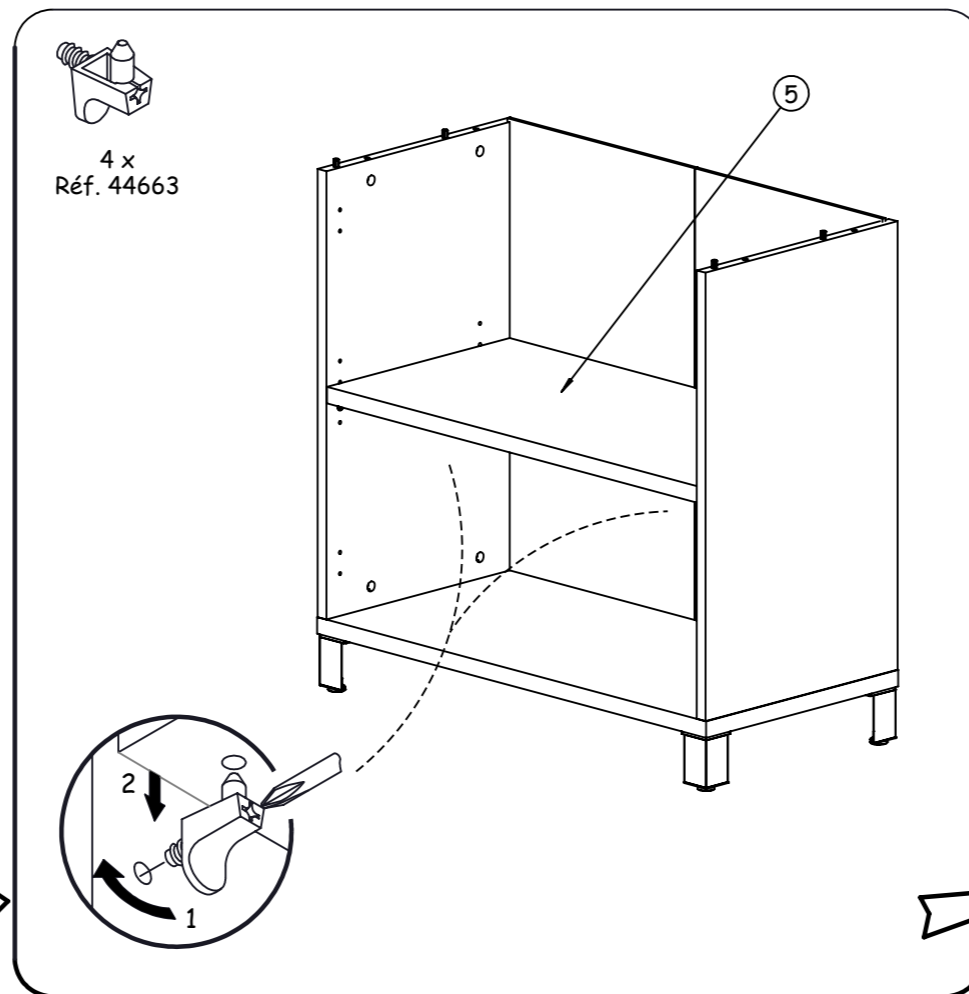
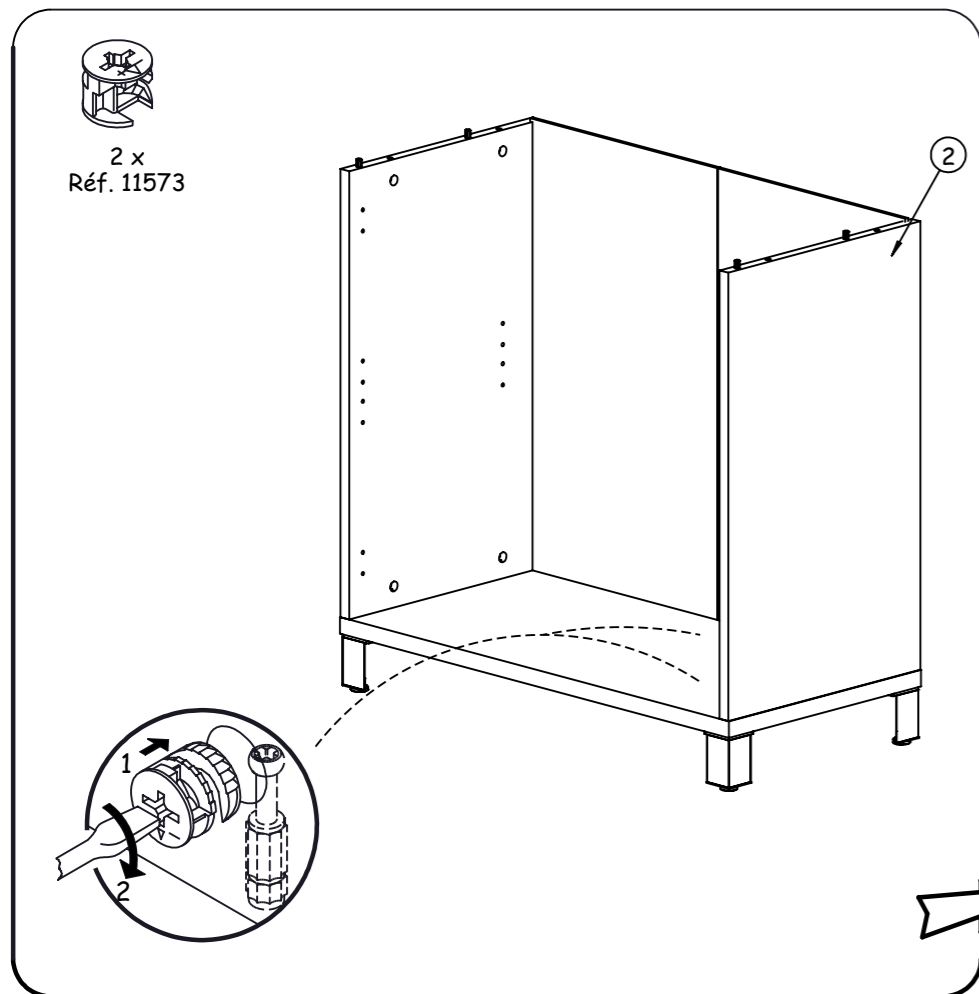

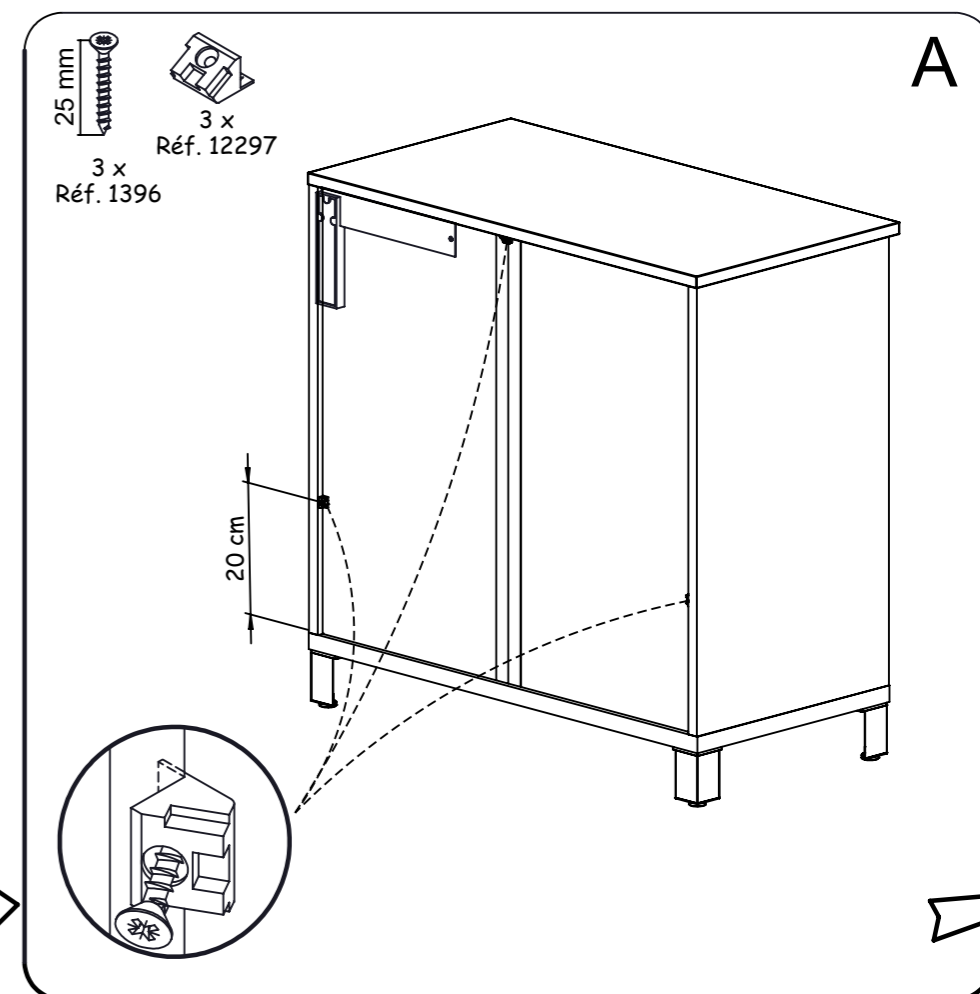
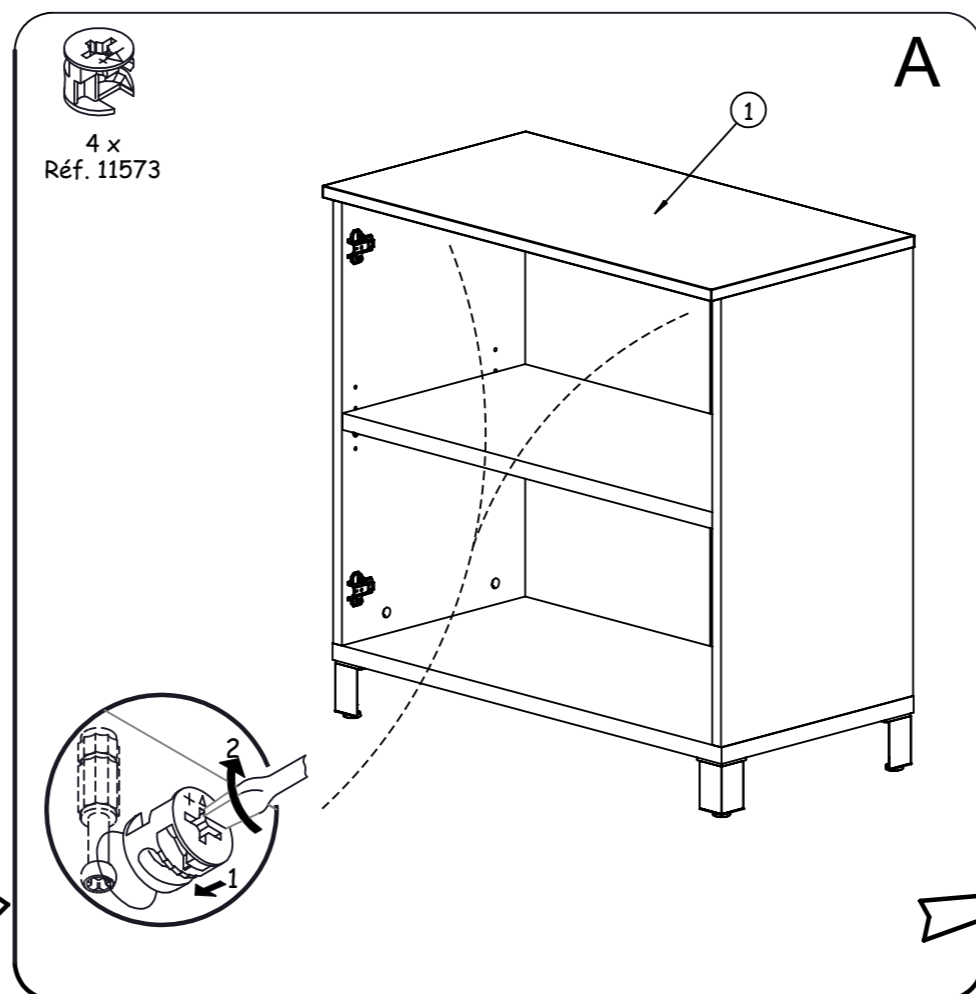
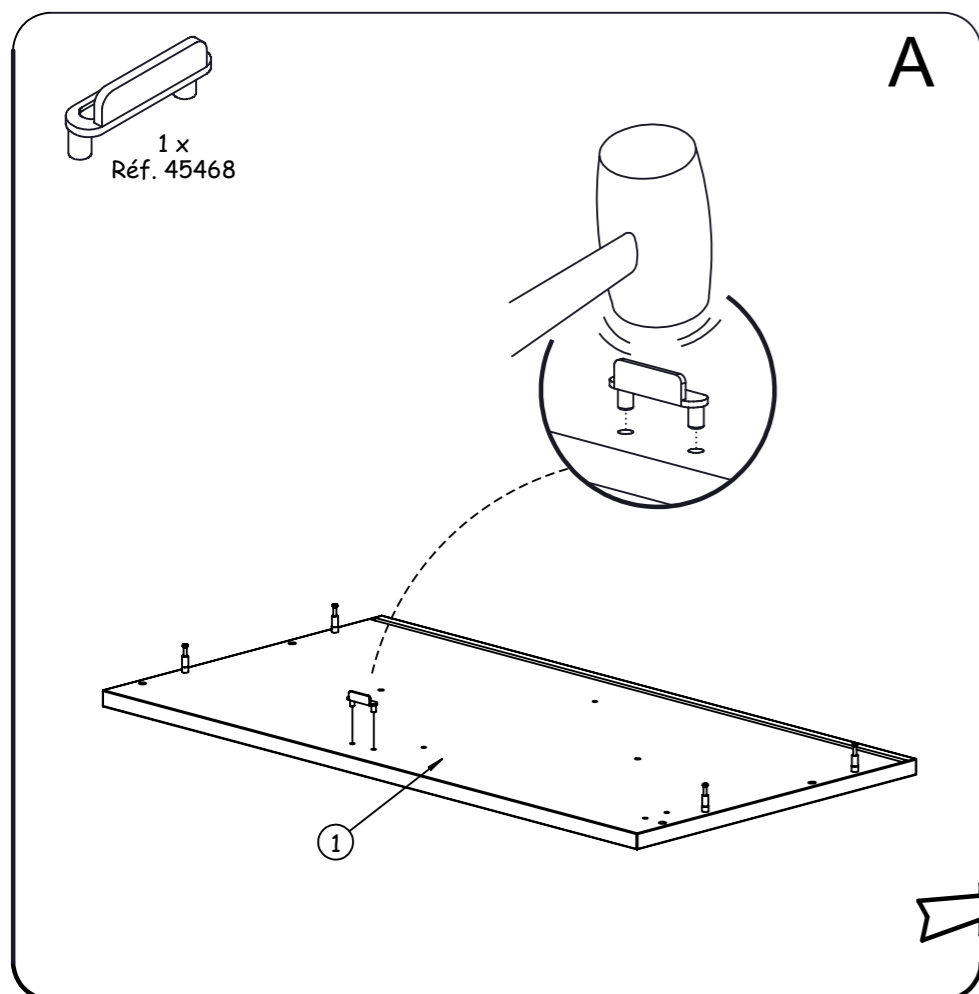
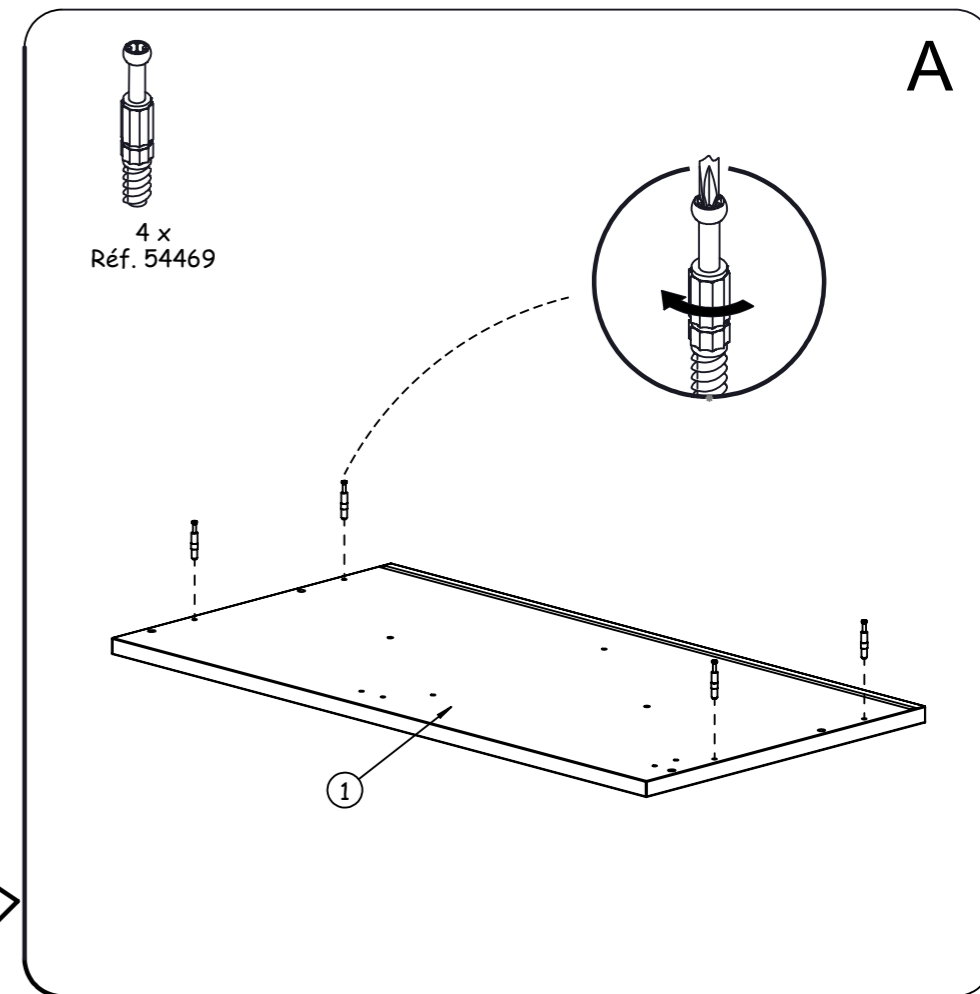
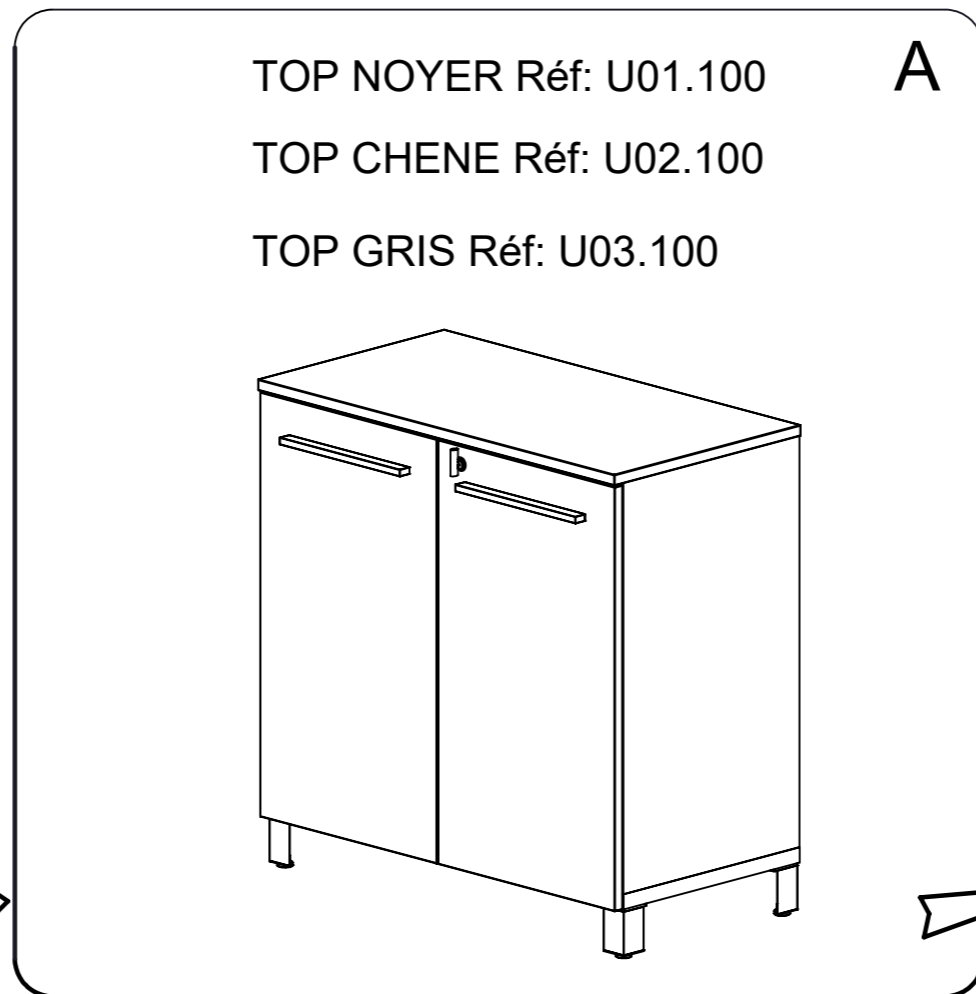
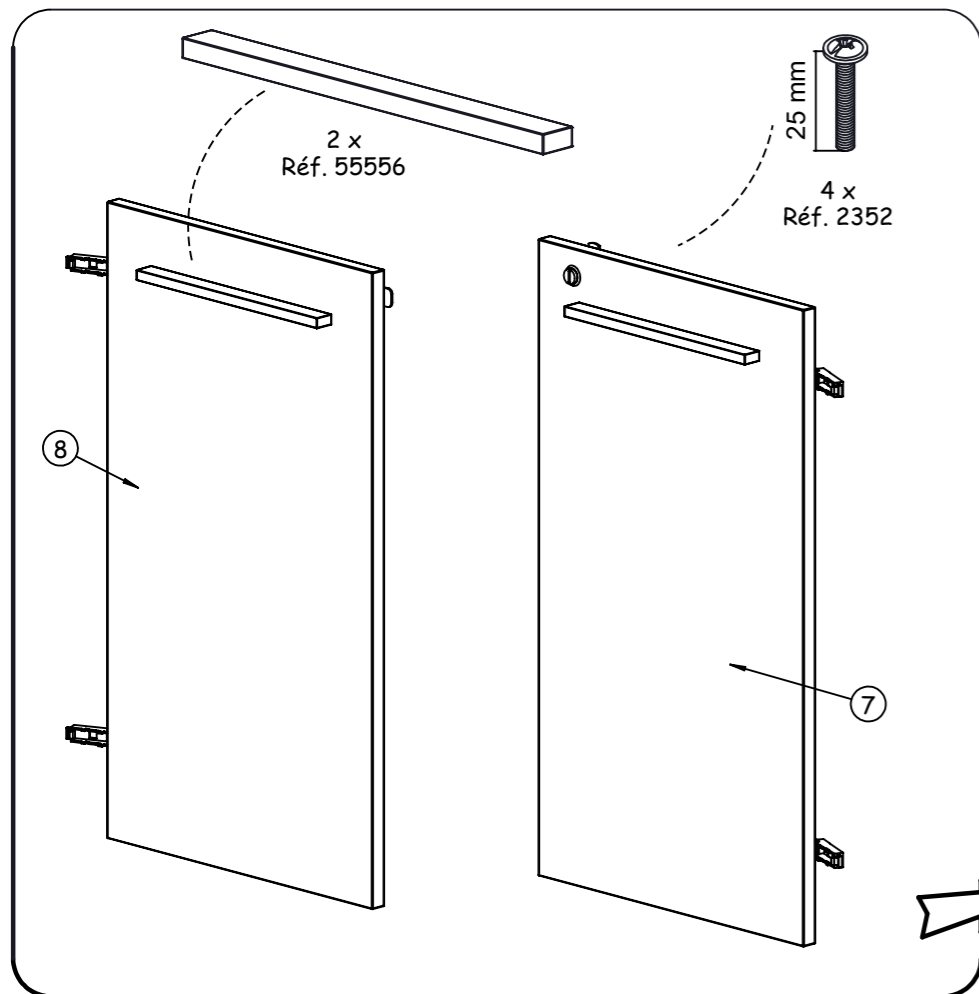

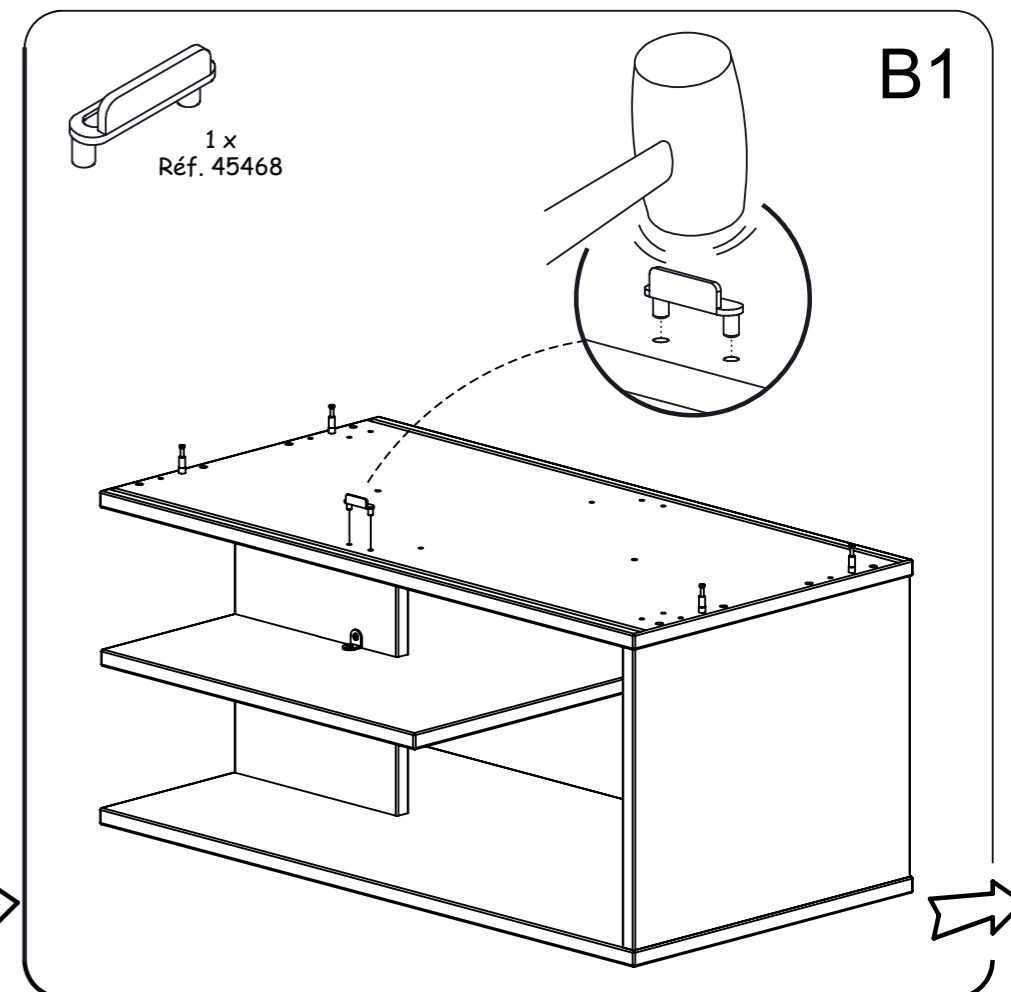
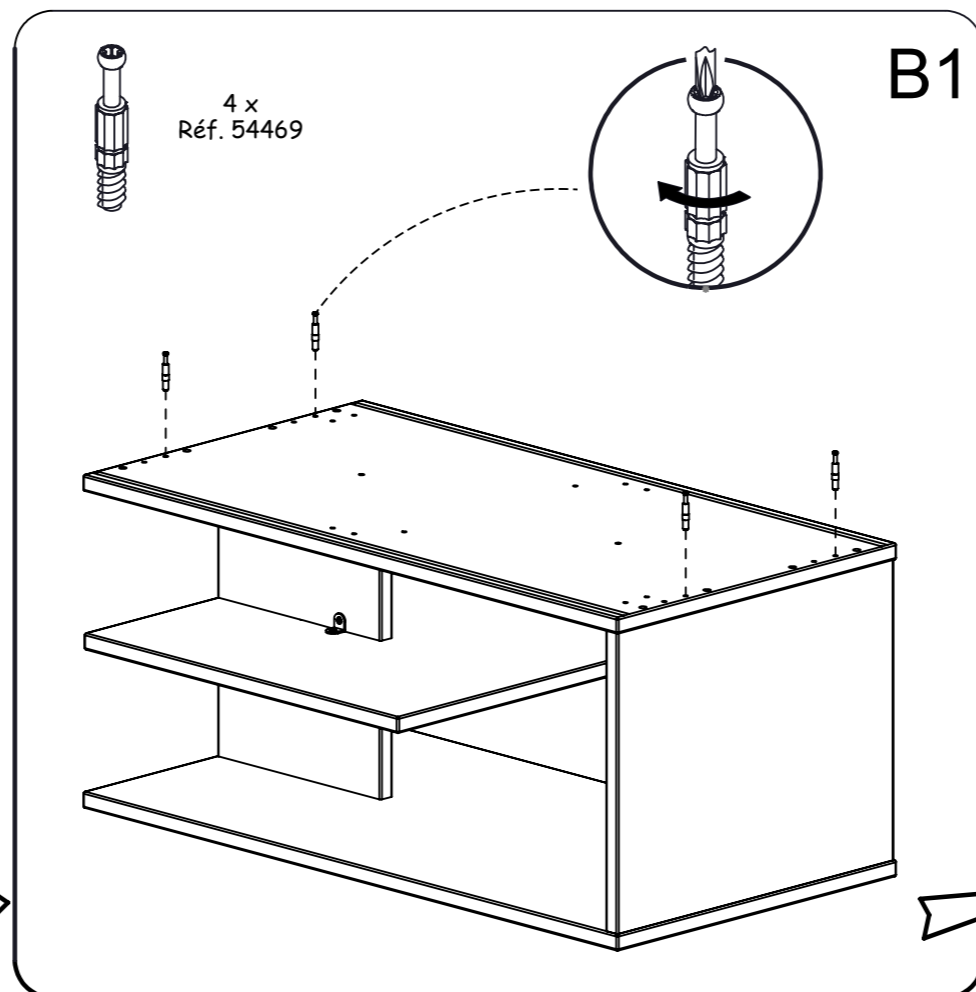
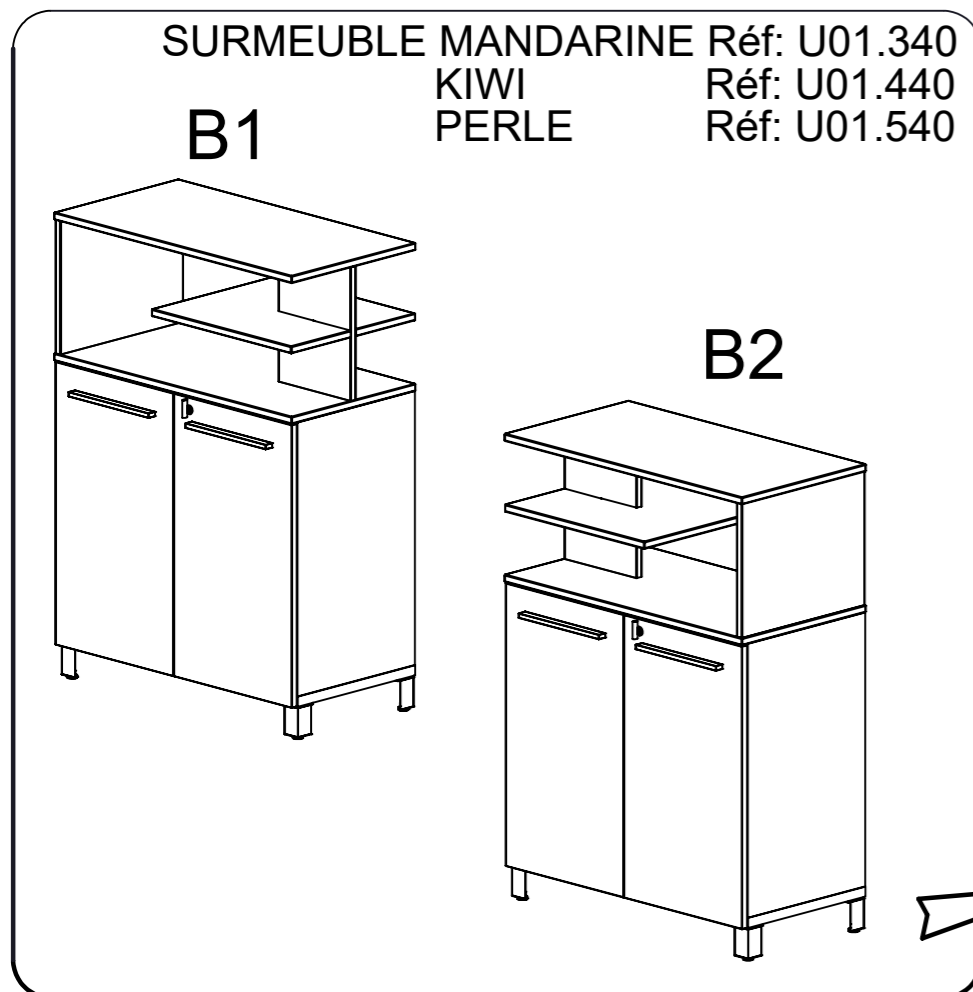
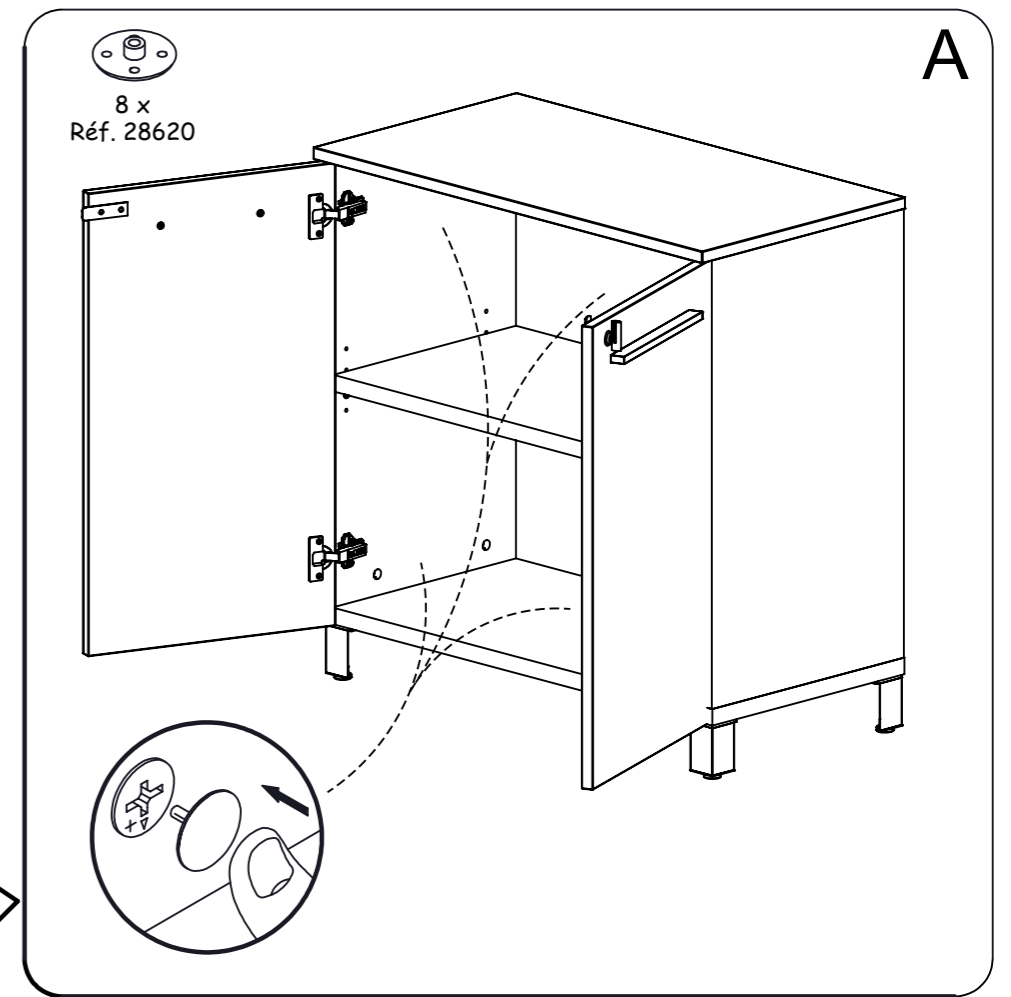
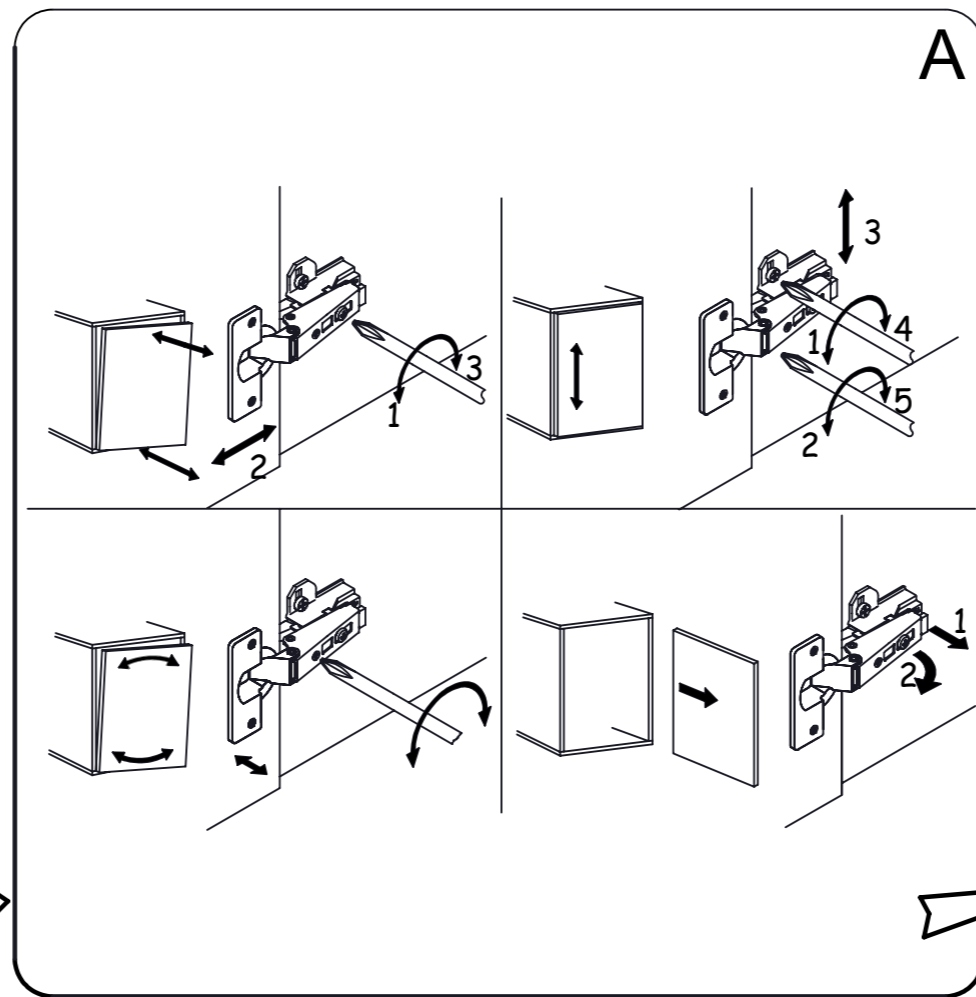
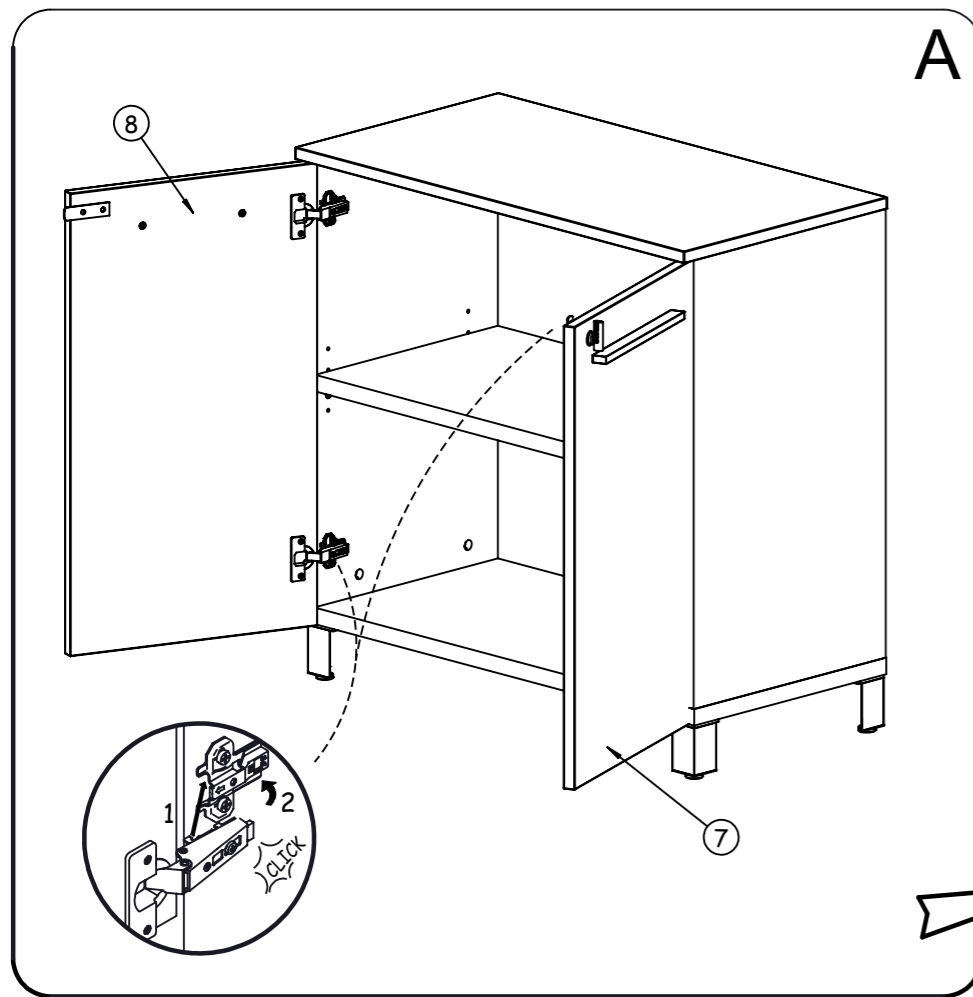

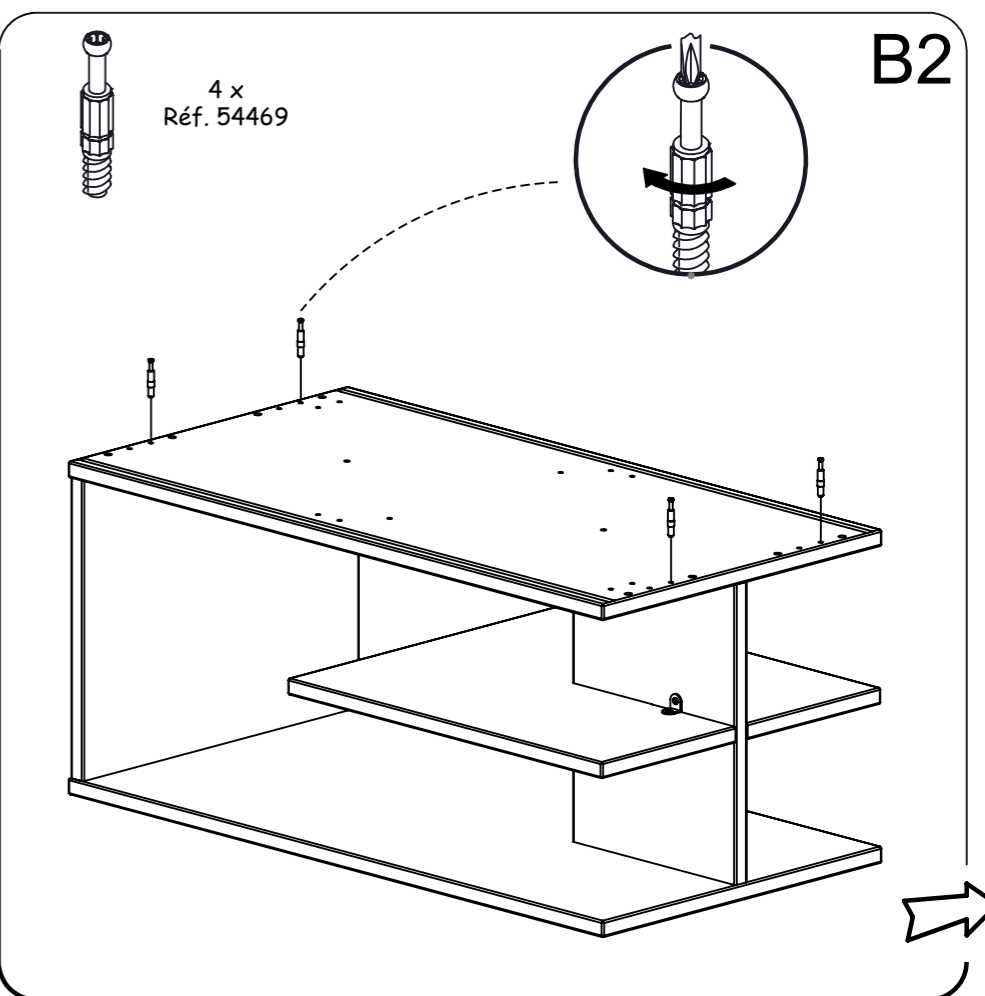
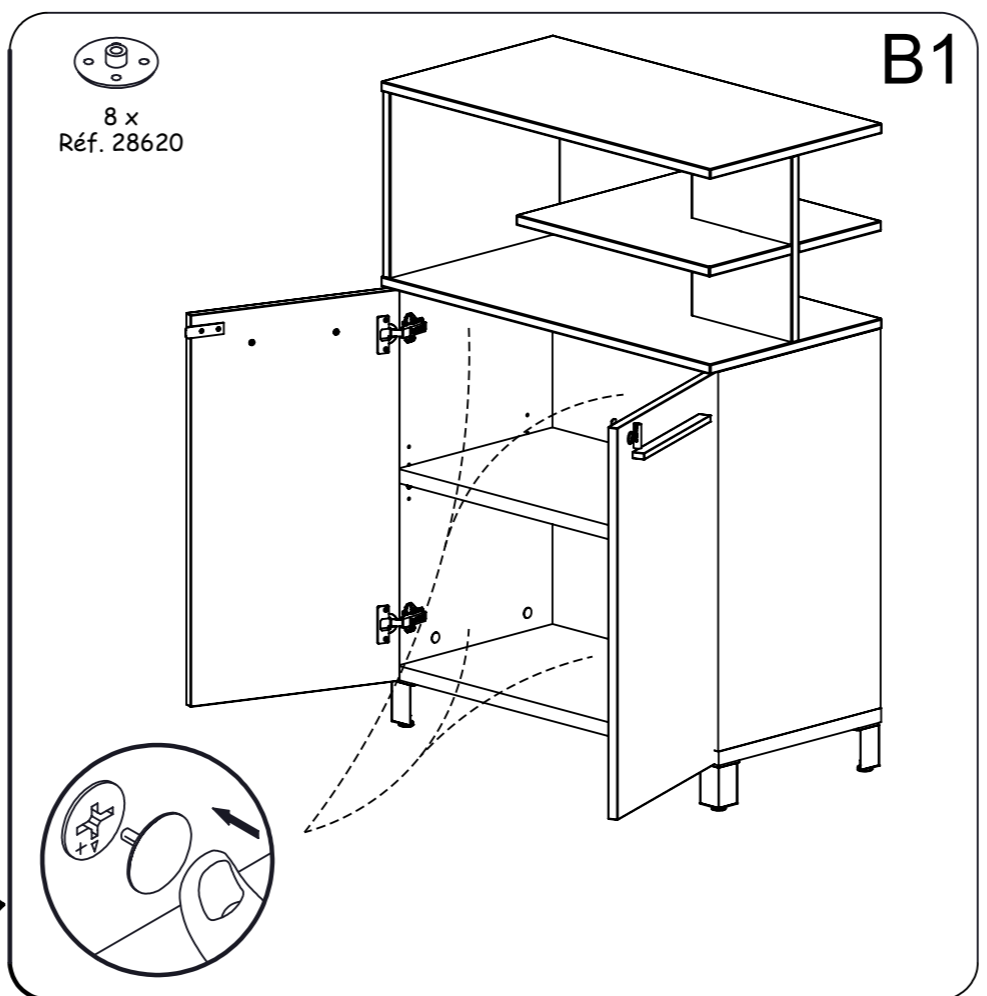
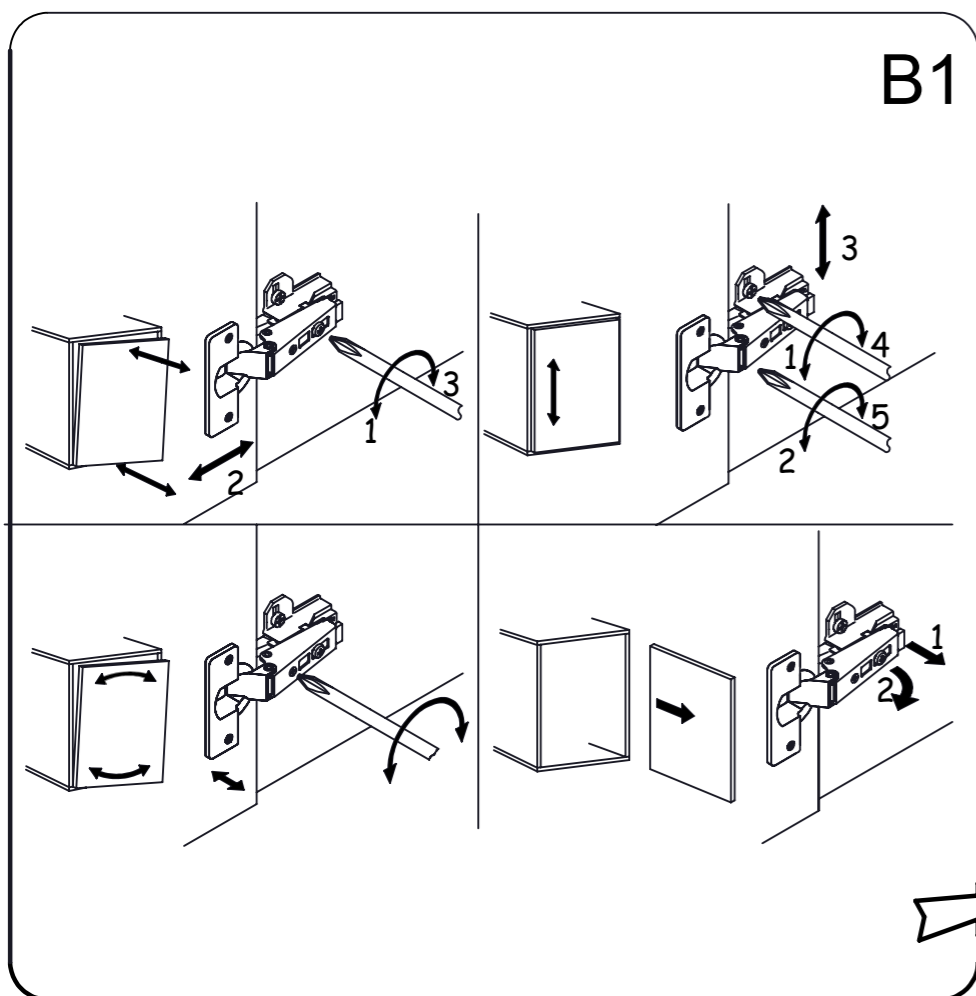
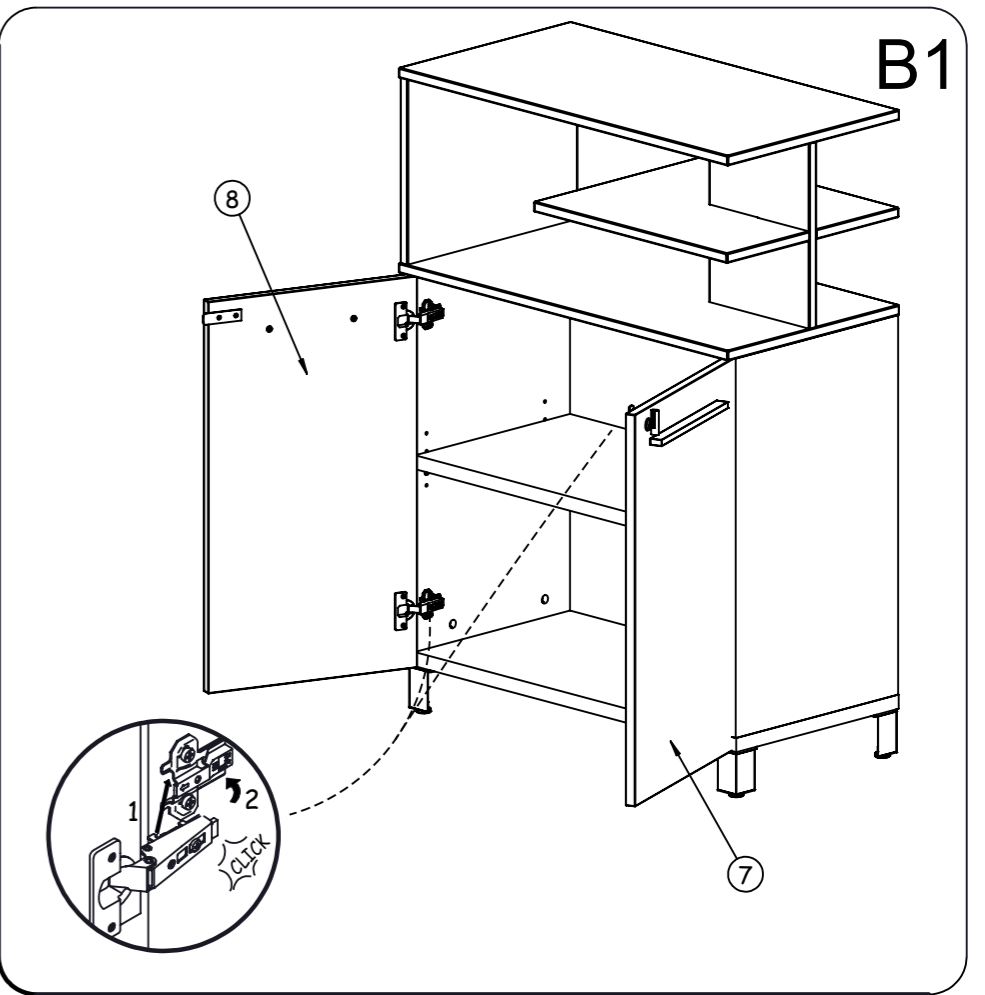
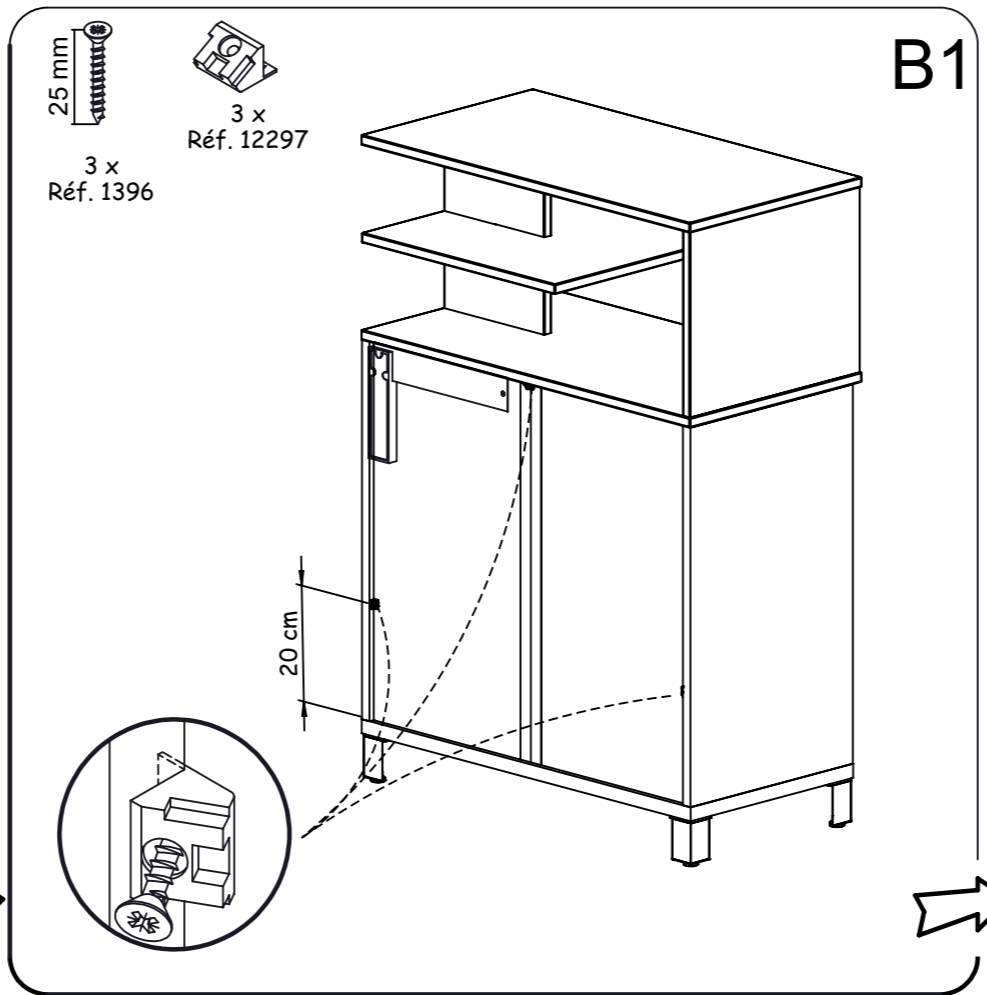
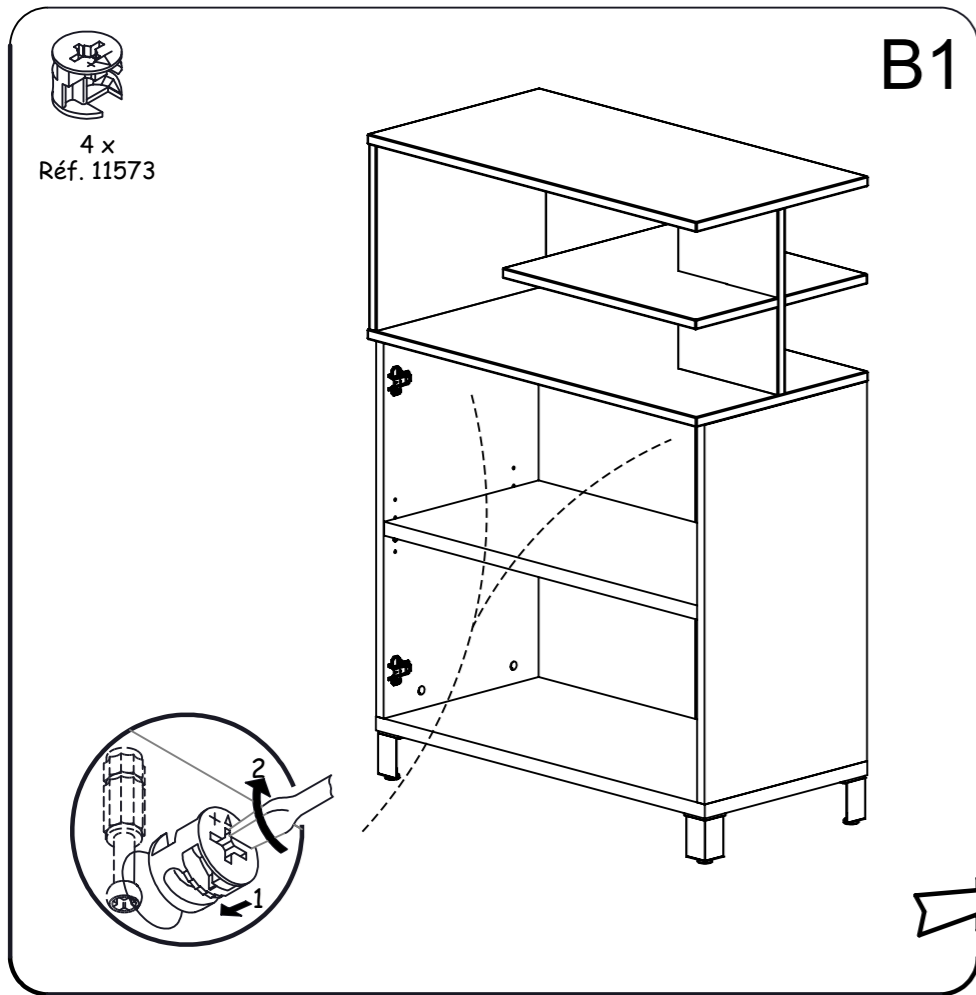

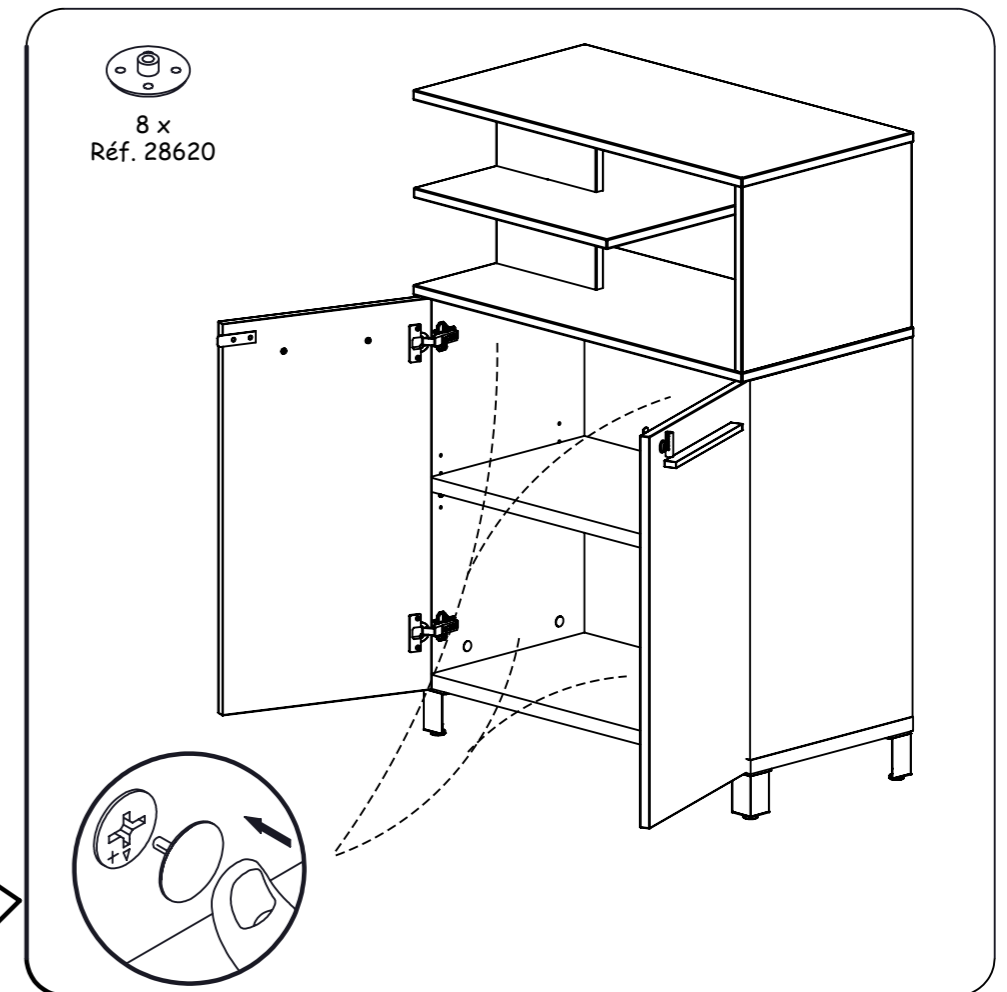
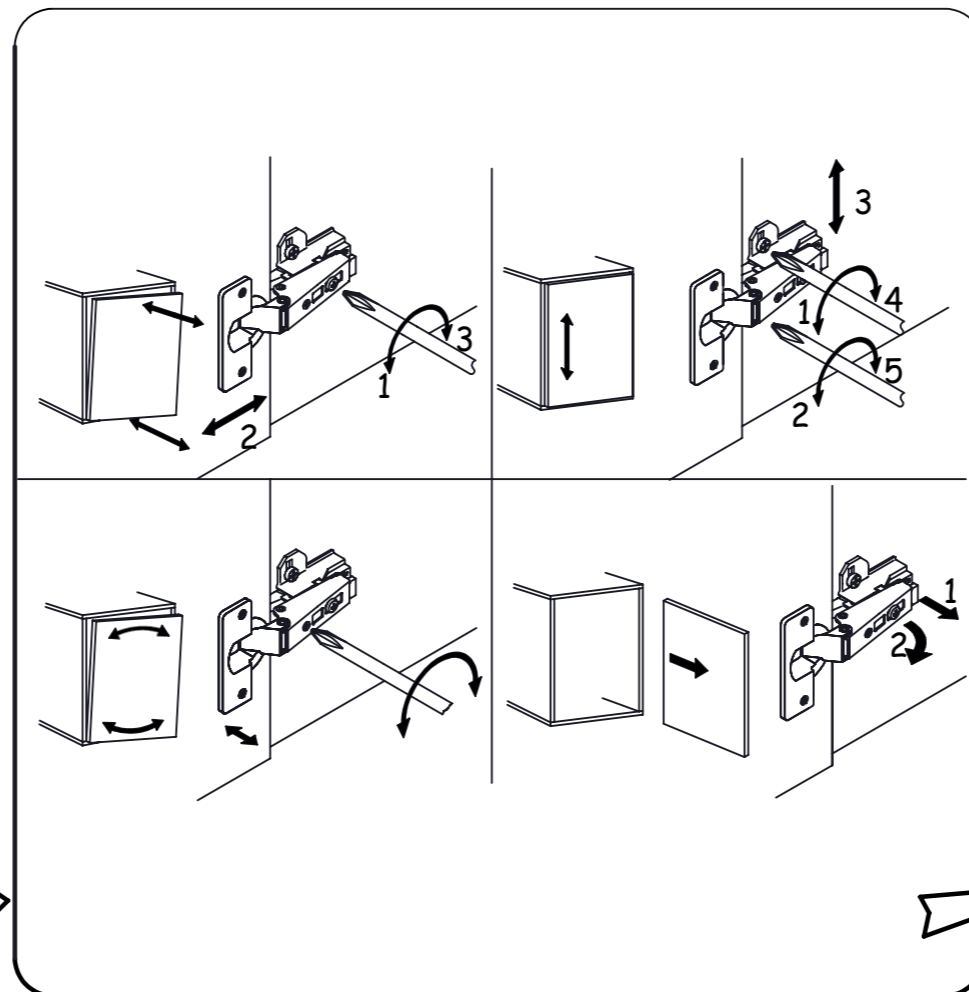
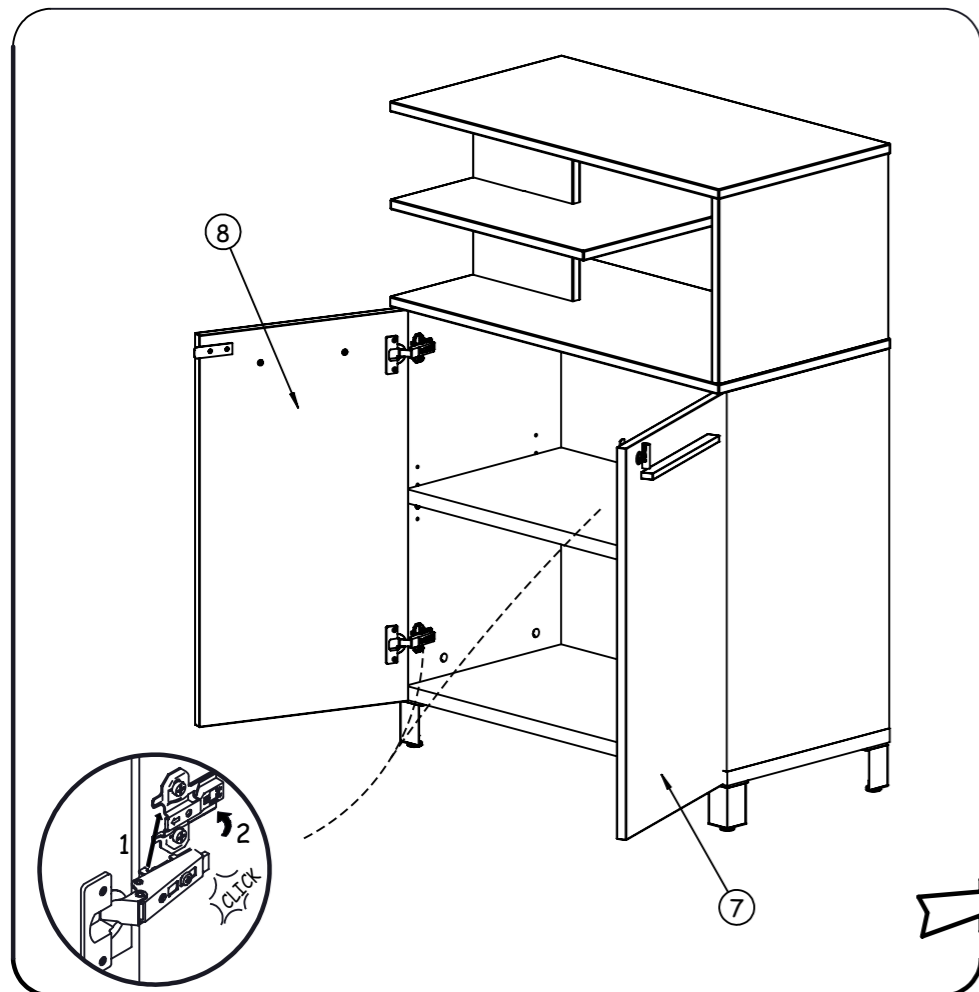
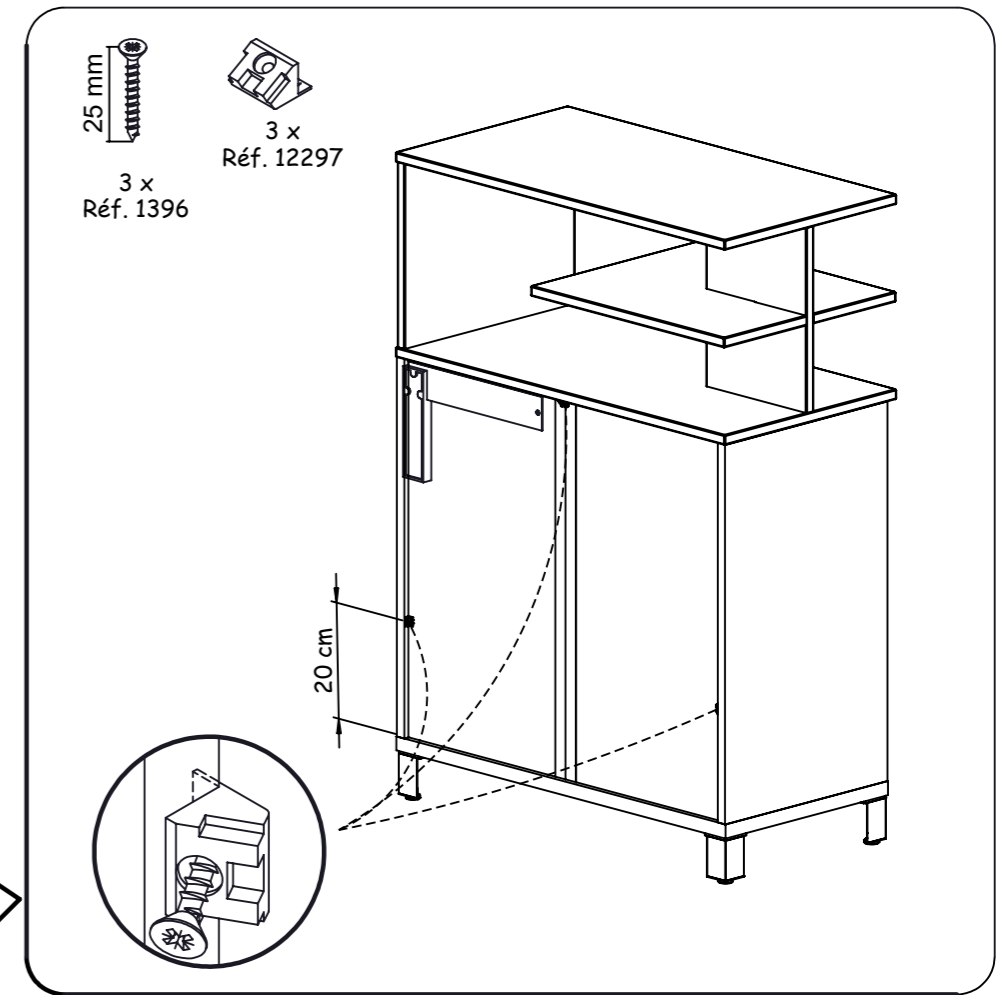
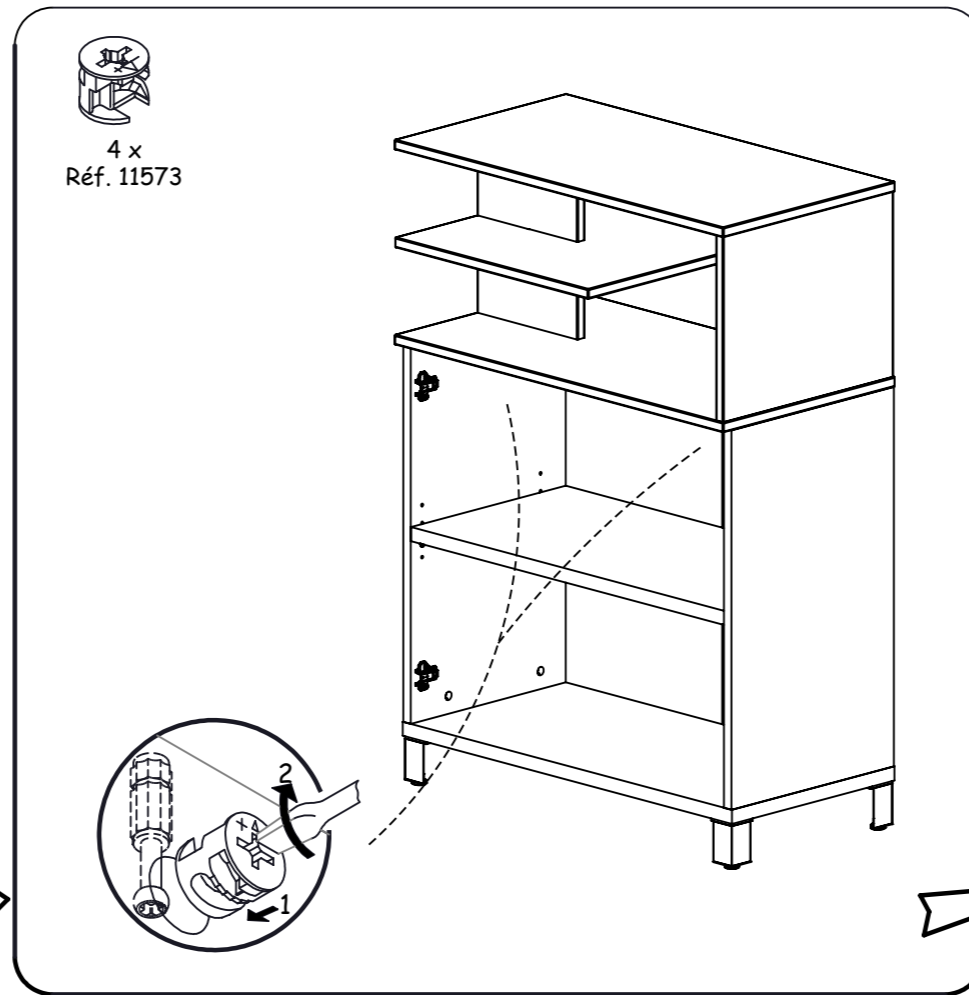
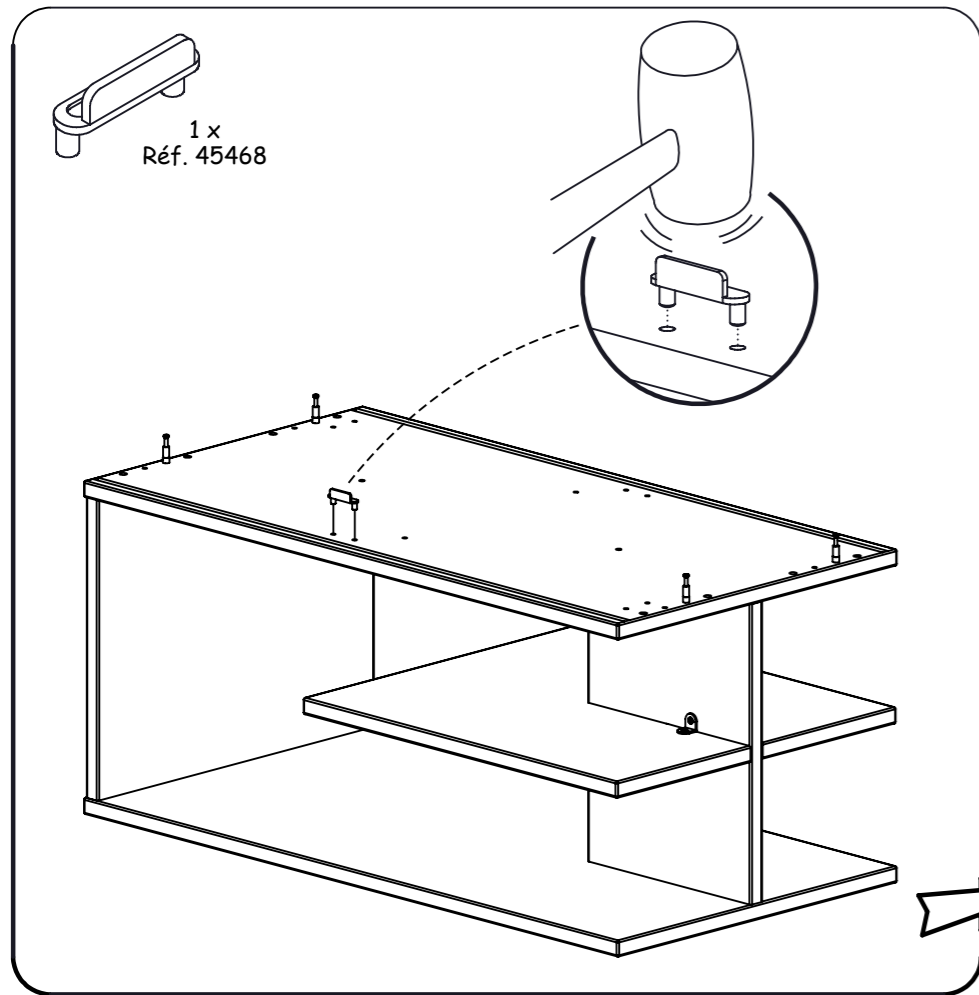

**INSTRUCTIONS DE RECYCLAGE - RECYCLING INSTRUCTIONS - INSTRUCCIONES DE RECICLAJE
 RECYCLING INSTRUCTIES - RECYCLING-ANWEISUNGEN - ISTRUZIONI DI RICICLAGGIO
 ИНСТРУКЦИЯ ПО УТИЛИЗАЦИИ - GERİ DÖNÜŞÜM TALİMATLARI**

FR Lors de l'élimination de votre mobilier usagé, les composants en bois, en plastique et en métal peuvent être séparés et être dirigés en déchetterie vers les contenants appropriés pour favoriser leur valorisation. Toutefois, si votre déchetterie est équipée d'une benne "meuble", vous pouvez déposer votre mobilier en l'état; l'éco-organisme gestionnaire de la filière DEA (www.eco-mobilier.fr) prendra en charge les opérations nécessaires à la valorisation optimale de celui-ci. Enfin n'oubliez pas que vous pouvez prolonger la durée de vie de vos produits usagés en contactant les associations caritatives de votre région.

GB When your furniture is no longer of use, its wood, plastic and metal components can be separated out and placed in the appropriate bins to be recycled. But remember that you may be able to extend the useful life of used furniture by passing it on to a charitable association in your neighbourhood.

ES Cuando elimine su mobiliario usado, los componentes de madera, plástico y metal pueden separarse y llevarse al vertedero y tirarse en los contenedores apropiados para su reciclaje. No obstante, no olvide que podrá prolongar la duración de vida de sus productos usados si se pone en contacto con las asociaciones de voluntariado social de su región.

NL Houten, plastic en metalen onderdelen van uw afgedankte meubels kunt u in gescheiden vorm aanbieden bij een afvalverzamelpunt en in de daarvoor bestemde containers werpen zodat ze opnieuw gebruikt kunnen worden. U kunt natuurlijk ook nog een tweede leven geven aan uw meubels door contact op te nemen met een liefdadigheidsinstelling bij u in de buurt.

DE Die Holz-, Kunststoff und Metallteile Ihrer Altmöbel können getrennt und in einem Wertstoffhof dem entsprechenden Recycling zugeführt werden. Ihre Altmöbel können jedoch auch für andere noch nützlich sein - wenden Sie sich an karitative Vereine in Ihrer Umgebung-Wohnregion.

IT Al momento dell'eliminazione del vostro mobile usato, i componenti in legno, in plastica ed in metallo possono essere separati ed essere portati in discarica verso i contenitori idonei per favorire la loro valorizzazione. Tuttavia, non dimenticate che potreste prolungare la durata di vita dei vostri prodotti usati contattando le associazioni caritative della vostra regione.

RU Для того, чтобы избавиться от старой мебели, можно рассортировать детали из дерева, пластика и металла и отправить в пункты сбора утиля для их переработки и вторичного использования. Однако, не забывайте, что вы можете продлить срок службы изделий, связавшись с благотворительными организациями вашего региона.

TR Eski mobilyanızı elden çıkarırken, ahşap, plastik ve metal bileşenler ayrıştırılabilir ve özel bir atık boşaltma yerinde tekrar değerlendirilmelerine katkıda bulunmak için uygun konteynlara bırakılabilir. Ancak unutmayınız ki bölgenizdeki hayır kurumlarıyla irtibata geçerek eskimiş ürünlerinizin ömrünü uzatabilirsiniz.

Merci de garder ce document pendant toute la vie du produit. vous pouvez le coller comme indiqué ci-contre.
Please conserve this document all along the product life. You can stick it as noticed on the picture.

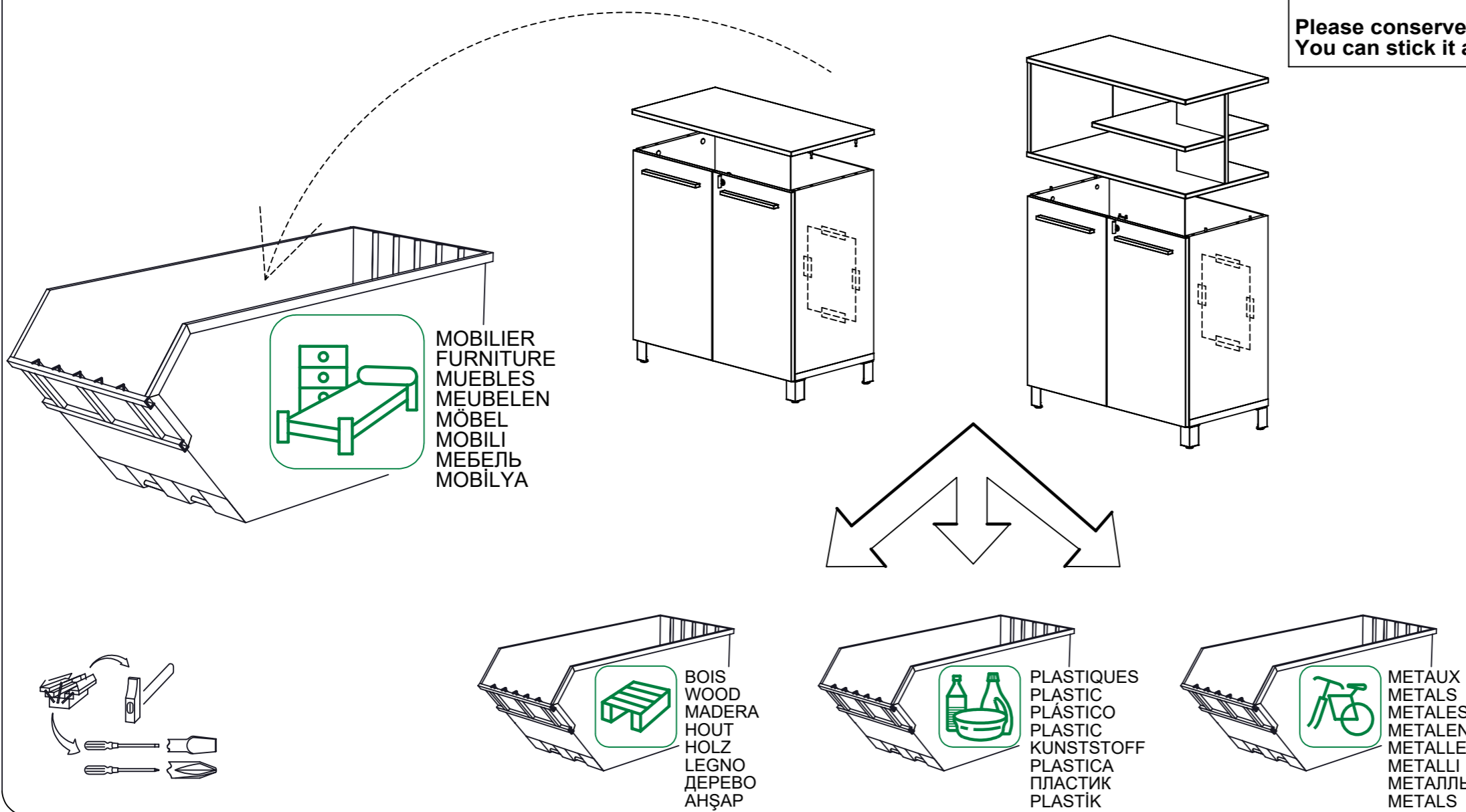

CONSEILS D'ENTRETIEN :

MELAMINES, LAQUES ET VERNIS SE NETTOIENT EXCLUSIVEMENT A L'AIDE D'EAU SAVONNEUSE.

HINTS ON CARE :

MELAMINE, ENAMELS AND VARNISHES ARE EXCLUSIVELY CLEANED WITH SUDSY WATER.

CONSEJOS PARA EL CUIDADO :

MELAMINA, LACADOS Y BARNIZADOS SE LIMPIAN EXCLUSIVAMENTE CON AGUA ENJABONADA.

ONDERHOUD :

VOOR LAK EN VERNIS ALLEEN MAAR EEN LICHT SOP GEBRUIKEN.

PFLEGEVORSCHRIFTEN :

MELAMINBESCHICHTUNGEN, LACKE UND FIRNISSE SIND NUR MITTELS SEIFENWASSER ZU REINIGEN.

MANUTENZIONE :

MELAMINATO, LACCHE E VERNICI SI PULISCONO ESCLUSIVAMENTE E SOLO CON ACQUA E SAPONE.

СОВЕТЫ ПО УХОДУ ЗА МЕБЕЛЬЮ:

ПОКРЫТИЯ ИЗ МЕЛАМИНА, ЭМАЛИ ИЛИ ЛАКА МОЖНО ЧИСТИТЬ ТОЛЬКО МЫЛЬНОЙ ВОДОЙ.

GARANTIE :

SI VOUS CONSTATEZ UNE EVENTUELLE ANOMALIE, PRECISEZ LA NATURE DU DEFAUT SUR CETTE FICHE ET RETOURNEZ-LA AU MAGASIN QUI VOUS A VENDU LE MEUBLE. CE DOCUMENT NOUS SERA IMMEDIATEMENT TRANSMIS SI UNE PIECE EST DETERIOREE EN COURS D'UTILISATION, VOUS POUVEZ NOUS LA COMMANDER JUSQU'A 5 ANS APRES VOTRE DATE D'ACHAT.

GARANTY :

IN THE UNLIKELY EVENT OF THERE BEING A MANUFACTURING OR MATERIAL DEFECT, PLEASE CONTACT THE RETAILER FROM WHOM YOU PURCHASED OUR FURNITURE WITHOUT DELAY. STEPS WILL THEN BE TAKEN TO EFFECT EARLY REMEDIAL ACTION.

IF A PART IS DAMAGED IN USE, YOU CAN ORDER IT UP TO 5 YEARS AFTER YOUR DATE OF PURCHASE

GARANTIA :

SI USTED OBSERVA ALGUNA EVENTUAL ANOMALIA, EXPLIQUE LA NATURALEZA DEL DEFECTO Y DEVUELVA LA FICHA A LA TIENDA DONDE HA COMPRADO EL MUEBLE, QUE NOS LO HARA SEGUIR.

I UNA PIEZA SE DETERIORA EN USO, USTED PUEDE PEDIRNOS ESA PIEZA HASTA UN PLAZO DE 5 AÑOS DESPUÉS DE SU FECHA DE COMPRA

WAARBORG :

GELIEVE DE BIJHORENDE GARANTIEKAART MET EVENTUELE AARD EN OORZAAK VAN BESCHADIGINGEN NAAR UW WINKELIER TERUG TE STUREN, DIE ZE ONS ZAL DOORSUREN.

IN GEVAL EEN ONDERDEEL GEDURENDE HET GEBRUIK BESCHADIGD WORDT KAN U DIT TOT 5 JAAR NA UW AANKOOPDATUM BESTELLEN.

GARANTIE :

SOLLTEN SIE EVENTUELL EINEN MANGEL FESTSTELLEN SO BITTEN WIR SIE, UNS DIESEN NACHSTEHEND ZU BESCHREIBEN UND DIESES BLATT IHREM LIEFERANTEN ZUZUSENDEN.

SOLLTEN TEILE ENTSPRECHENDE ABNÜTZUNG ODER GEBRAUCHSPUREN AUFWEISEN, KÖNNEN SIE DIESES SPÄTESTENS INNERT 5 JAHREN NACH KAUFDATUM-VERTRAGSABSCHLUSS NACHBESTELLEN.

GARANZIA :

SE, NONOSTANTE TUTTI I NOSTRI CONTROLLI, CONSTATATE UN'ANOMALIA SU QUESTO MOBILE, VI PREGHIAMO CORTESEMENTE DI PRECISARE LA SUA NATURA SUL QUESTIONARIO DELL'ULTIMA PAGINA DI QUESTA GUIDA E DI CONSEGNARE QUESTO DOCUMENTO AL VOSTRO DISTRIBUTORE CHE CE LO TRASMETTERÀ.

SE DEI PEZZI IN BASE ALL'UTILIZZO SI FOSSERO DANNEGGIATI OPPURE DETERIORATI È POSSIBILE RIORDINARE I RISPETTIVI RICAMBI ENTRO 5 ANNI DALLA DATA DI ACQUISTO-CONTRATTUALE

ГАРАНТИЯ :

Если вы вдруг обнаружили дефекты материала или производства, точно опишите дефект на этом листе и обратитесь в магазин, в котором вы купили мебель. этот документ будет немедленно нам передан и нами рассмотрен.

Если одна из деталей пришла в негодность во время эксплуатации изделия, то вы можете её заказать у нас в течение 5 лет со дня покупки.

NOM / NAME: **ADRESSE / ADDRESS:**

.....

NATURE DU DEFAUT EVENTUEL / NATURE OF THE DEFECT IF ANY :

.....

**ORDRE DE DEBALLAGE DES COLIS
UNPACKING ORDER OF THE PARCELS
DESEMBALAR LOS BULTOS EN ESTE ORDEN
VOLGORDE VAN UITPAKKEN VAN DE KOLLIS
REIHENFOLGE BETREFFEND DAS AUSPACKEN DER KOLLIS
RISPETTARE L'ORDINE CRONOLOGICO PER L'APERTURA DEI PACCHI.
ПОРЯДОК РАСПАКОВКИ ДЕТАЛЕЙ**

NUMERO DE CONTROLE / CONTROL NUMBER :

(MERCİ DE COCHER, SUR CETTE FICHE, LE NUMERO DE PIECE ET LA REFERENCE COLIS FAISANT OBJET DE LA RECLAMATION)
(PLEASE CROSS ON THIS FITTING INSTRUCTION THE PIECE NUMBER AND THE PACK REFERENCE CORRESPONDING TO THE PIECE DAMAGED)

COLIS 1

(REF.U01.211)

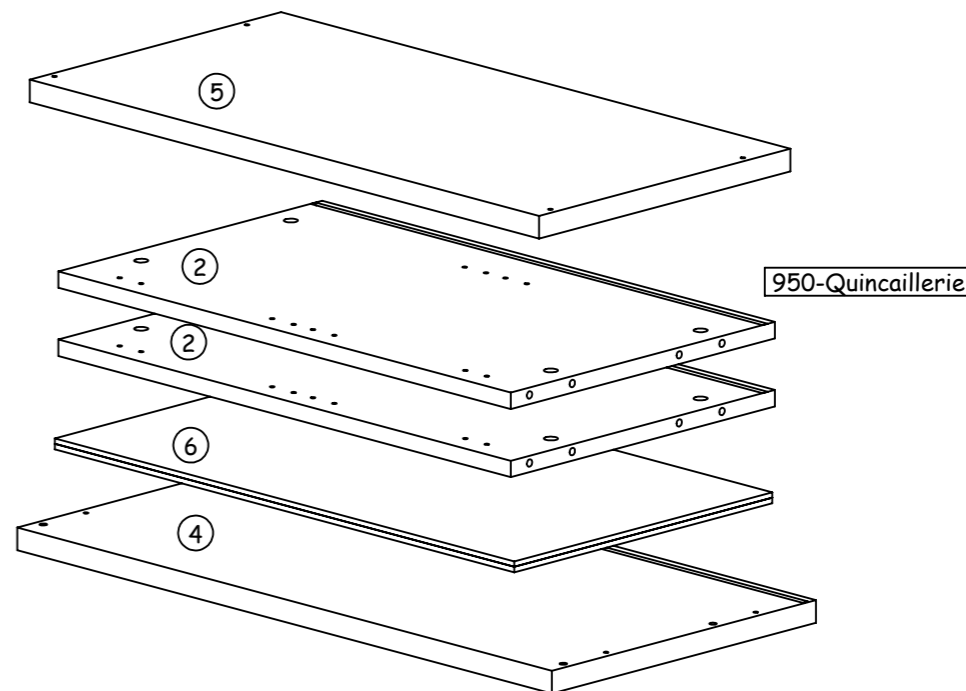

COLIS 2

(REF.U01.212)

(REF.U02.212)

(REF.U03.212)

