

GAUTIER office

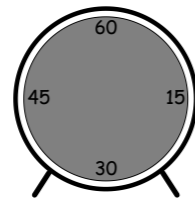

- FR - IMPORTANT - A lire soigneusement - A conserver pour consultation ultérieure
- GB - IMPORTANT - Read carefully and keep for information later
- ES - IMPORTANTE - Leer atentamente y guardar para consultas posteriores
- NL - BELANGRIJK, Lees deze instructies aandachtig en bewaar ze zodat u ze later nog kunt raadplegen
- DE - WICHTIGER HINWEIS. Bitte lesen sie diese unterlagen aufmerksam durch und bewahren sie sie auf
- IT - IMPORTANTE - Da leggere attentamente e da conservare per una ulteriore consultazione.
- RU - Это важно! Внимательно прочитайте данную инструкцию и сохраните ее для того, чтобы в дальнейшем при необходимости к ней обращаться.
- TR - ÖNEMLI, Dikkatli şekilde okuyunuz ve daha sonra başvurmak üzere saklayınız.

U01 - SUNDAY Noyer
 U02 - SUNDAY Chêne
 U03 - SUNDAY Gris

BANQUE DROITE 80
 REF. 028

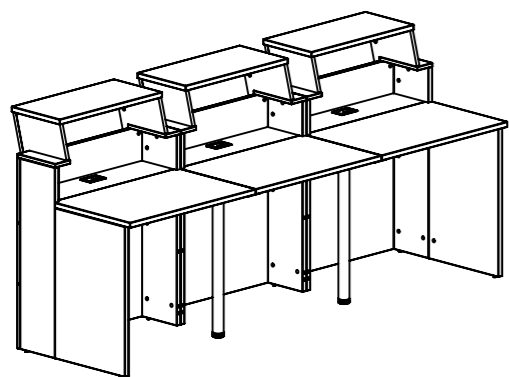
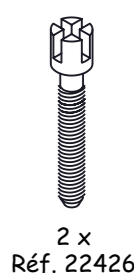
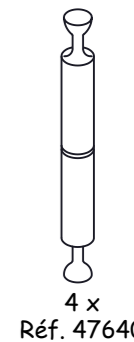
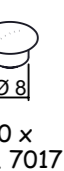
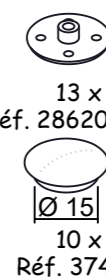
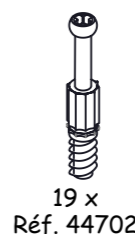
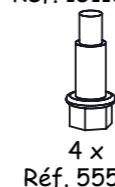
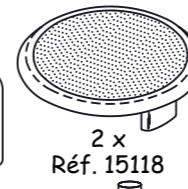
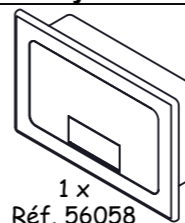
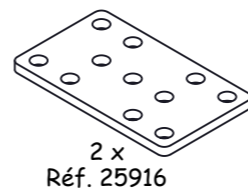
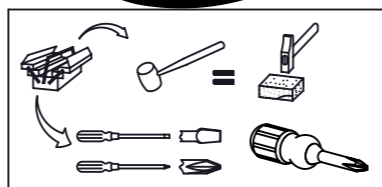
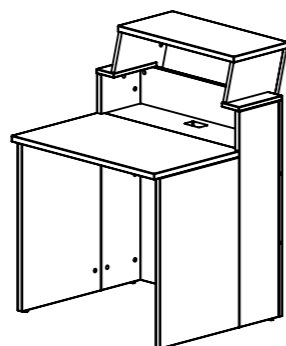

VOIR PAGE 6 AVANT DE
 COMMENCER LE MONTAGE

SEE PAGE 6 BEFORE OF
 BEGIN THE ASSEMBLY

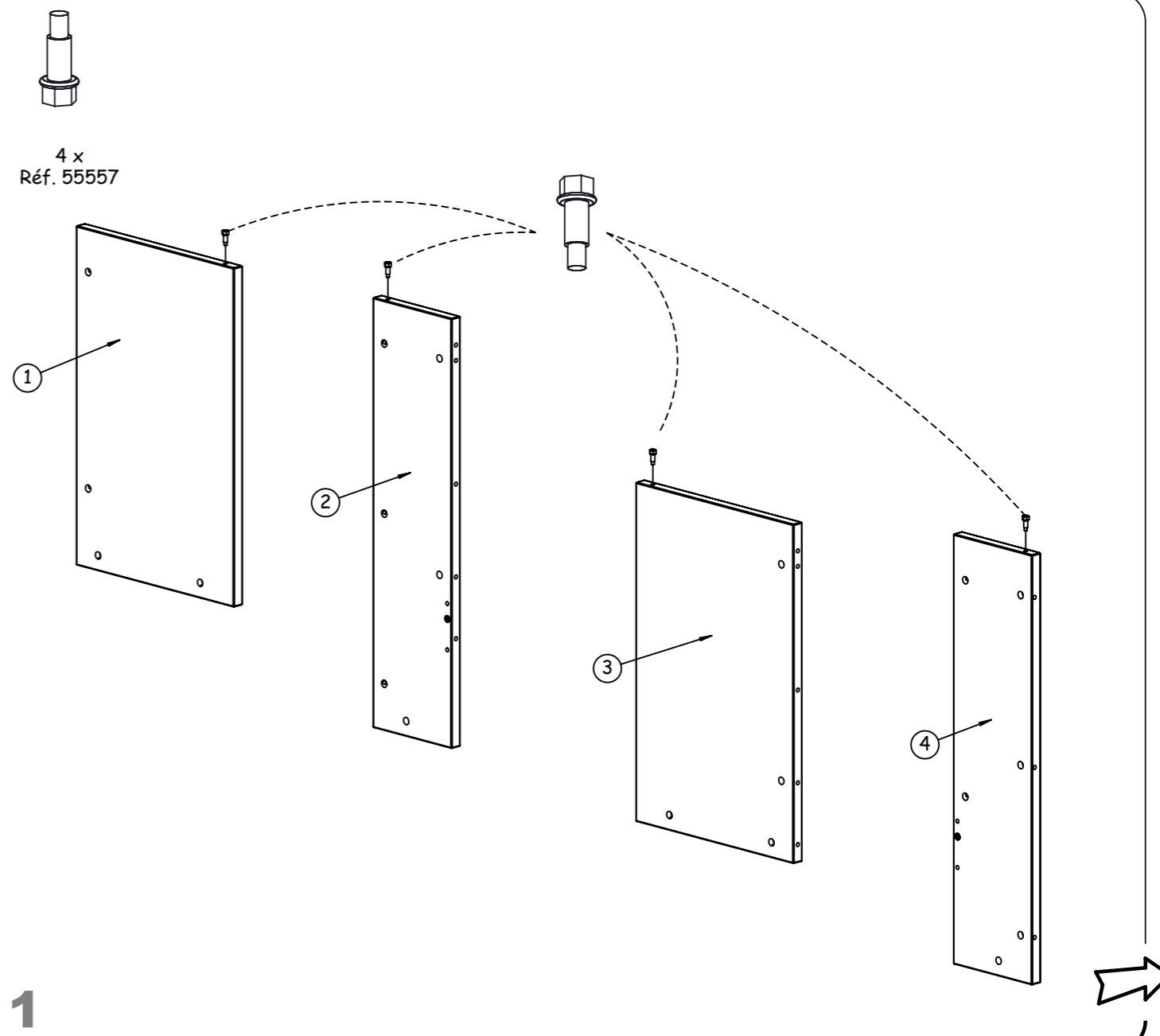
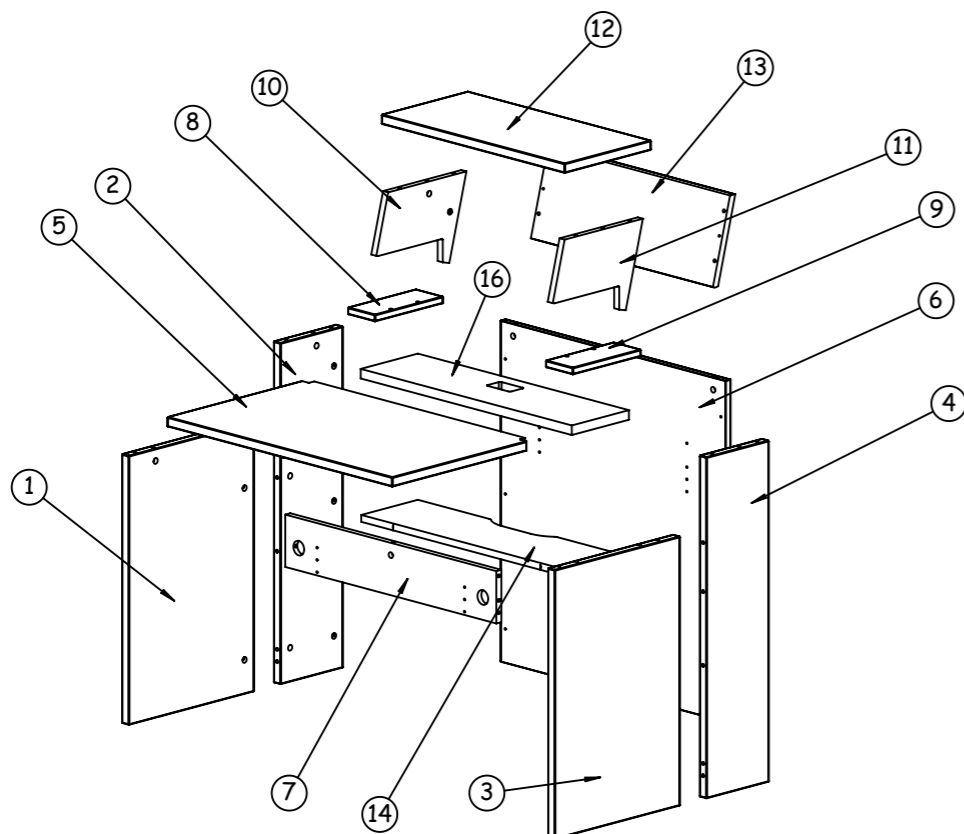

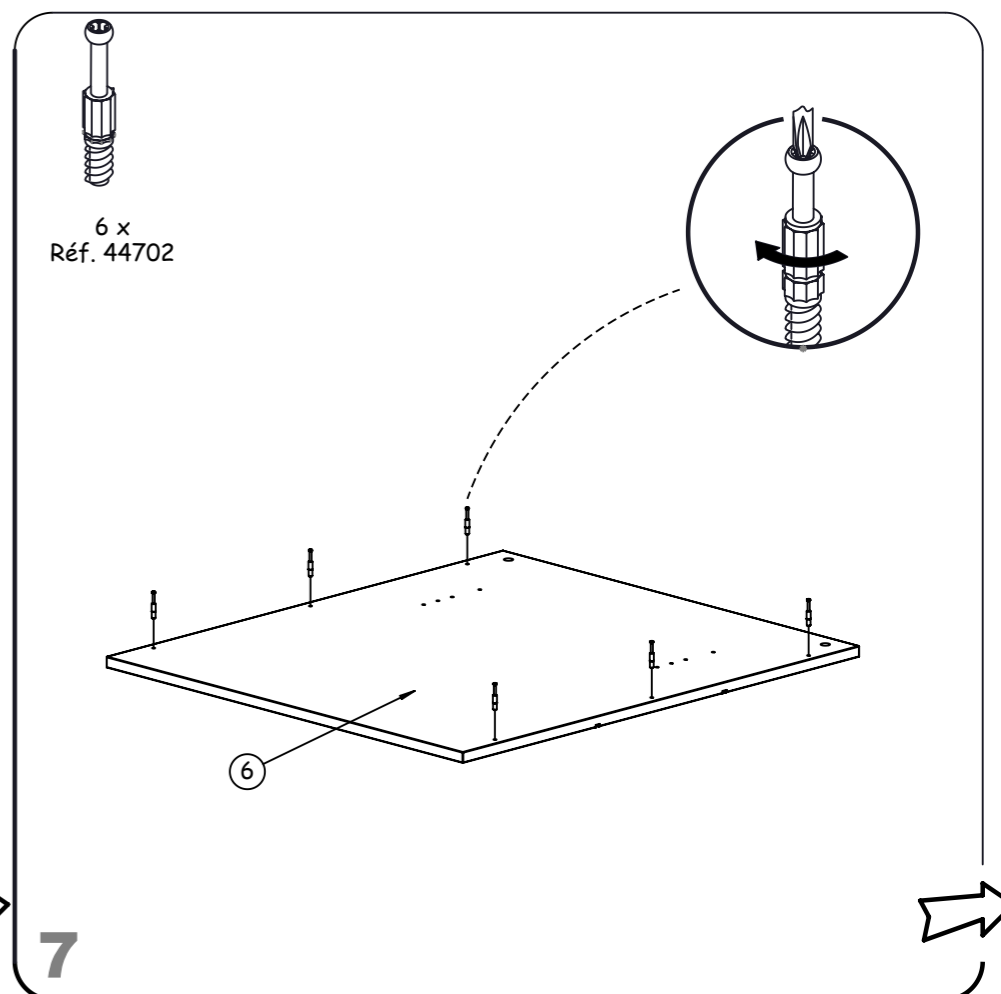
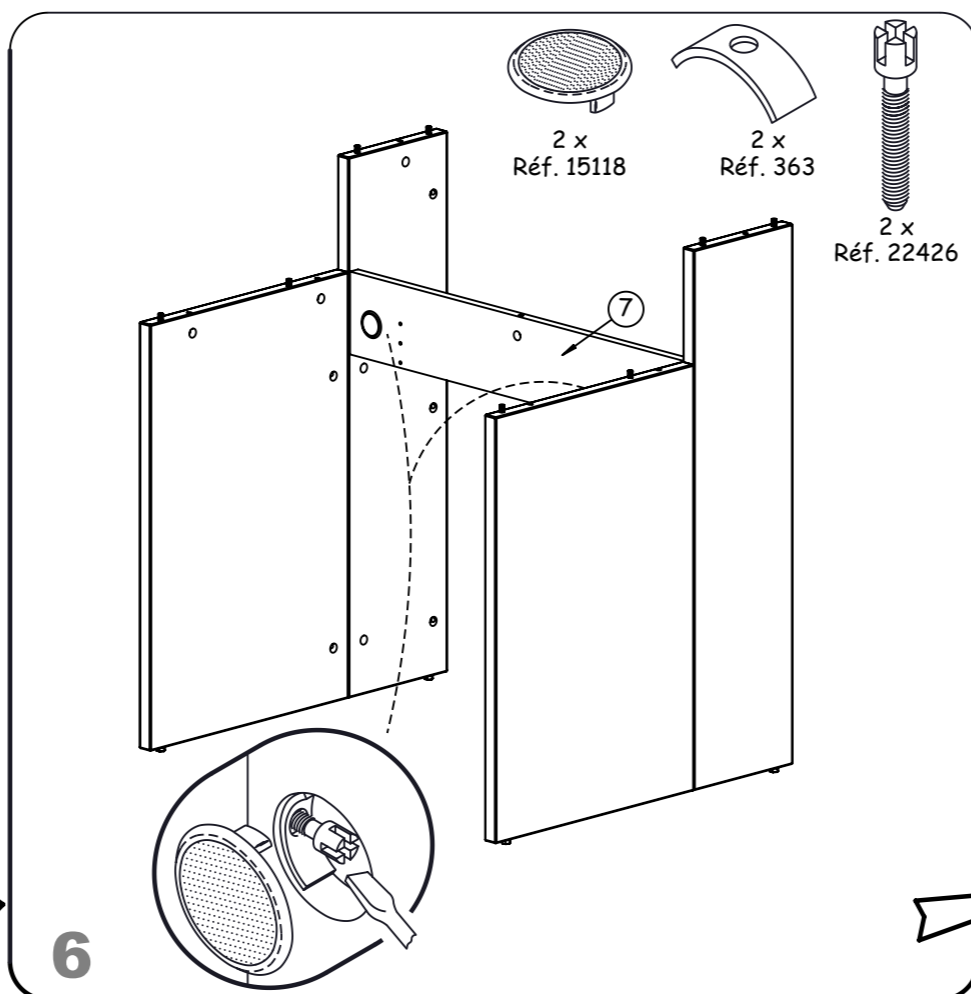
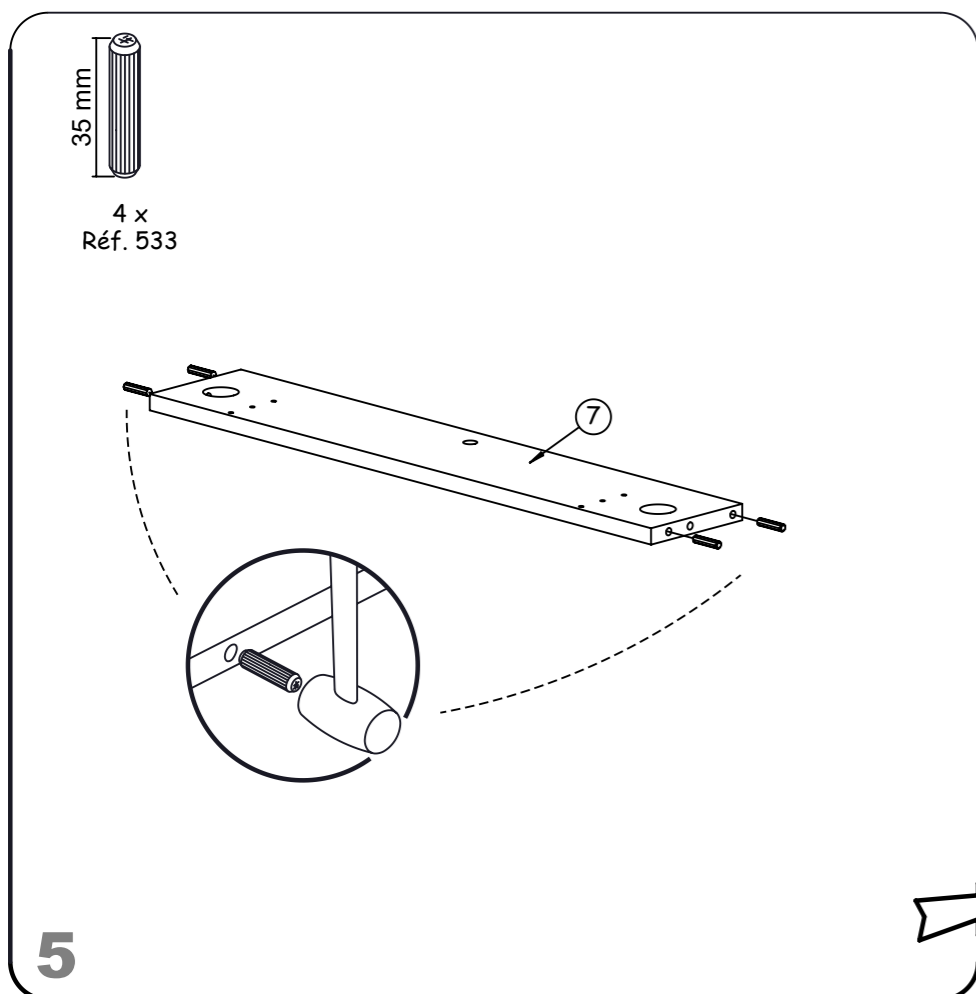
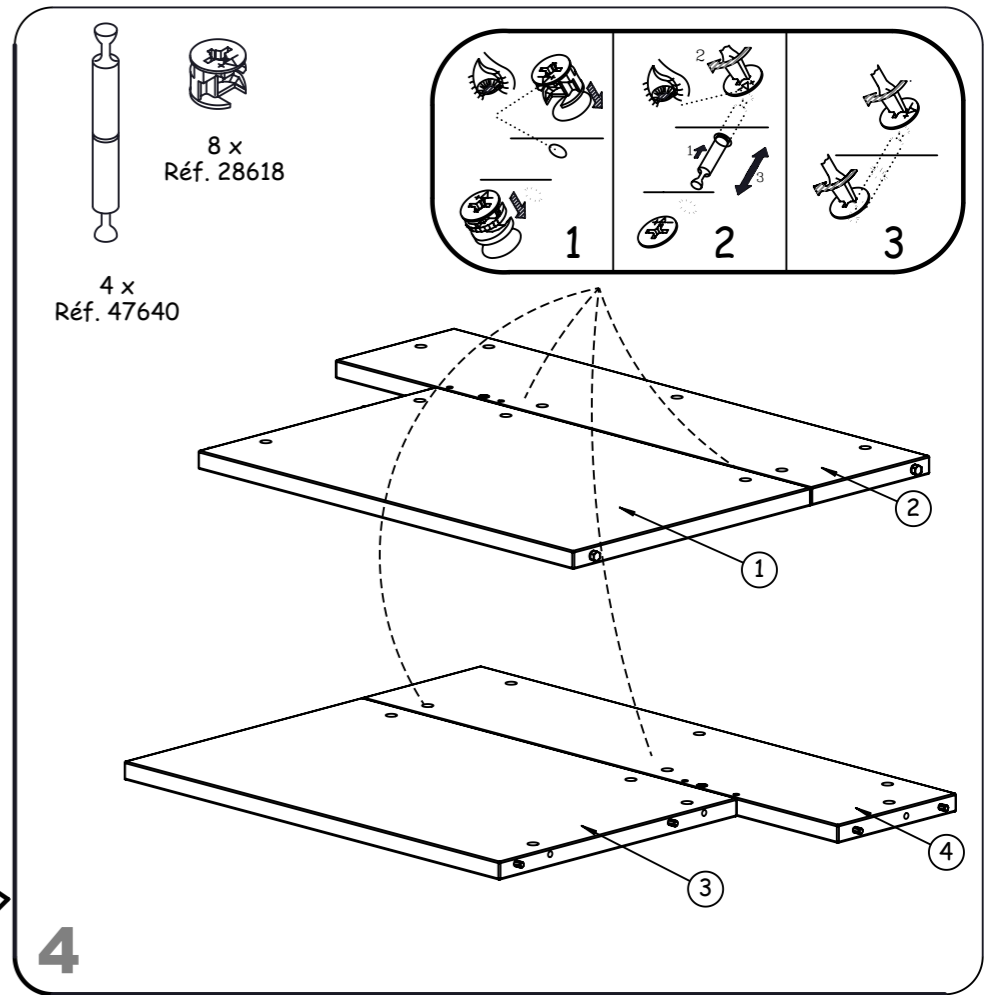
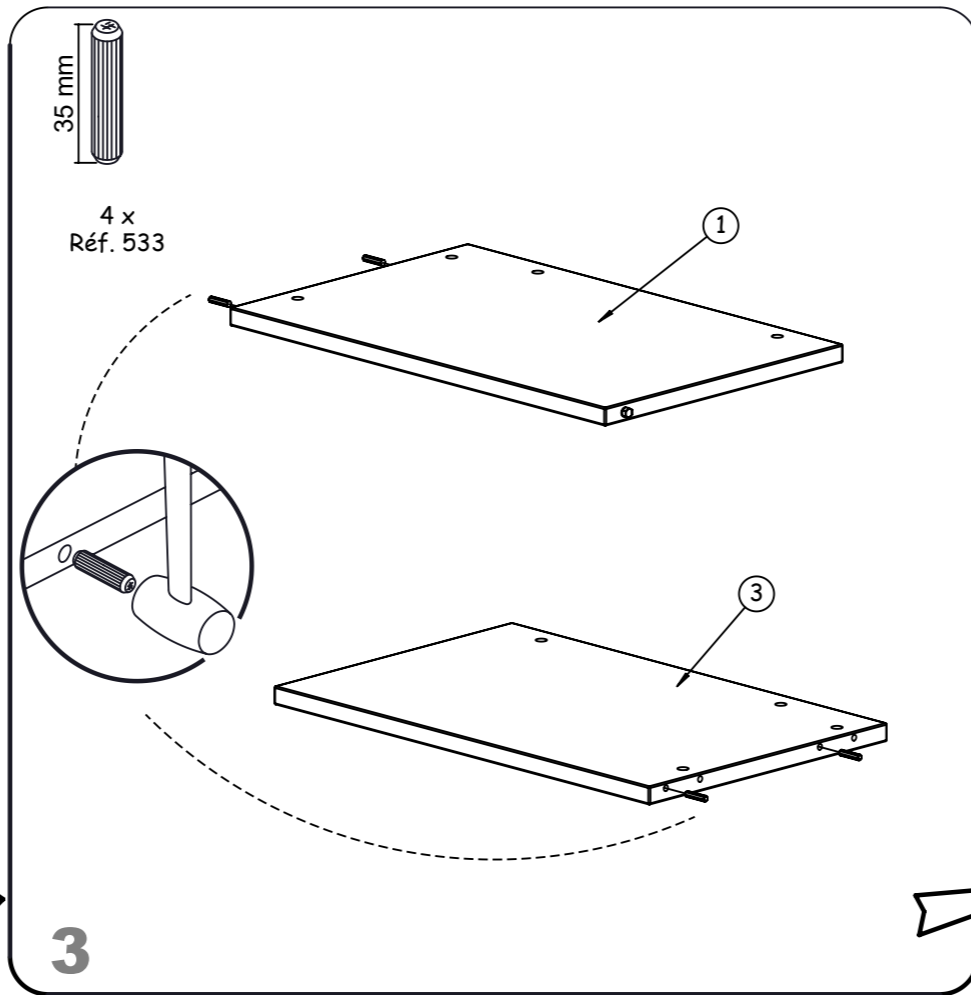
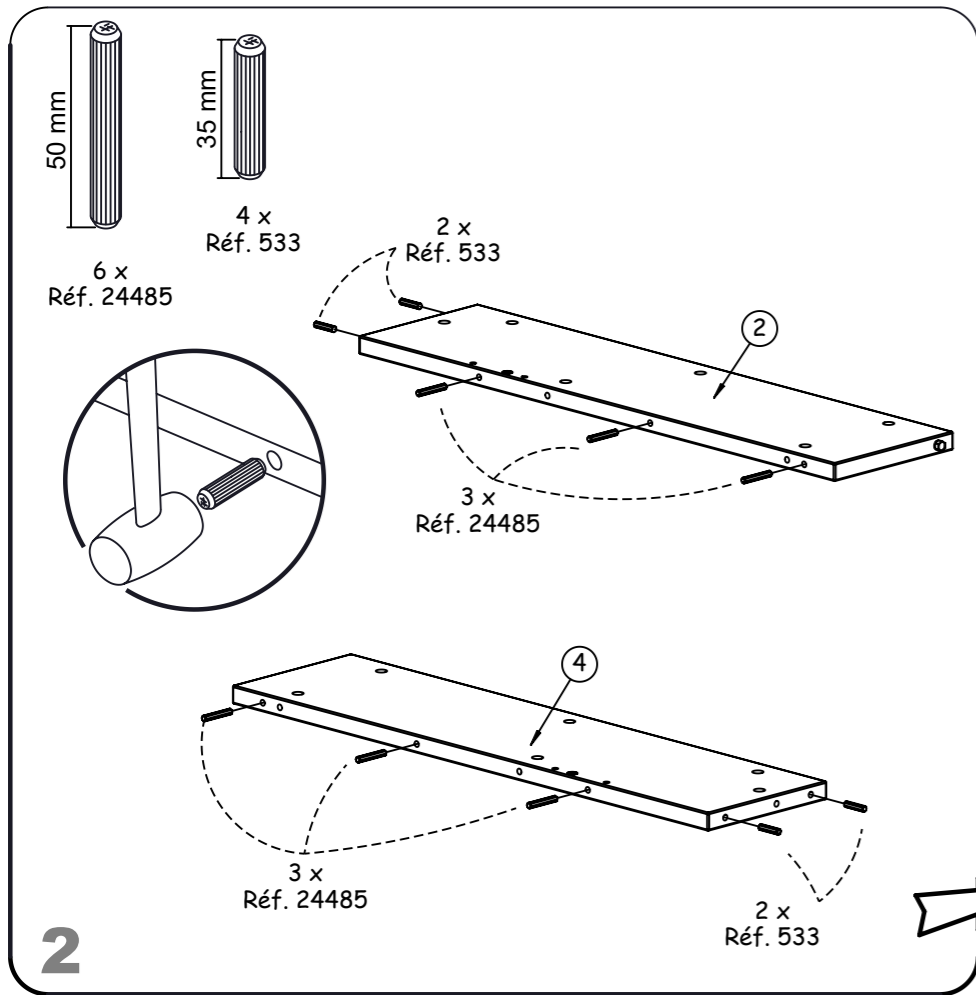

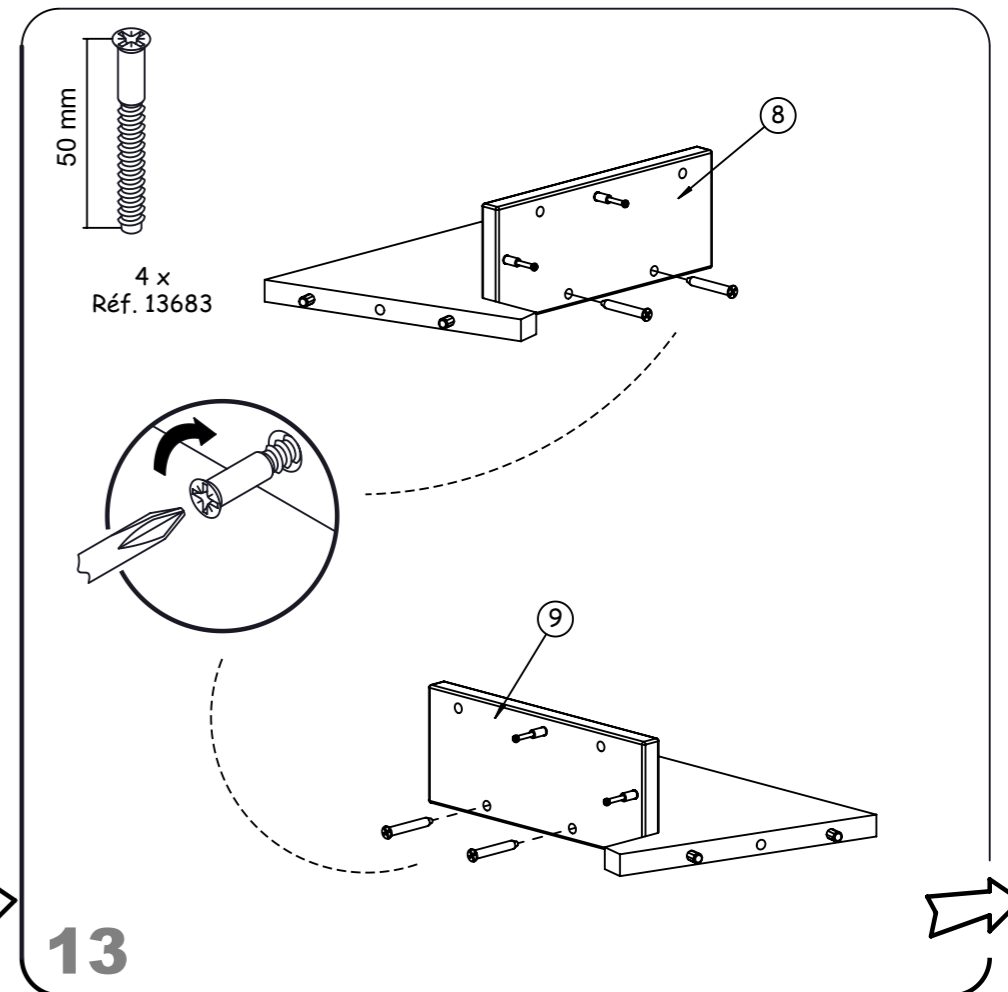
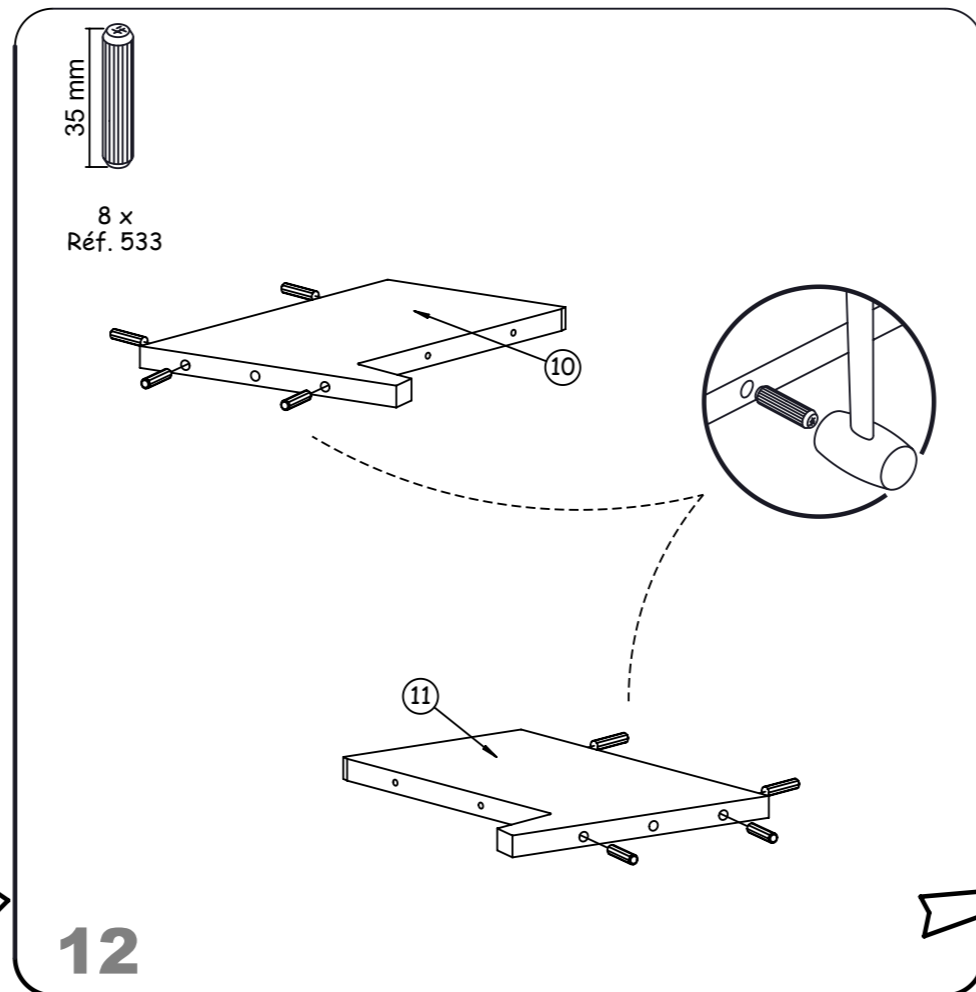
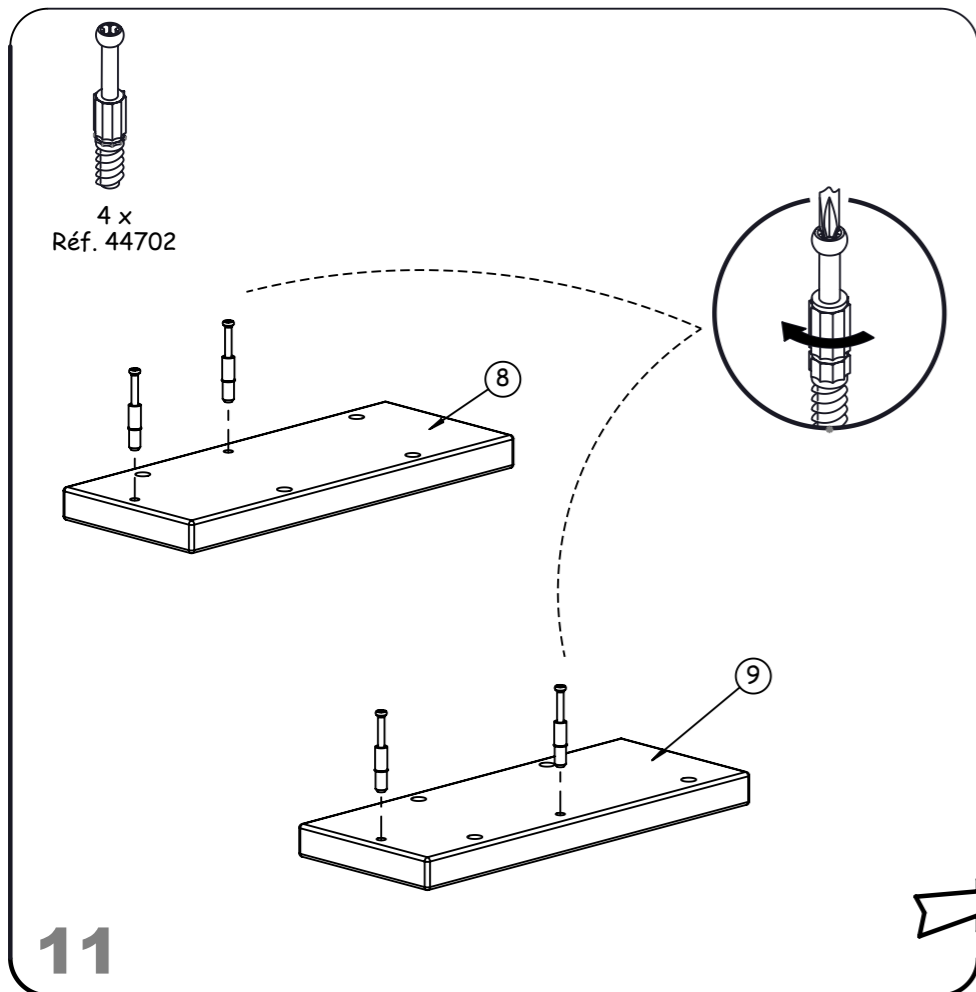
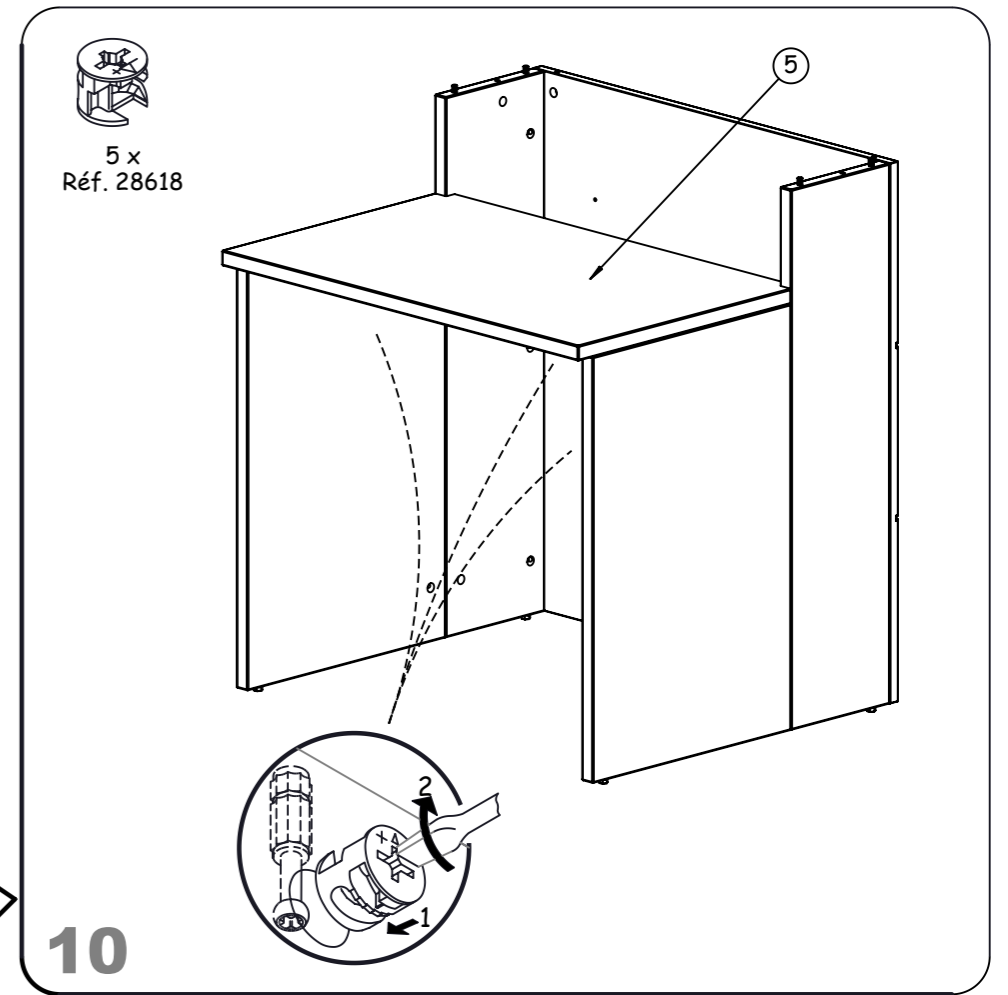
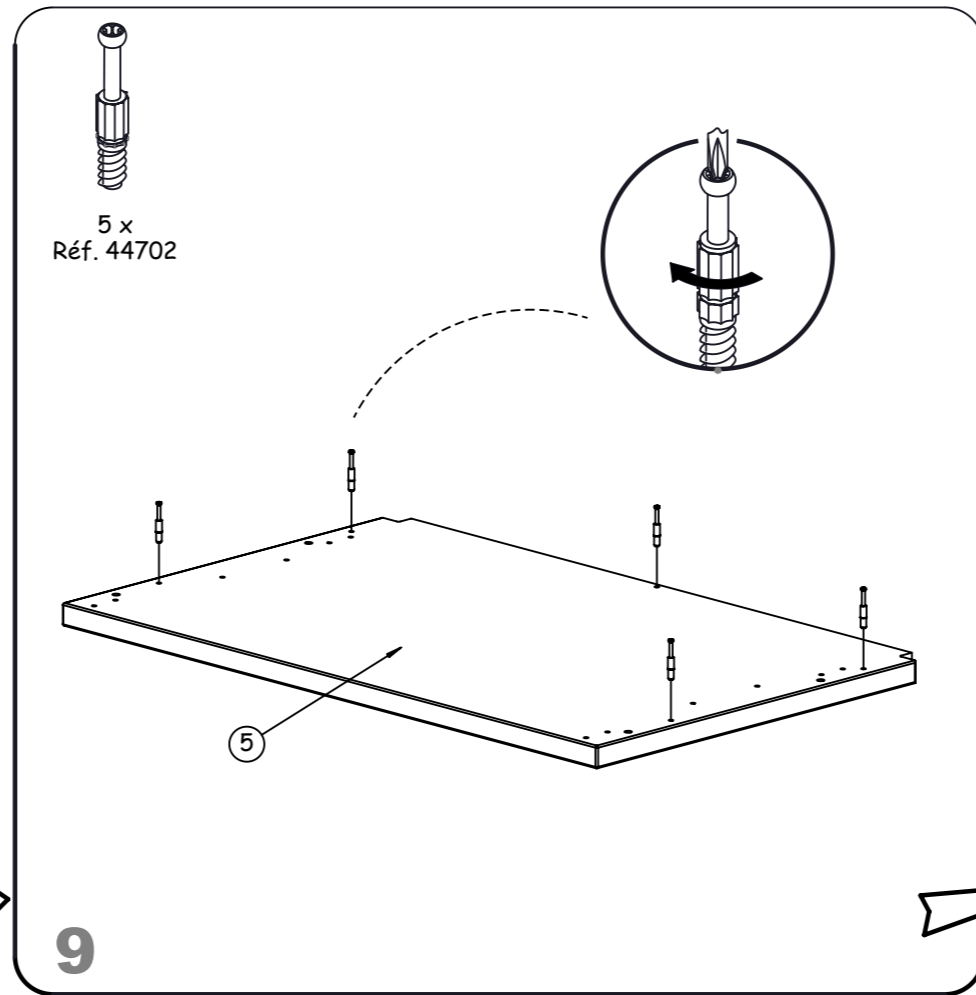
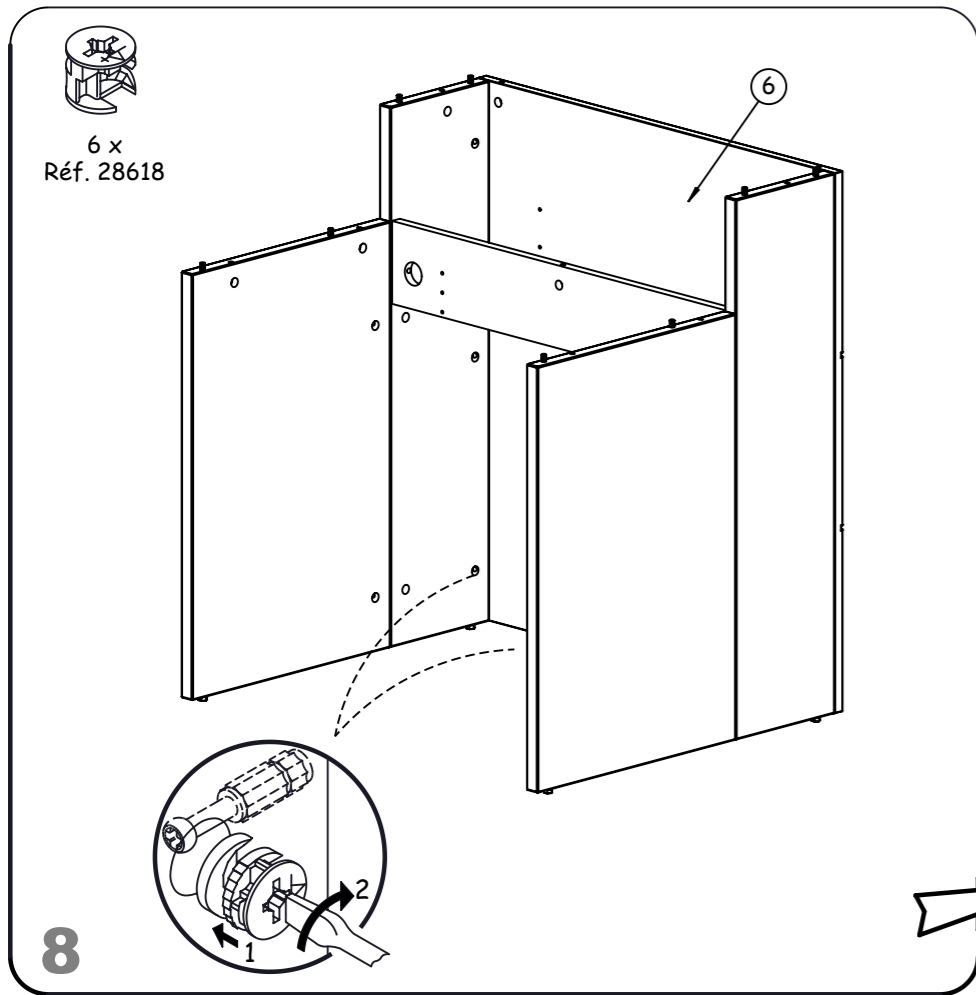

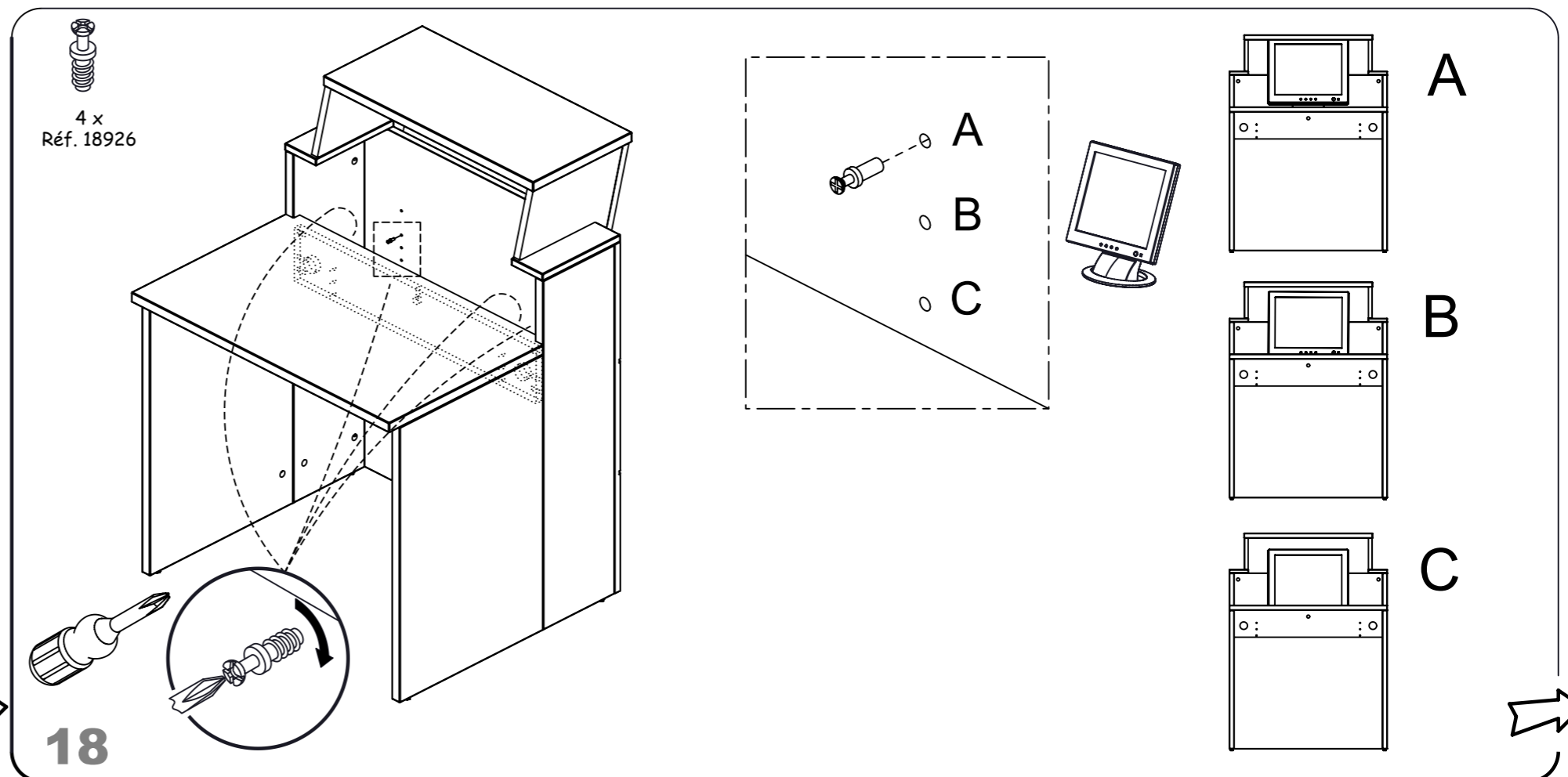
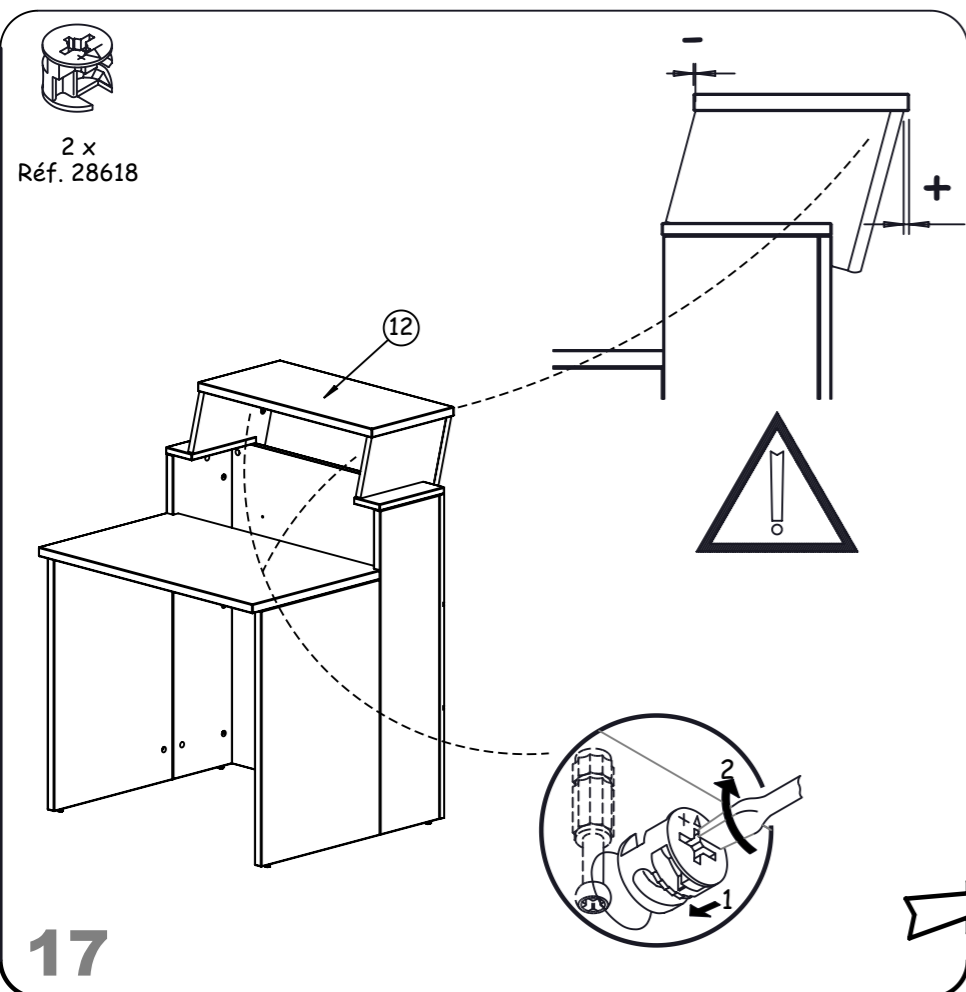
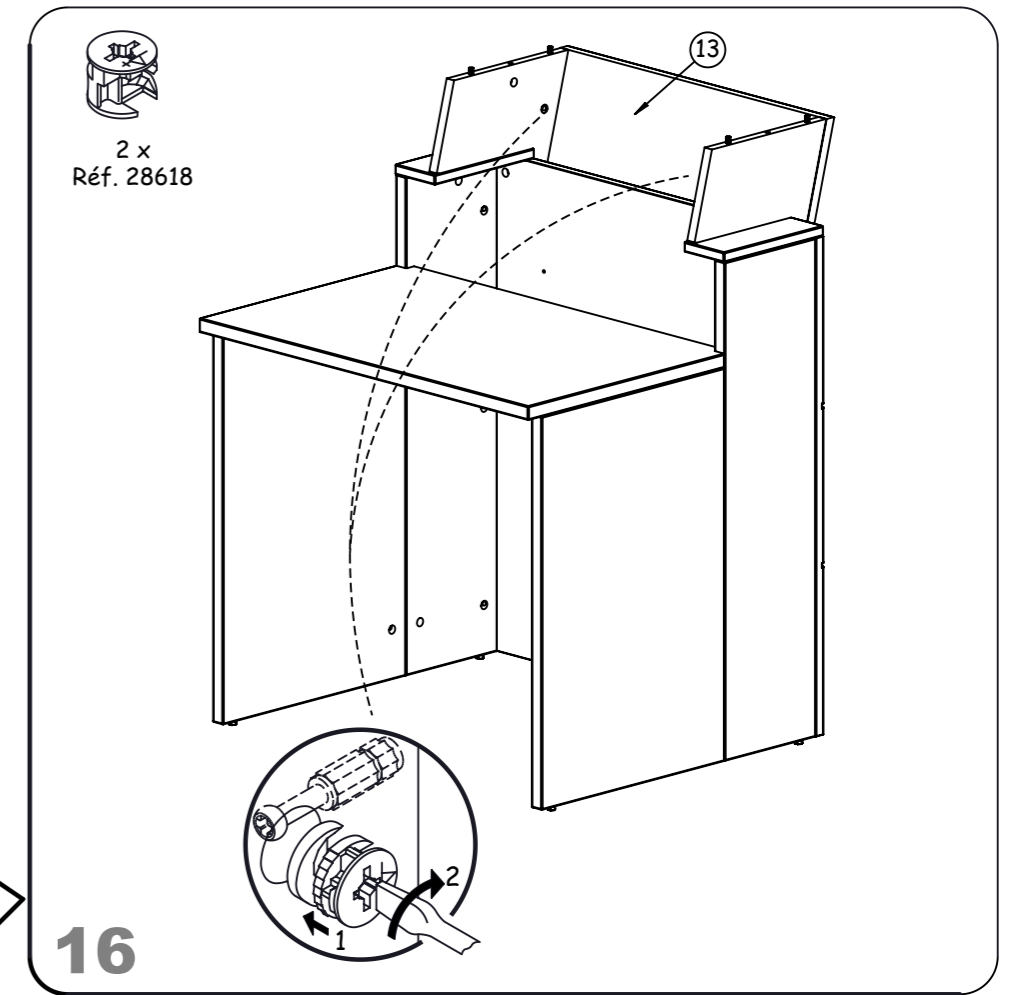
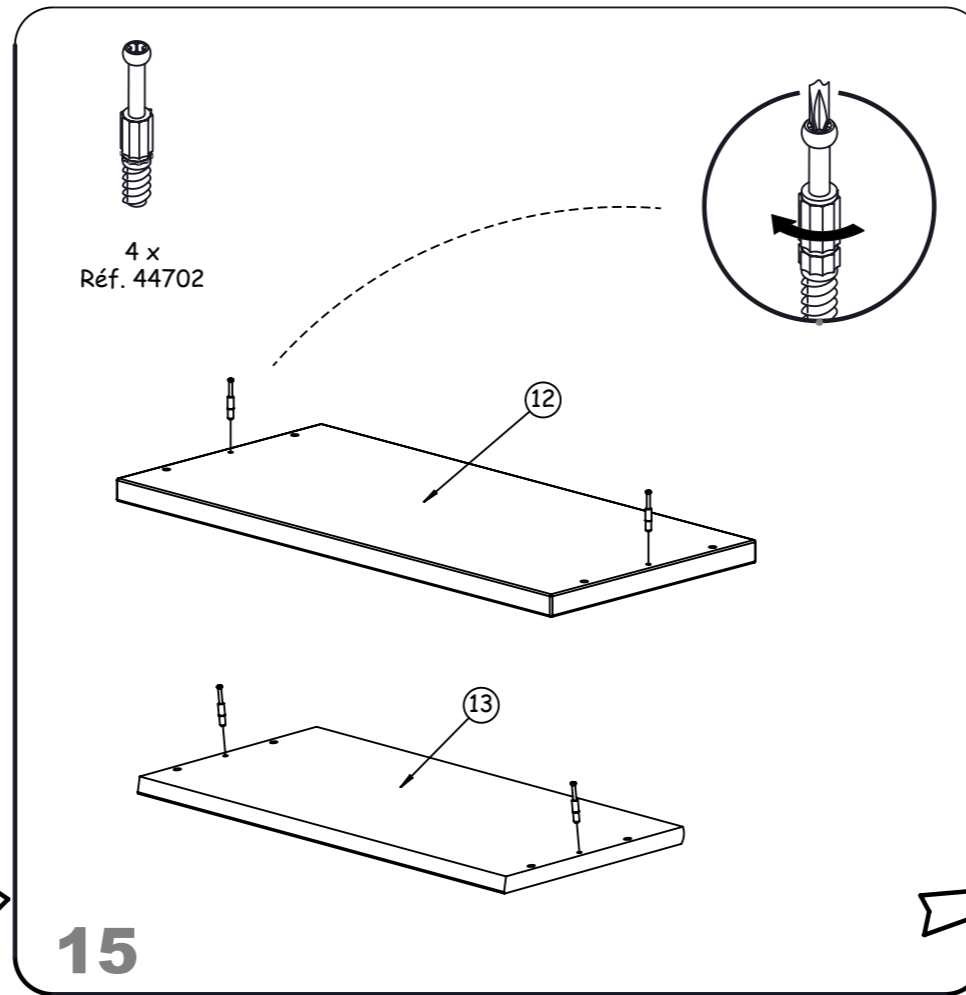
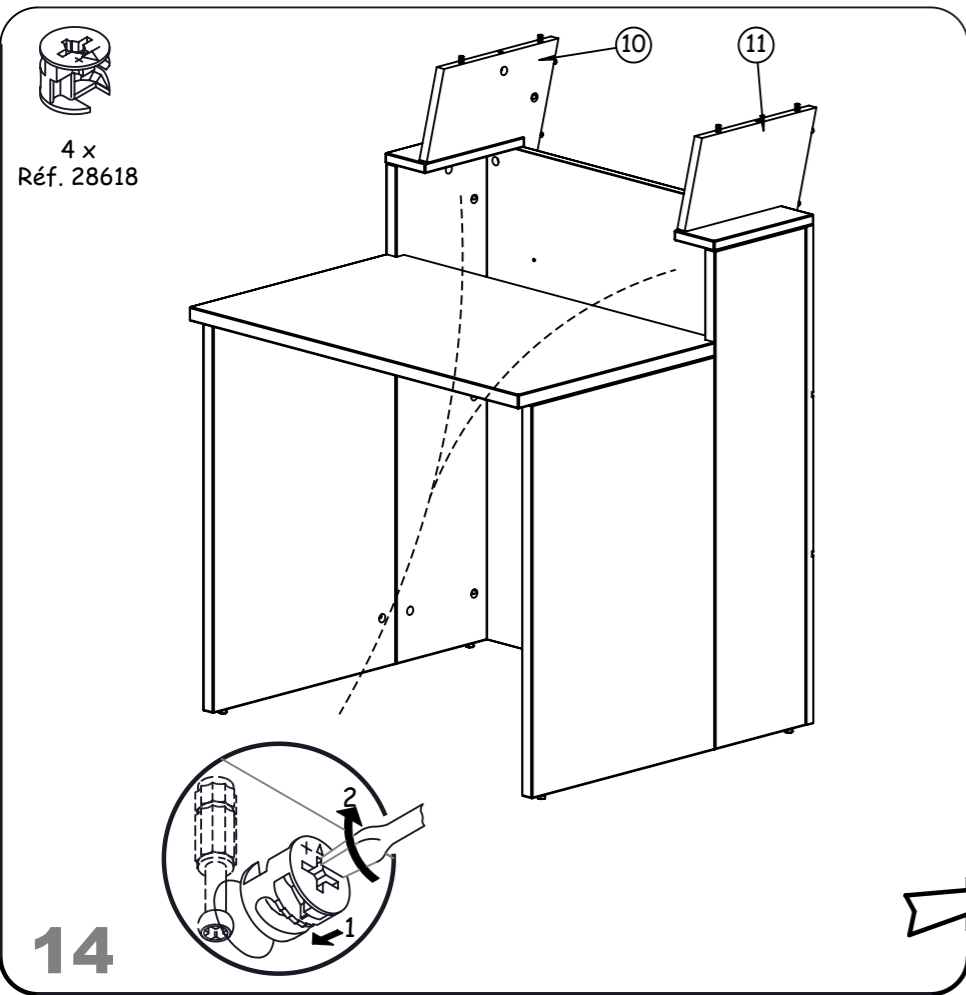

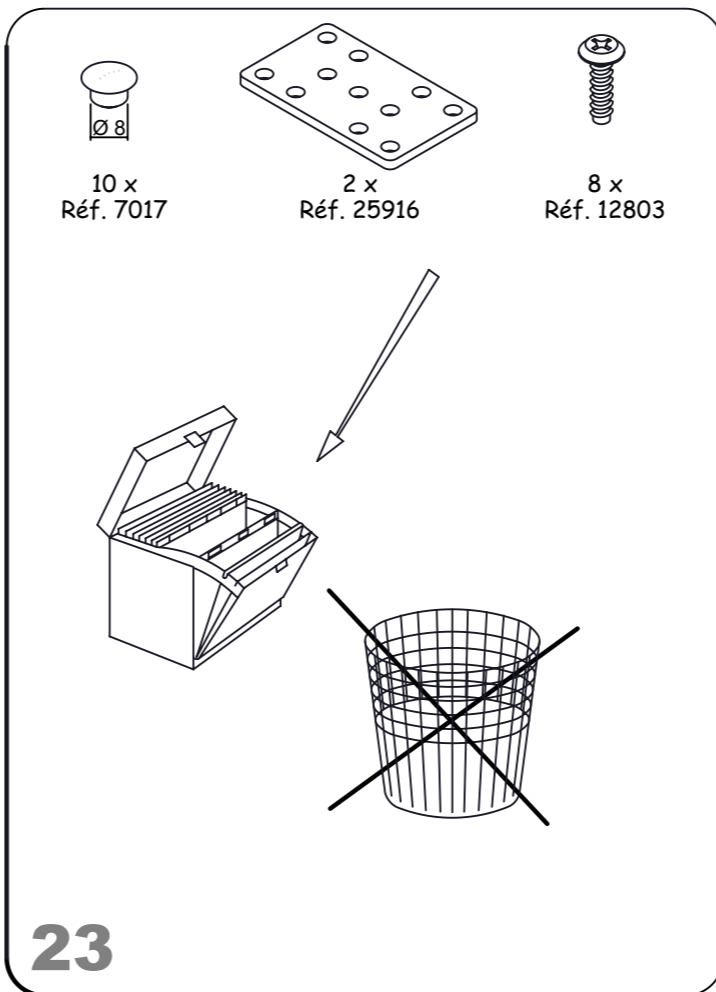
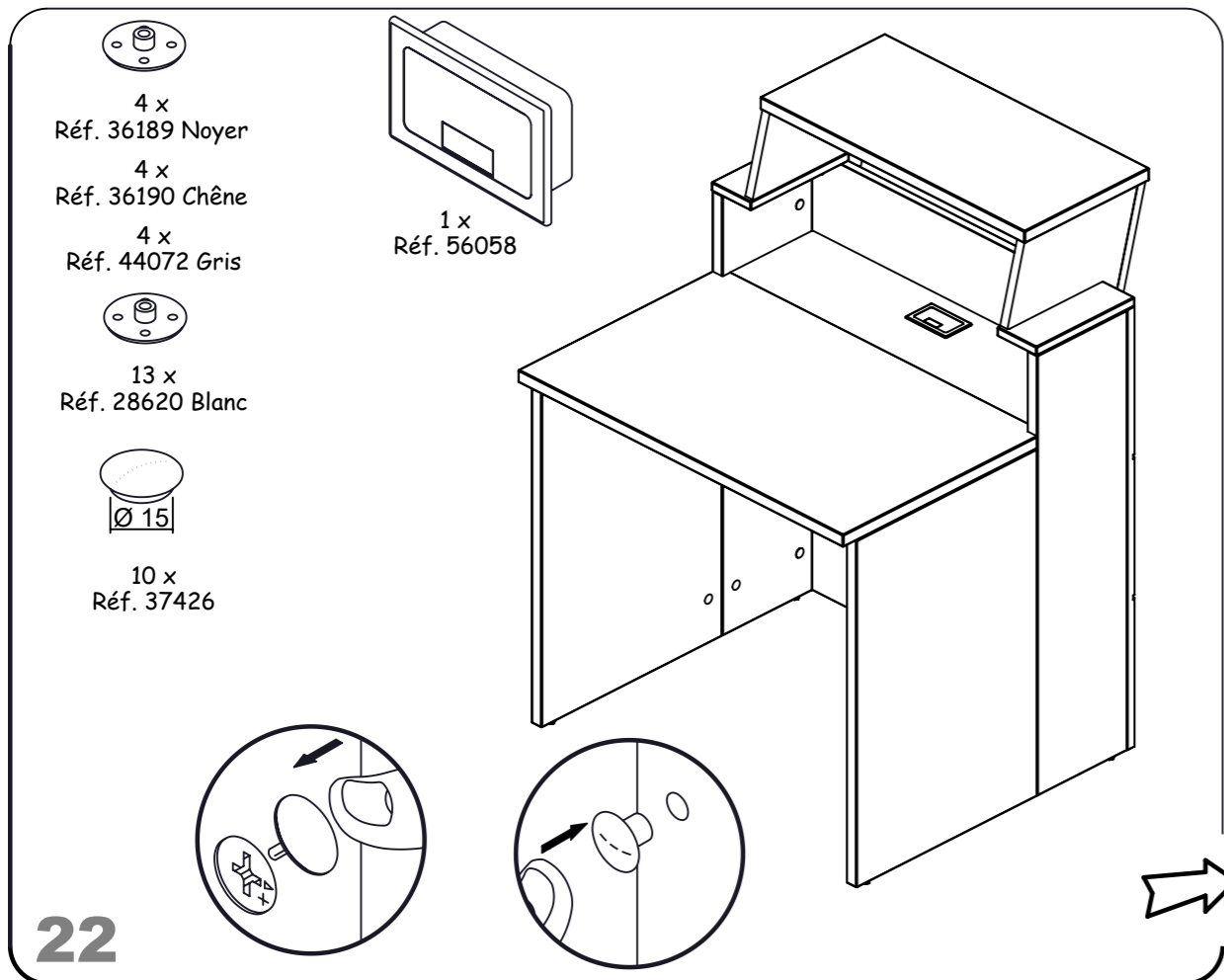
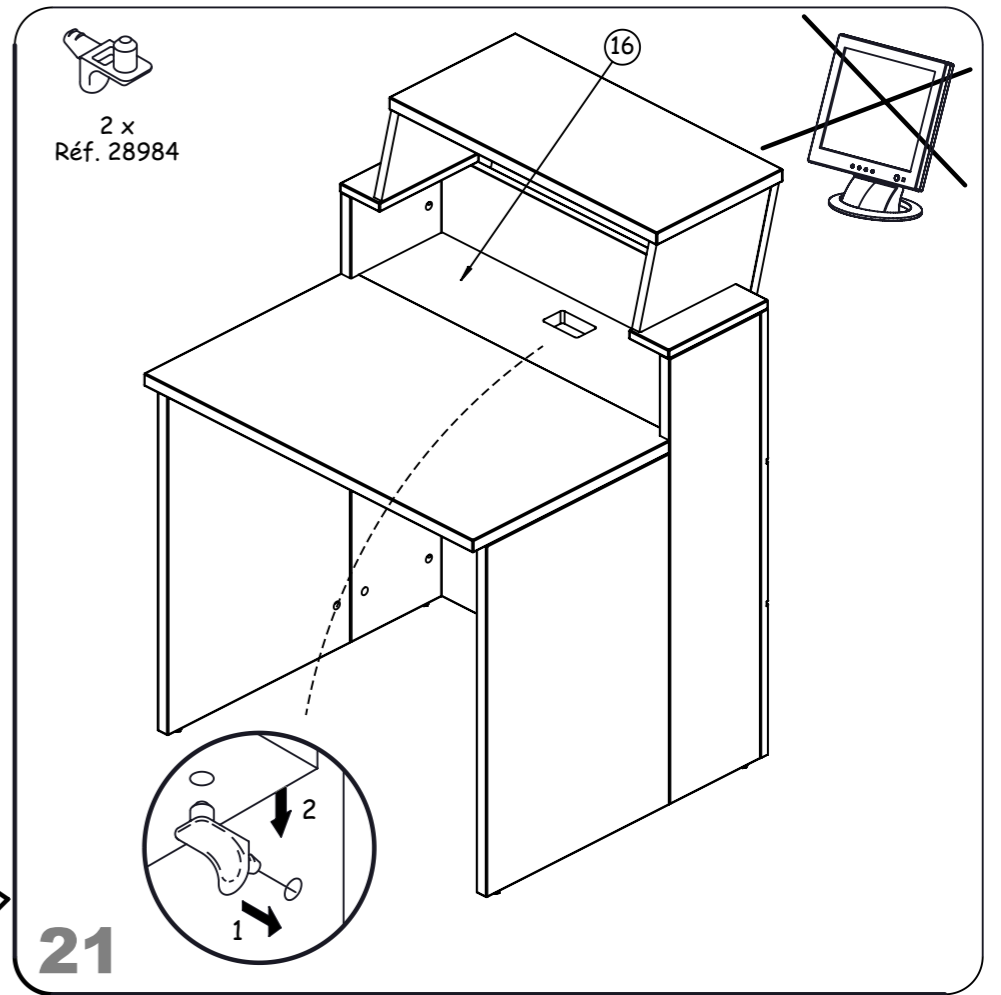
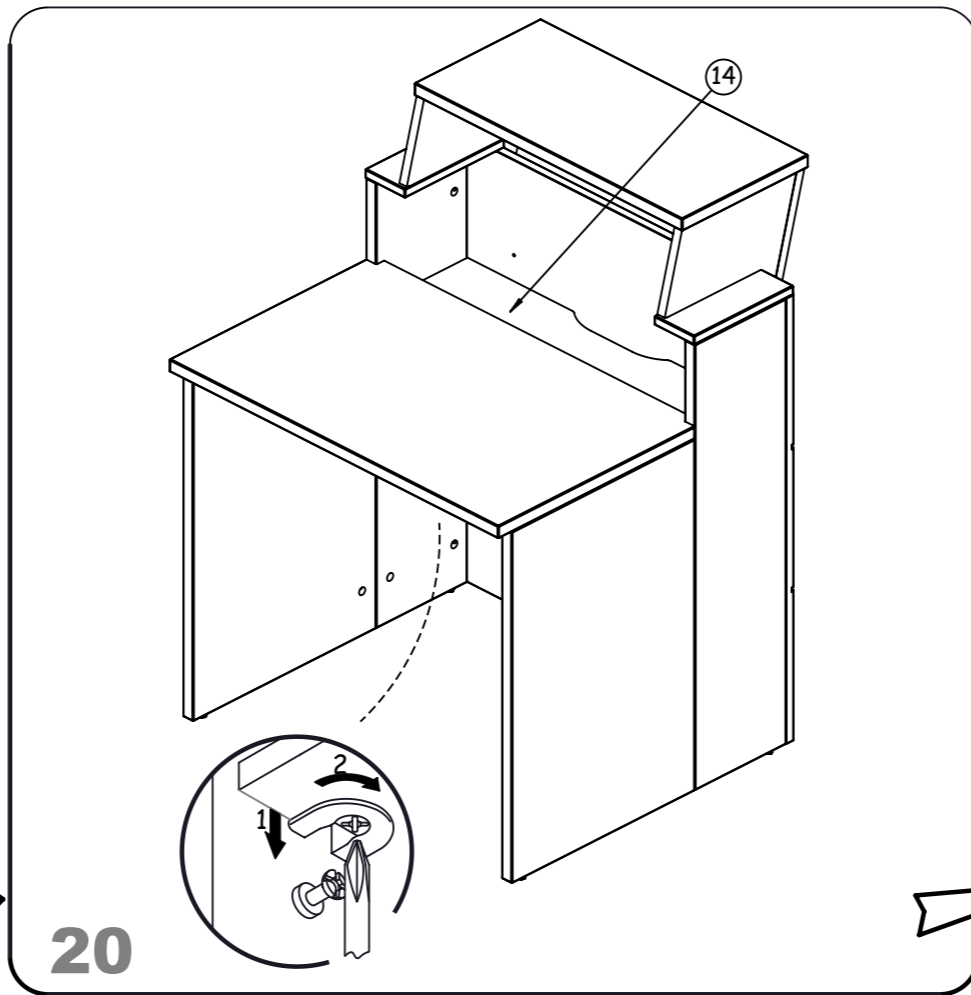
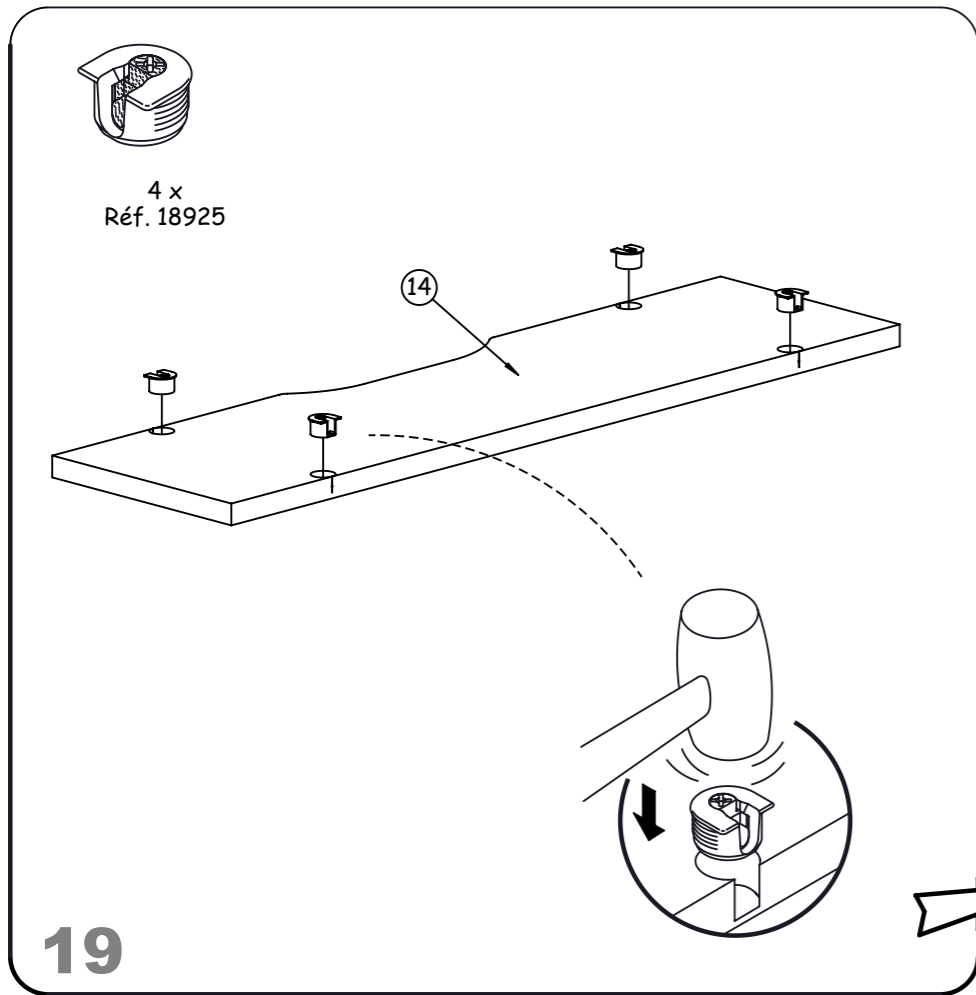

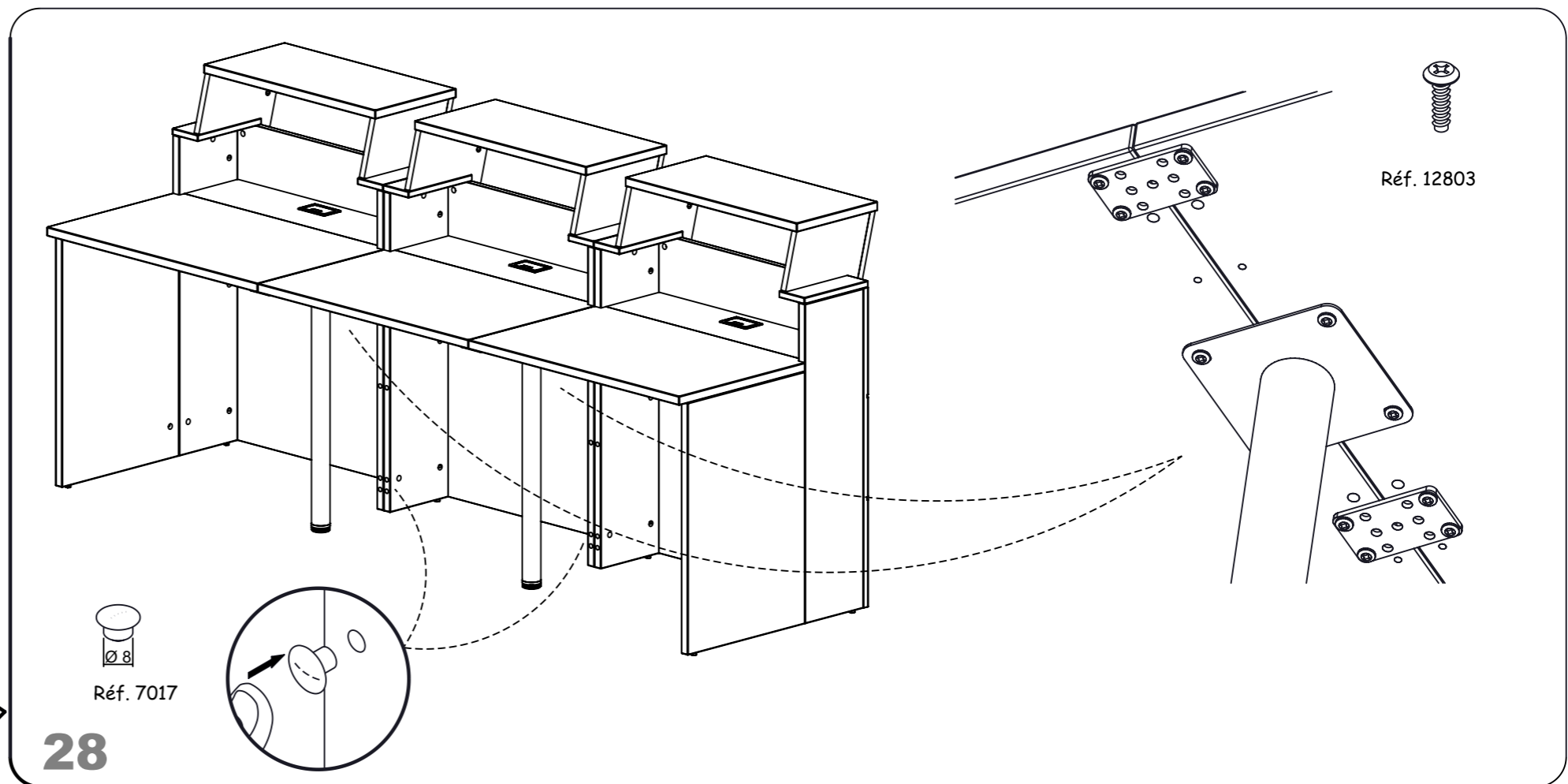
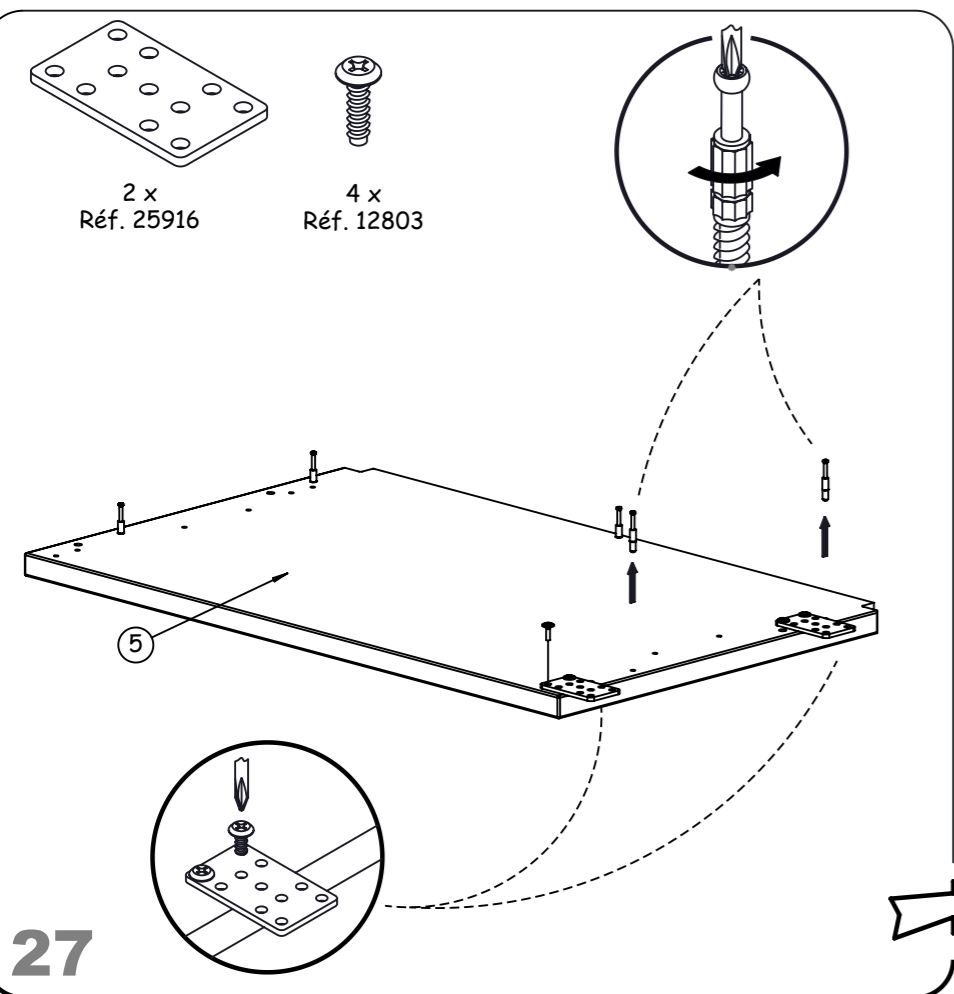
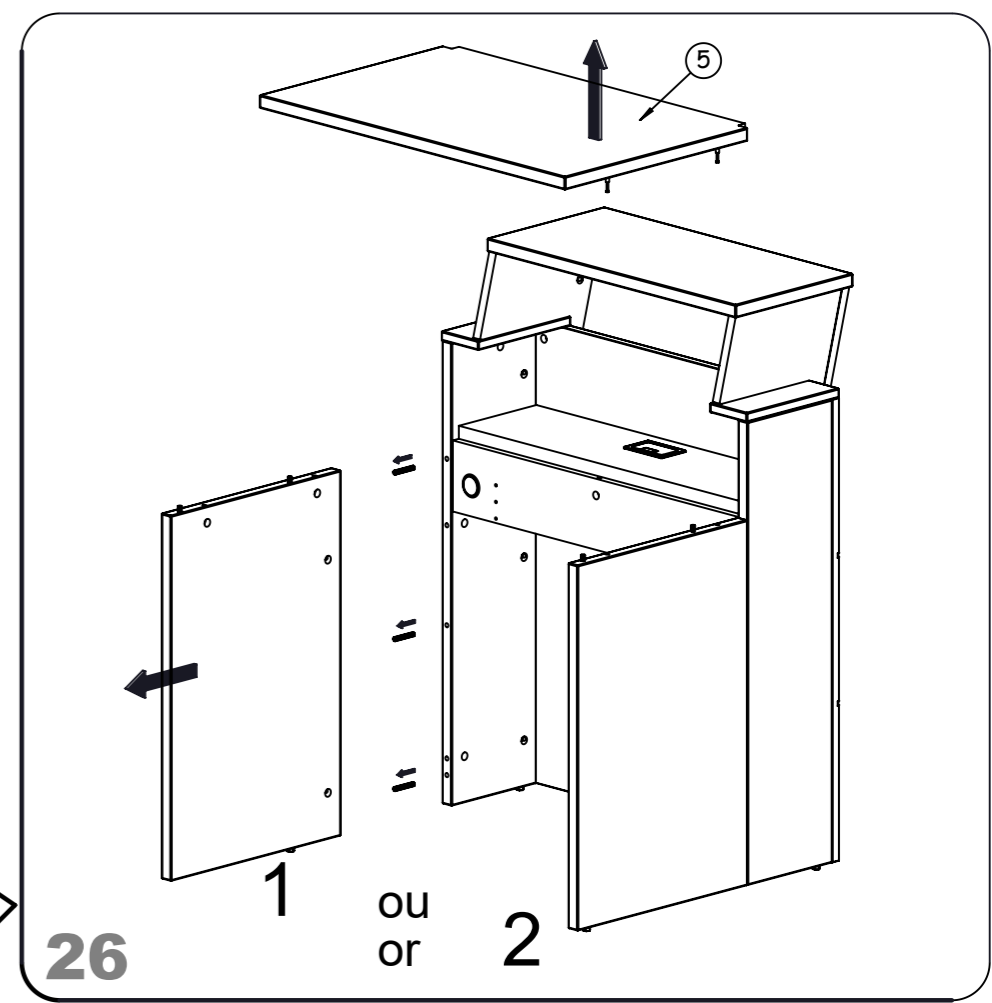
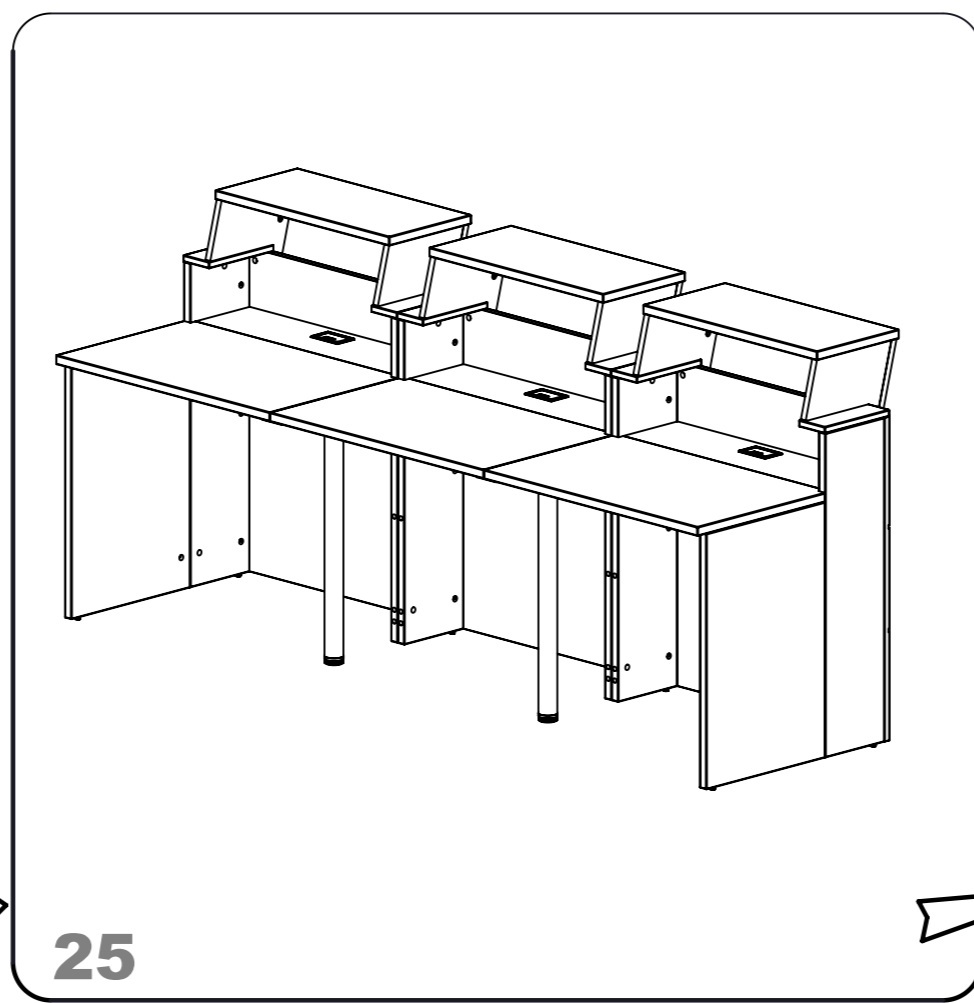
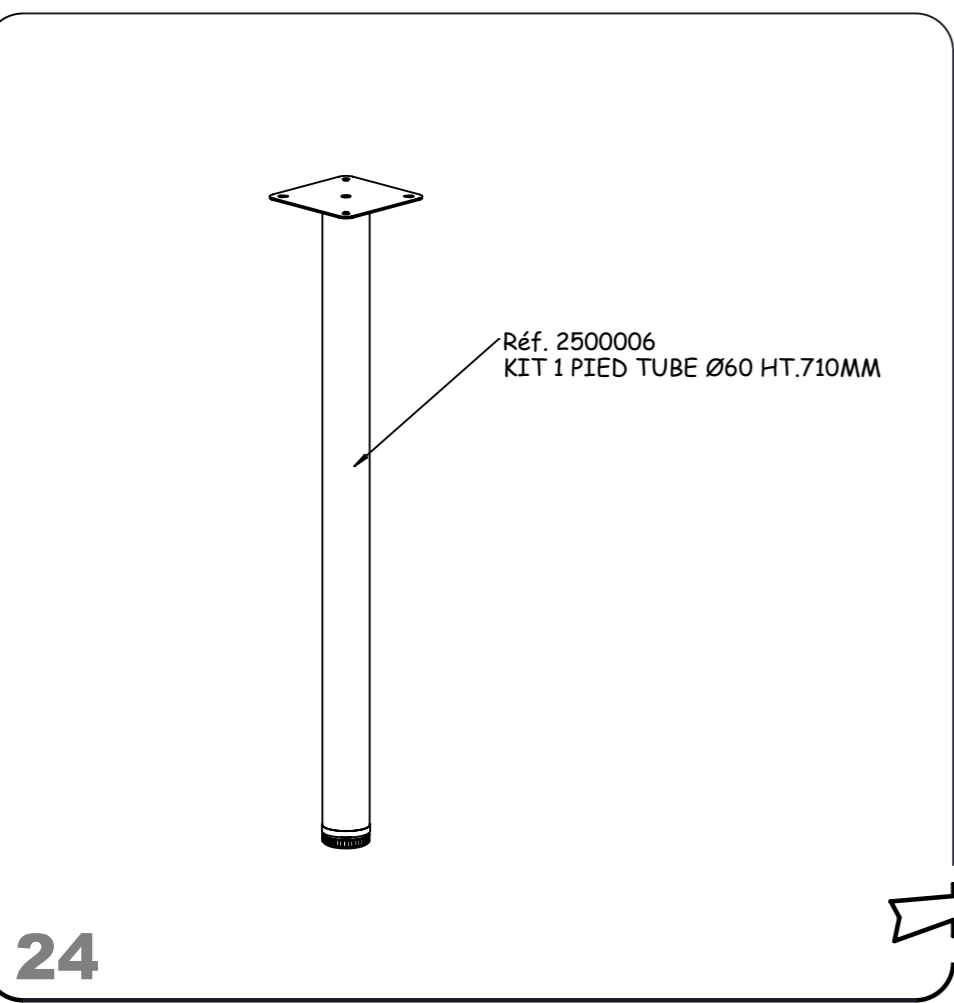

**INSTRUCTIONS DE RECYCLAGE - RECYCLING INSTRUCTIONS - INSTRUCCIONES DE RECICLAJE
 RECYCLING INSTRUCTIES - RECYCLING-ANWEISUNGEN - ISTRUZIONI DI RICICLAGGIO
 ИНСТРУКЦИЯ ПО УТИЛИЗАЦИИ - GERİ DÖNÜŞÜM TALİMATLARI**

FR Lors de l'élimination de votre mobilier usagé, les composants en bois, en plastique et en métal peuvent être séparés et être dirigés en déchetterie vers les contenants appropriés pour favoriser leur valorisation. Toutefois, si votre déchetterie est équipée d'une benne "meuble", vous pouvez déposer votre mobilier en l'état; l'éco-organisme gestionnaire de la filière DEA (www.eco-mobilier.fr) prendra en charge les opérations nécessaires à la valorisation optimale de celui-ci. Enfin n'oubliez pas que vous pouvez prolonger la durée de vie de vos produits usagés en contactant les associations caritatives de votre région.

GB When your furniture is no longer of use, its wood, plastic and metal components can be separated out and placed in the appropriate bins to be recycled. But remember that you may be able to extend the useful life of used furniture by passing it on to a charitable association in your neighbourhood.

ES Cuando elimine su mobiliario usado, los componentes de madera, plástico y metal pueden separarse y llevarse al vertedero y tirarse en los contenedores apropiados para su reciclaje. No obstante, no olvide que podrá prolongar la duración de vida de sus productos usados si se pone en contacto con las asociaciones de voluntariado social de su región.

NL Houten, plastic en metalen onderdelen van uw afgedankte meubels kunt u in gescheiden vorm aanbieden bij een afvalverzamelpunt en in de daarvoor bestemde containers werpen zodat ze opnieuw gebruikt kunnen worden. U kunt natuurlijk ook nog een tweede leven geven aan uw meubels door contact op te nemen met een liefdadigheidsinstelling bij u in de buurt.

DE Die Holz-, Kunststoff und Metallteile Ihrer Altmöbel können getrennt und in einem Wertstoffhof dem entsprechenden Recycling zugeführt werden. Ihre Altmöbel können jedoch auch für andere noch nützlich sein - wenden Sie sich an karitative Vereine in Ihrer Umgebung-Wohnregion.

IT Al momento dell'eliminazione del vostro mobile usato, i componenti in legno, in plastica ed in metallo possono essere separati ed essere portati in discarica verso i contenitori idonei per favorire la loro valorizzazione. Tuttavia, non dimenticate che potreste prolungare la durata di vita dei vostri prodotti usati contattando le associazioni caritative della vostra regione.

RU Для того, чтобы избавиться от старой мебели, можно рассортировать детали из дерева, пластика и металла и отправить в пункты сбора утиля для их переработки и вторичного использования. Однако, не забывайте, что вы можете продлить срок службы изделий, связавшись с благотворительными организациями вашего региона.

TR Eski mobilyanızı elden çıkarırken, ahşap, plastik ve metal bileşenler ayrıştırılabilir ve özel bir atık boşaltma yerinde tekrar değerlendirilmelerine katkıda bulunmak için uygun konteynirlara bırakılabilir. Ancak unutmayınız ki bölgenizdeki hayır kurumlarıyla irtibata geçerek eskimiş ürünlerinizin ömrünü uzatabilirsiniz.

**Merci de garder ce document pendant toute la vie du produit.
 Please conserve this document all along the product life.**

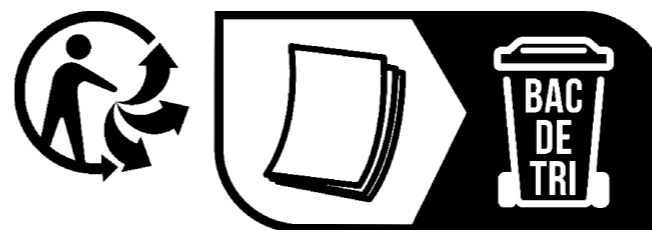

<https://quefairedemesdechets.fr>

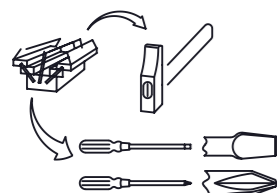

CONSEILS D'ENTRETIEN :

- Nous vous recommandons de nettoyer nos meubles exclusivement à l'aide d'un chiffon doux imbibé d'eau savonneuse et de les essuyer avec un chiffon sec,

HINTS ON CARE :

- We recommend that you clean our furniture using only a soft cloth rung out in soapy water, and then polish it with a dry duster;

CONSEJOS PARA EL CUIDADO :

- Le recomendamos que limpie nuestros muebles exclusivamente con un trapo suave empapado de agua y jabón y que los seque con un trapo seco,

ONDERHOUD :

- Wij adviseren onze meubelen te reinigen met een zachte doek met zeepwater doordrenkt en met een droge doek af te drogen.

PFLEGEVORSCHRIFTEN :

- Zur Reinigung empfehlen wir einen weichen, in Seifenwasser getränkten Lappen. Trocknen Sie anschließend das Möbelstück mit einem trockenen Lappen.

MANUTENZIONE :

- Vi raccomandiamo di pulire i nostri mobili con l'aiuto di uno straccio morbido imbevuto di acqua insaponata e di asciugarli con uno straccio asciutto,

СОВЕТЫ ПО УХОДУ ЗА МЕБЕЛЬЮ:

- Рекомендуется чистить мебель только при помощи влажной тряпки, смоченной мыльной водой, с последующим протиранием сухой тряпкой.

MANUTENÇÃO :

- Recomendamos que a limpeza dos nossos móveis seja feita apenas com um pano suave embebido em água e sabão e de seguida enxugado com um pano seco,

GARANTIE :

- Si, malgré tous nos contrôles, vous constatez une anomalie, nous vous remercions de préciser sa nature, le numéro de la ou les pièces défectueuses ainsi que les références et **"N° de série"** de votre meuble auprès de votre distributeur.

GARANTEE :

- If, despite all our verifications, you notice an anomaly, kindly describe the nature of the anomaly, the number of the defective item or items, as well as the your distributor's reference number and **"N° de série"** for your piece of furniture.

GARANTIA :

- Si pese a todos nuestros controles detectas una anomalía, te agradecemos que le indiques a tu distribuidor su naturaleza, el número de la o de las piezas defectuosas así como las referencias y **"N° de série"** del mueble.

WAARBORG :

- Als u, ondanks al onze controles, toch een anomalie vaststelt, vragen we u om contact op te nemen met uw distributeur, en de aard van het probleem te beschrijven. De distributeur zal u om het nummer van het defecte onderdeel of de nummers van de defecte onderdelen, en de referenties en het **"N° de série"** van uw meubel verzoeken.

GARANTIE :

- Sollten Sie trotz unserer durchgeführten Kontrollen einen Mangel feststellen, melden Sie diesen bitte Ihrem Händler unter Angabe der Art des Mangels, der Nummer des bzw. der fehlerhaften Teile sowie der Referenzen und **"N° de série"** Ihres Möbels.

GARANZIA :

- In caso venissero riscontrate anomalie nonostante tutti i nostri controlli, indicare al rivenditore la natura del difetto, il numero del pezzo o dei pezzi difettosi, le referenze e il **"N° de série"** del mobile.

ГАРАНТИЯ :

- Если, несмотря на все наши меры по контролю, вы находите неисправность, просим вас указать ее природу, номер неисправной(-ых) детали(-ей), а также артикулы и **"N° de série"** вашей единицы мебели у вашего дистрибьютора.

GARANZIA :

- Se, apesar de todos os nossos controlos, detetar uma anomalia, pedimos que a pormenorize, indique o número da peça ou peças defeituosas bem como as referências e **"N° de série"** do seu móvel junto do seu distribuidor.

NF ENVIRONNEMENT AMEUBLEMENT

www.nf-environnement-ameublement.com

FR Caractéristiques certifiées

- Limitation des impacts sur l'environnement tout au long du cycle de vie
- Garantie de la qualité et de la durabilité du mobilier

Afin d'assurer le prolongement de la durée d'usage d'un produit nous nous engageons à fournir, durant 5 années à compter de la date d'arrêt de production, les éléments fonctionnels d'origine ou des éléments remplissant des fonctions équivalentes.

GB In order to ensure our products enjoy a long life, we are committed to providing the functional elements, or equivalent elements serving the same function, of a product for 5 years from the date that product ceases to be in production.

ES Para garantizar una larga vida útil de los productos, nos comprometemos a ofrecer, durante los 5 años siguientes a la fecha de cese de producción, los elementos funcionales originales o elementos que sustituyan funciones equivalentes.

NL Om een product zo lang mogelijk mee te laten gaan, verbinden we ons ertoe om gedurende een periode van 5 jaar, vanaf de datum van stopzetting van de productie, de onderdelen in een originele of aangepaste versie te leveren.

DE Um die Nutzungsdauer unserer Produkte zu verlängern, verpflichten wir uns, für eine Dauer von 5 Jahren ab dem Zeitpunkt der Produktionseinstellung die Original-Funktionselemente bzw. Elemente mit gleichwertigen Funktionen bereitzustellen.

IT Per garantire la longevità della vita utile di un prodotto, ci impegniamo a fornire per un periodo di 5 anni a partire dalla data di cessazione della produzione gli elementi funzionali originari o elementi con funzioni equivalenti

RU Для обеспечения продления срока службы изделия наша компания обязуется в течение 5 лет с даты прекращения производства поставлять оригинальные функциональные элементы или элементы, выполняющие эквивалентные функции.

PT De modo a assegurar o prolongamento da duração de utilização de um produto, comprometemo-nos a fornecer, durante 5 anos a partir da data de interrupção de produção, os elementos funcionais de origem ou elementos que cumpram funções equivalentes

N° Série:

GAUTIER FRANCE BP 10 85510 LE BOUPERE FRANCE



contact@gautier.fr