

GAUTIER

- D11-PREFACE Blanc
- D12-PREFACE Chêne gris
- D13-PREFACE Chêne sierra
- D15-PREFACE Chêne naturel
- D18-PREFACE Chêne du Bocage
- D19-PREFACE Noir

BIBLIOTHEQUE D'ANGLE 155

REF. 204

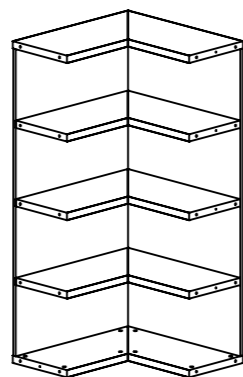

- FR - IMPORTANT - A lire soigneusement - A conserver pour consultation ultérieure
- GB - IMPORTANT - Read carefully and keep for information later
- ES - IMPORTANTE - Leer atentamente y guardar para consultas posteriores
- NL - BELANGRIJK, Lees deze instructies aandachtig en bewaar ze zodat u ze later nog kunt raadplegen
- DE - WICHTIGER HINWEIS. Bitte lesen sie diese unterlagen aufmerksam durch und bewahren sie sie auf
- IT - IMPORTANTE - Da leggere attentamente e da conservare per una ulteriore consultazione.
- RU - Это важно! Внимательно прочитайте данную инструкцию и сохраните ее для того, чтобы в дальнейшем при необходимости к ней обращаться.
- TR - ÖNEMLI, Dikkatli şekilde okuyunuz ve daha sonra başvurmak üzere saklayiniz.

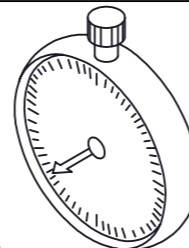
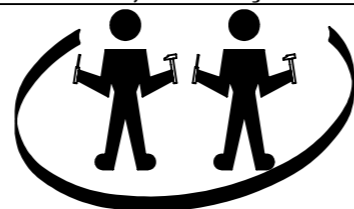

0H40

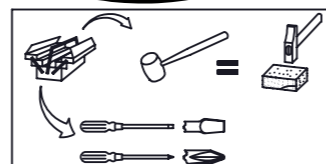

- 8 x Réf. 59595 (D12)
- 8 x Réf. 59593 (D13)
- 8 x Réf. 59589 (D15)
- 8 x Réf. 64311 (D18)
- 8 x Réf. 64314 (D19)



- 3 x Réf. 59594 (D12)
- 3 x Réf. 59592 (D13)
- 3 x Réf. 59588 (D15)
- 3 x Réf. 64452 (D18)
- 3 x Réf. 64581 (D19)

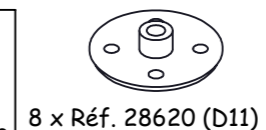

8 x Réf. 28620 (D11)



12 x Réf. 12168 (D11)

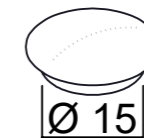

40 x Réf. 37426 (D11)



4 x Réf. 7017 (D11)



48 x Réf. 62370

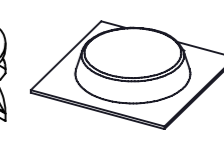

8 x Réf. 57298



28 x Réf. 62366

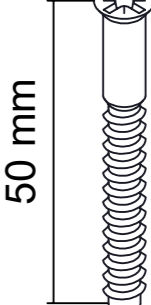

12 x Réf. 13683



10 x Réf. 62369

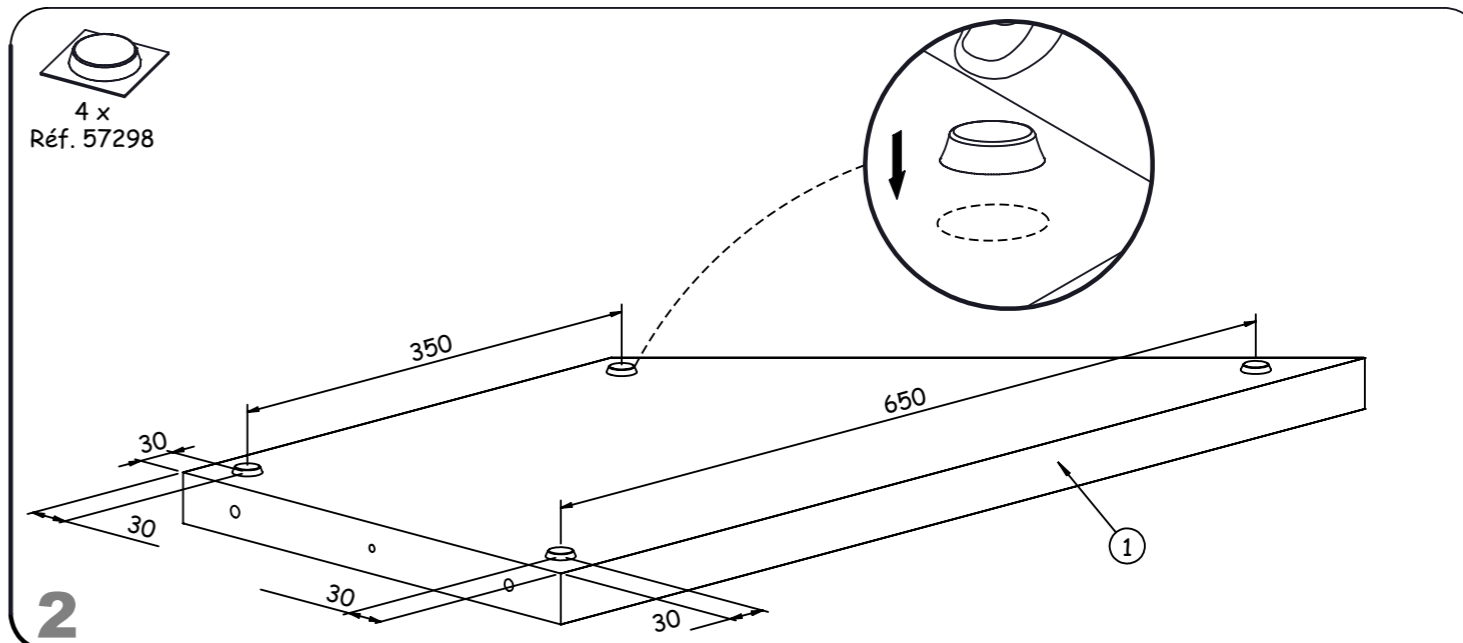
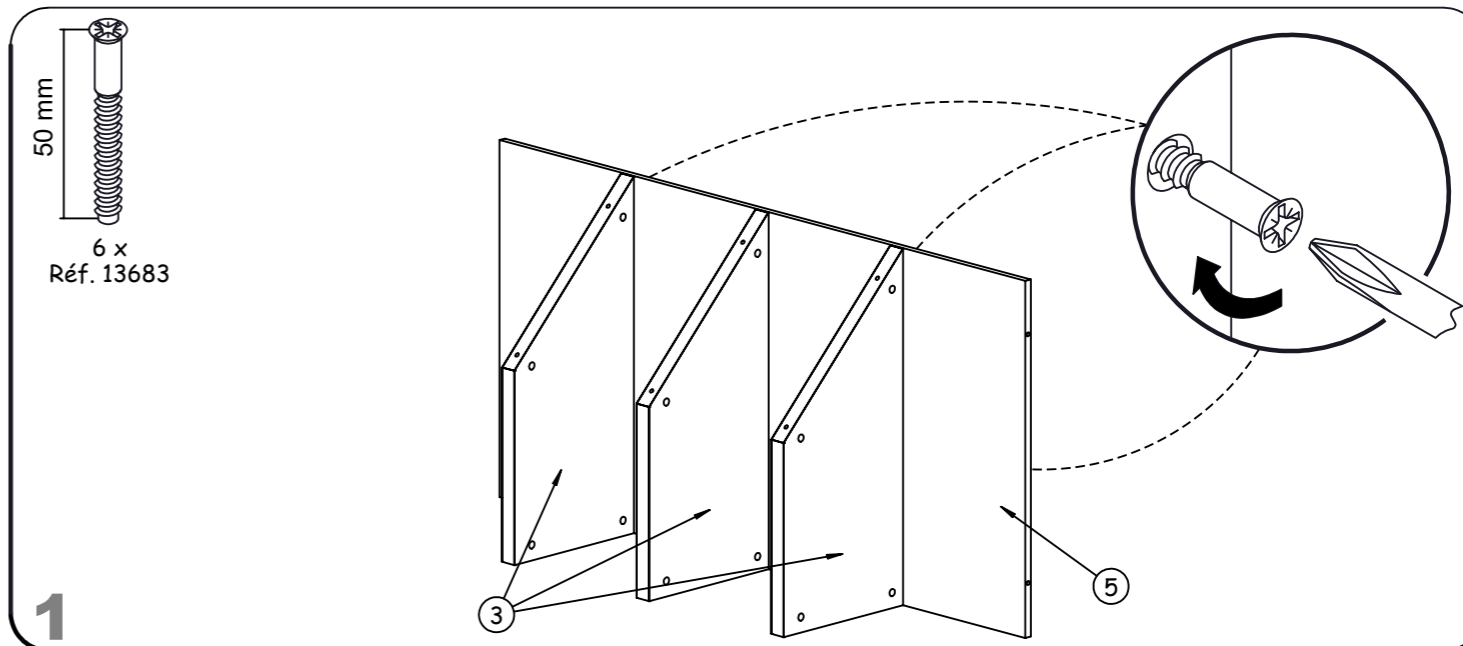
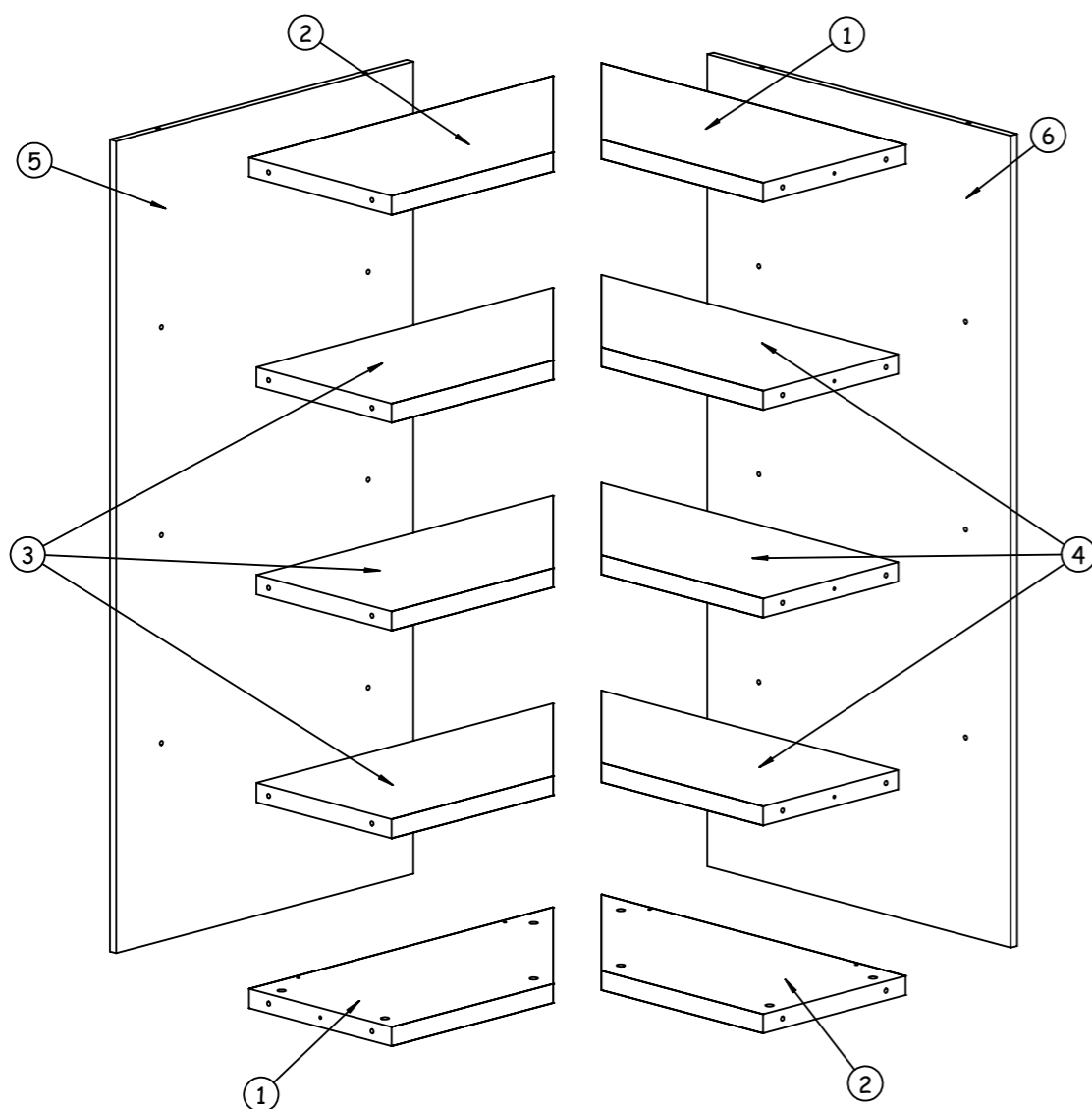

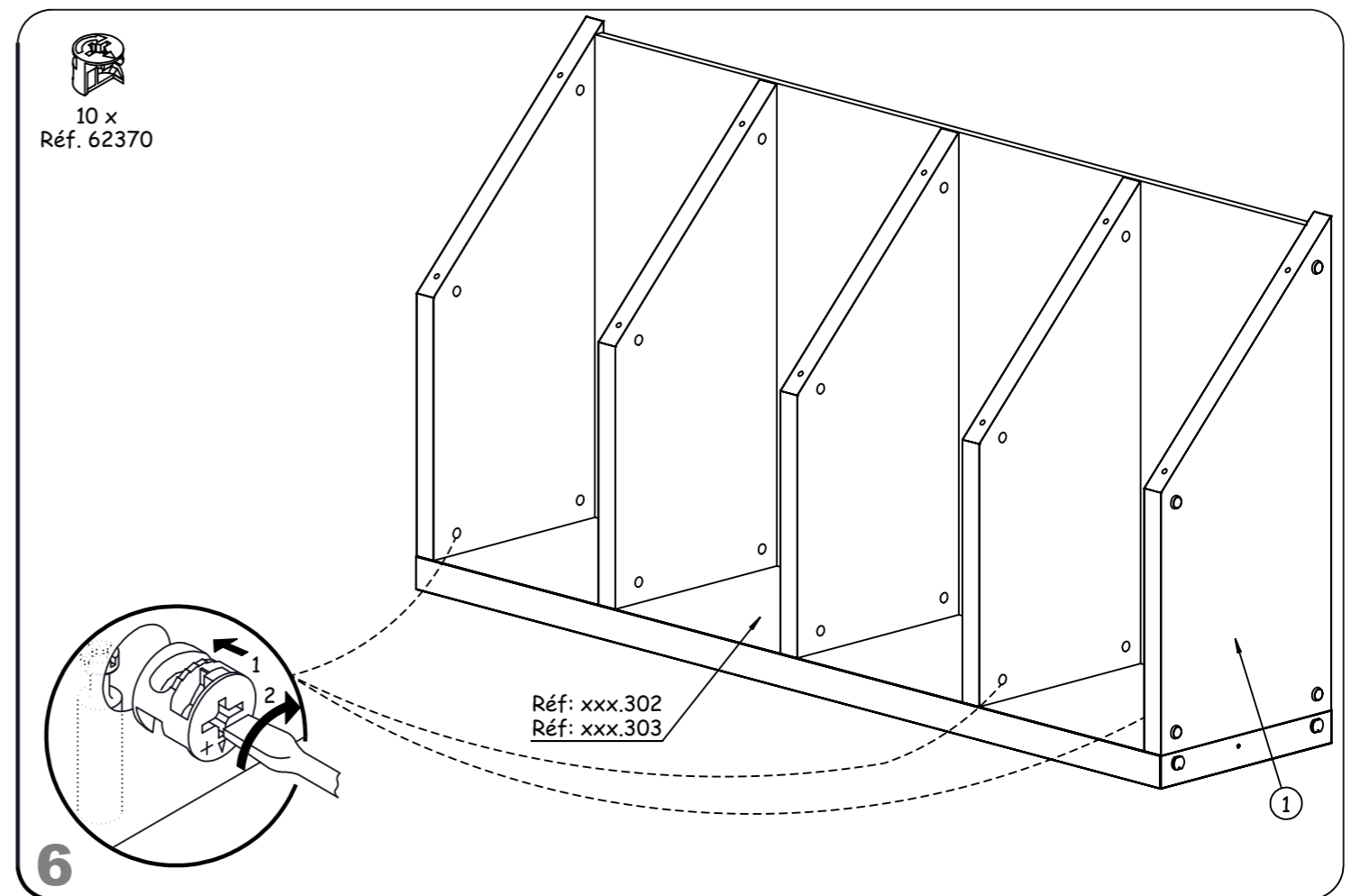
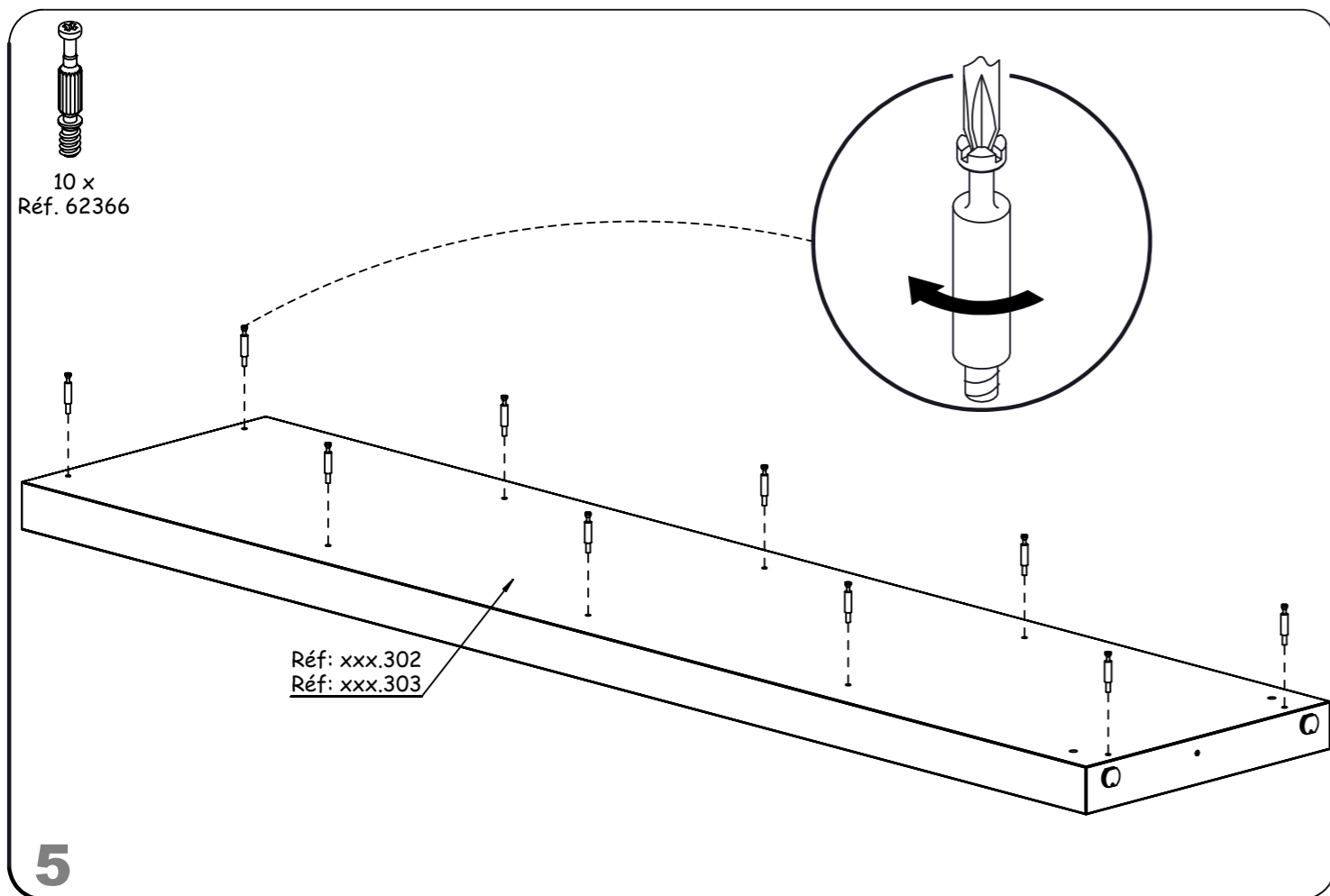
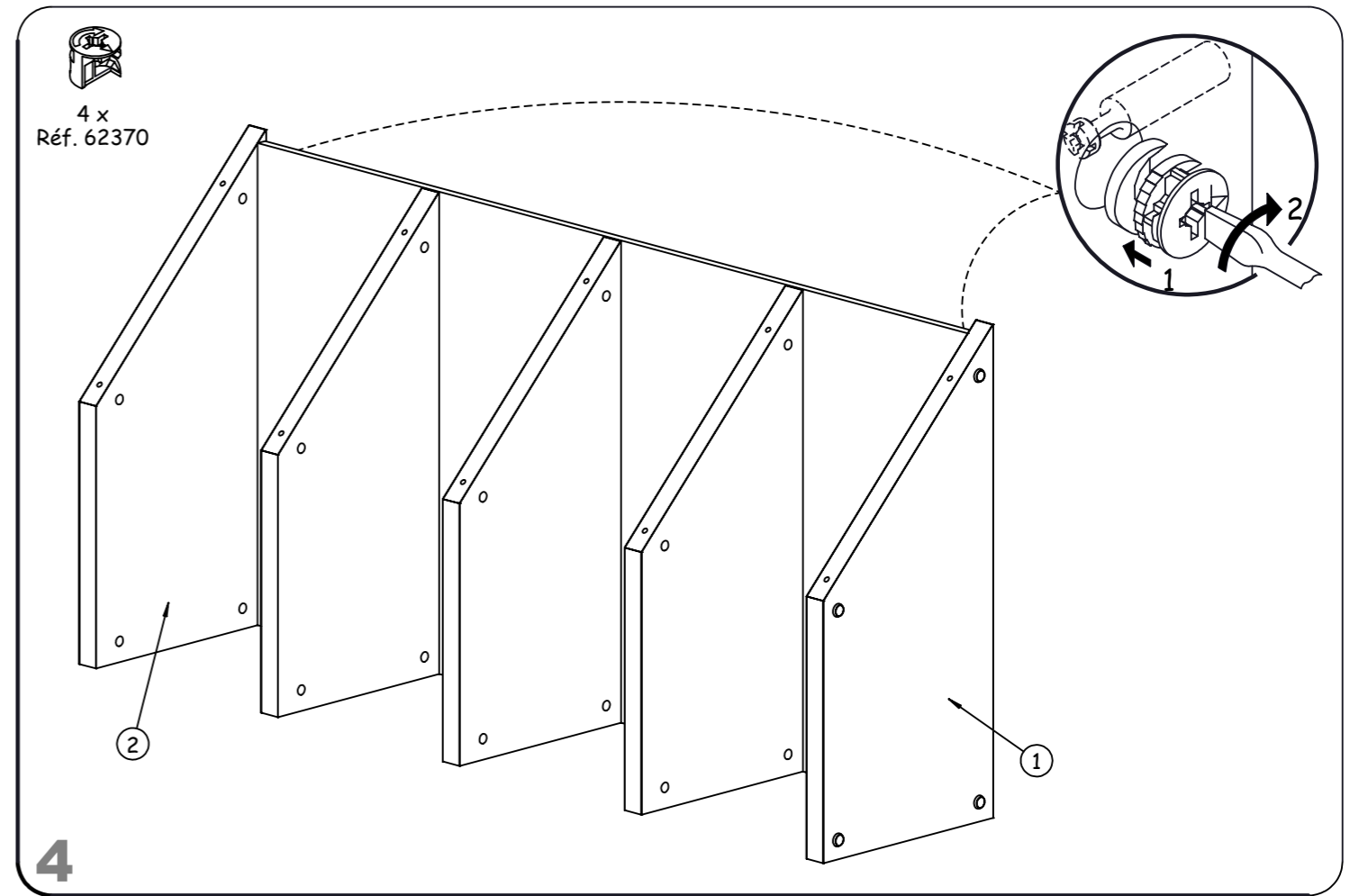
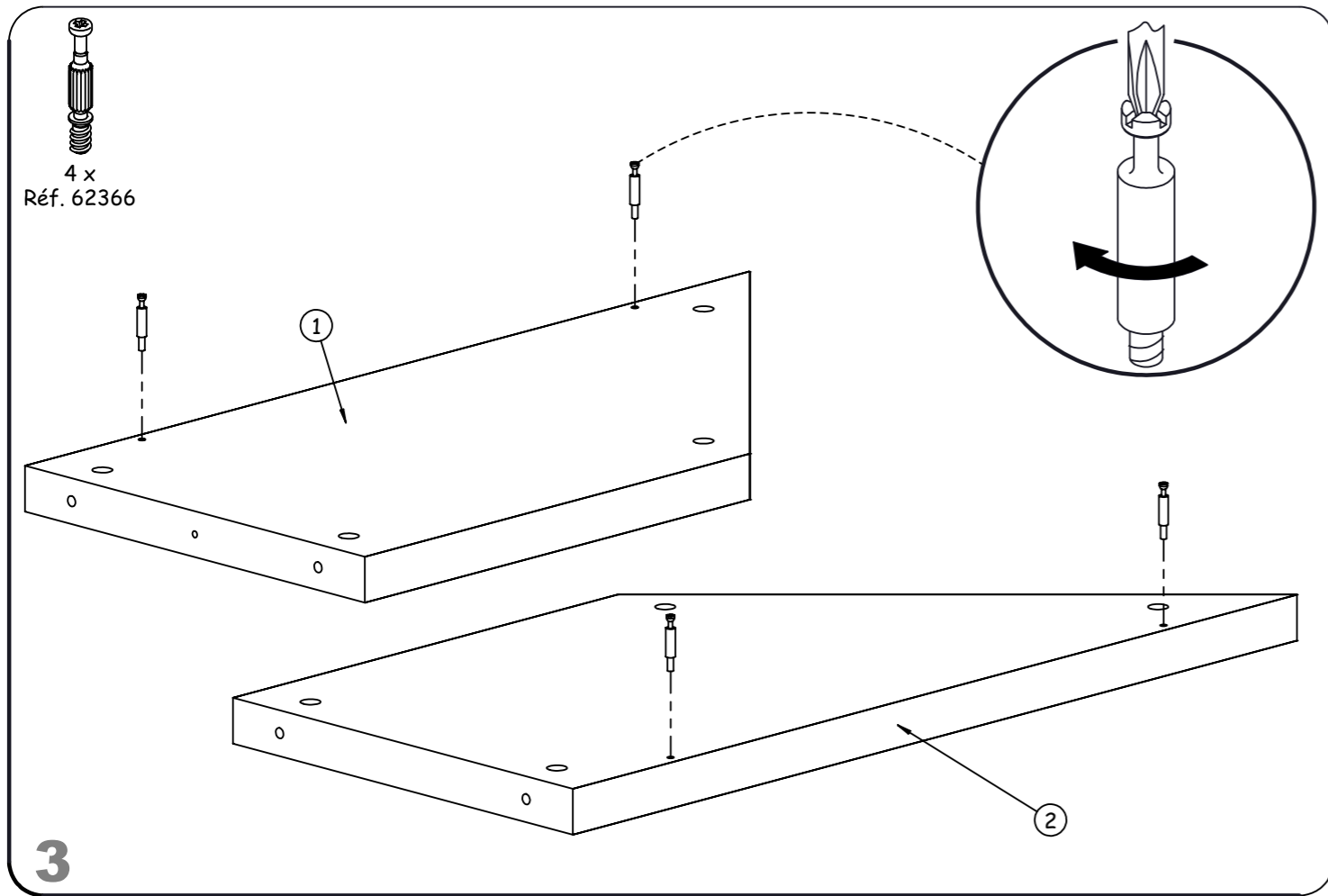

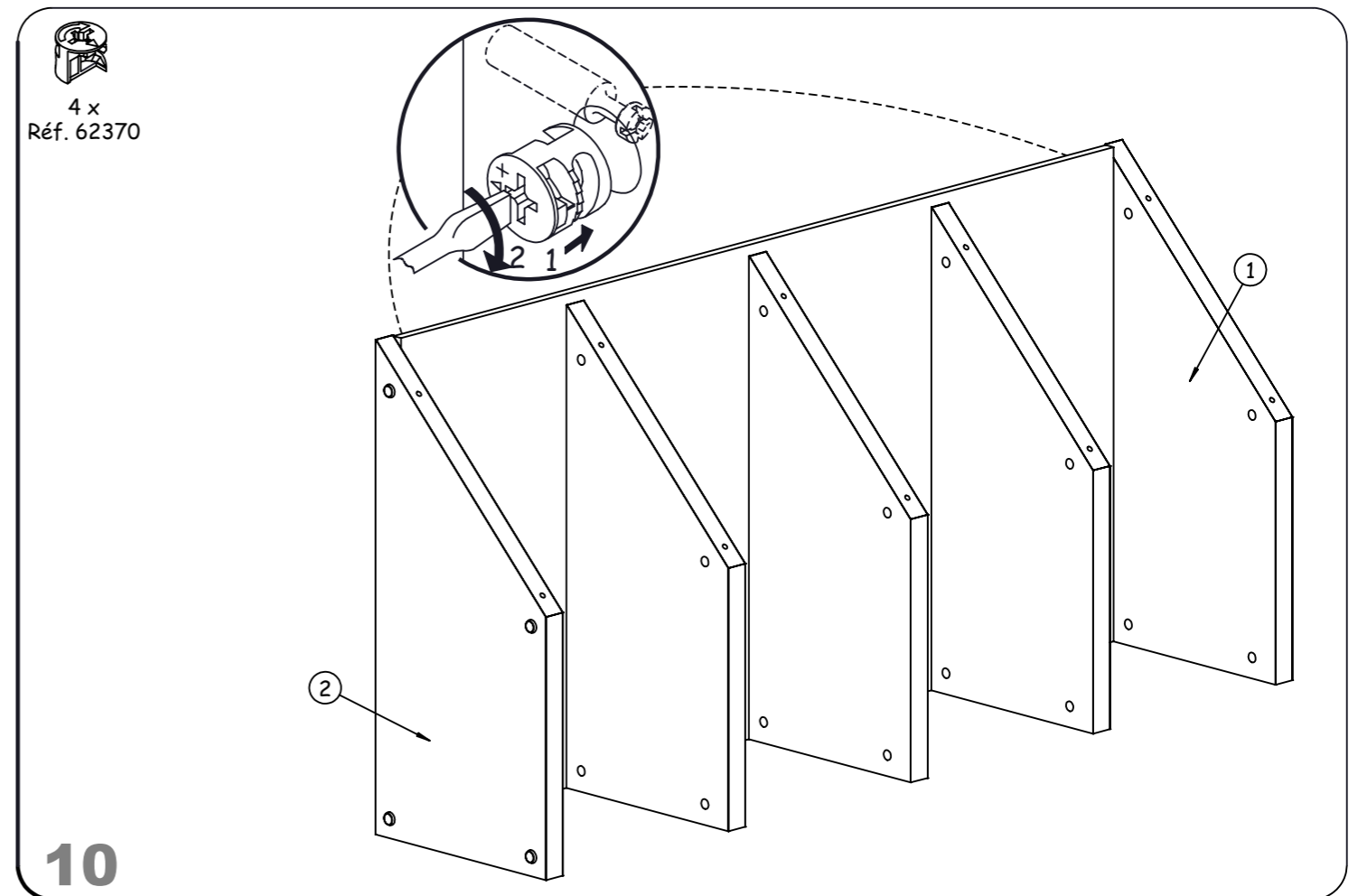
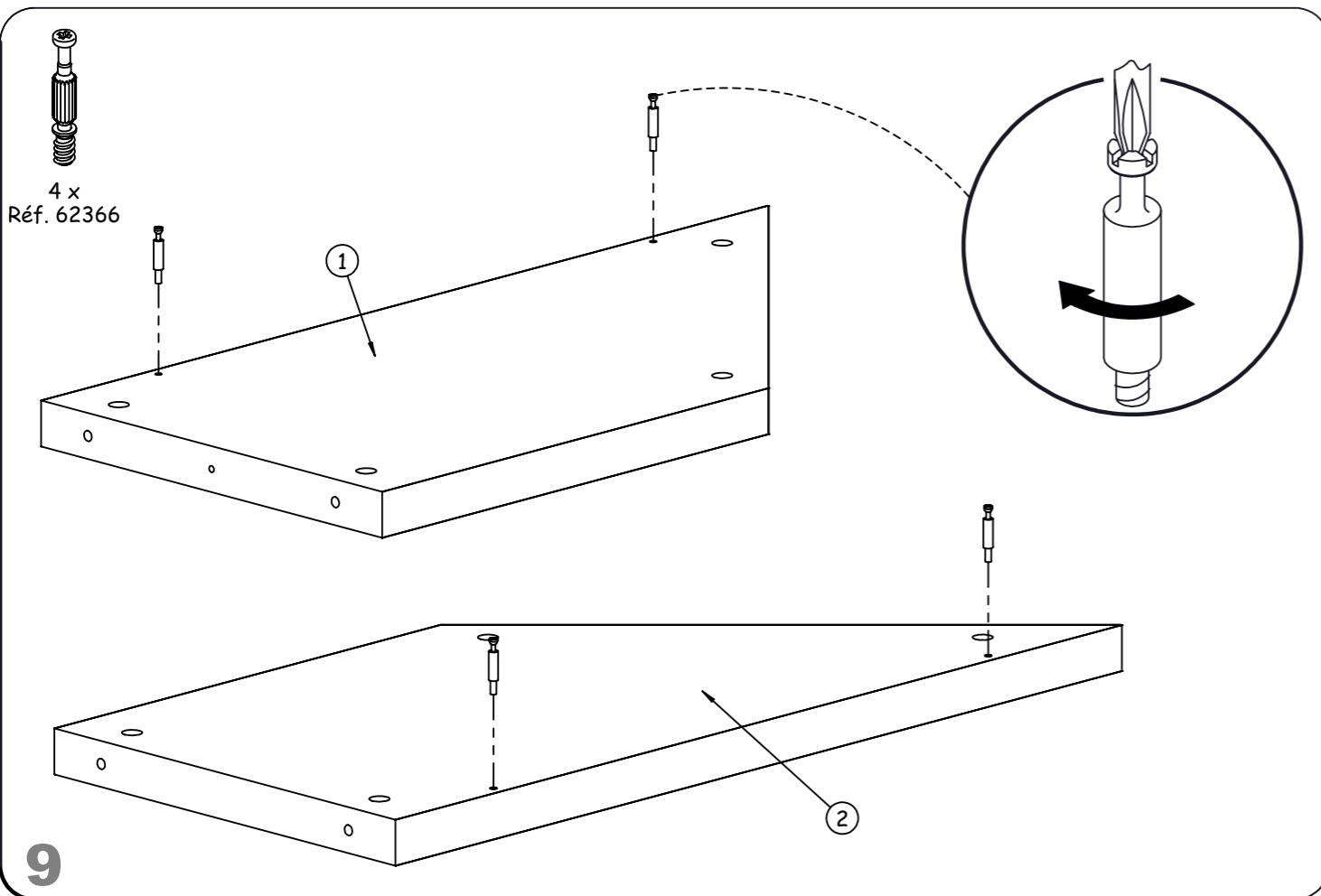
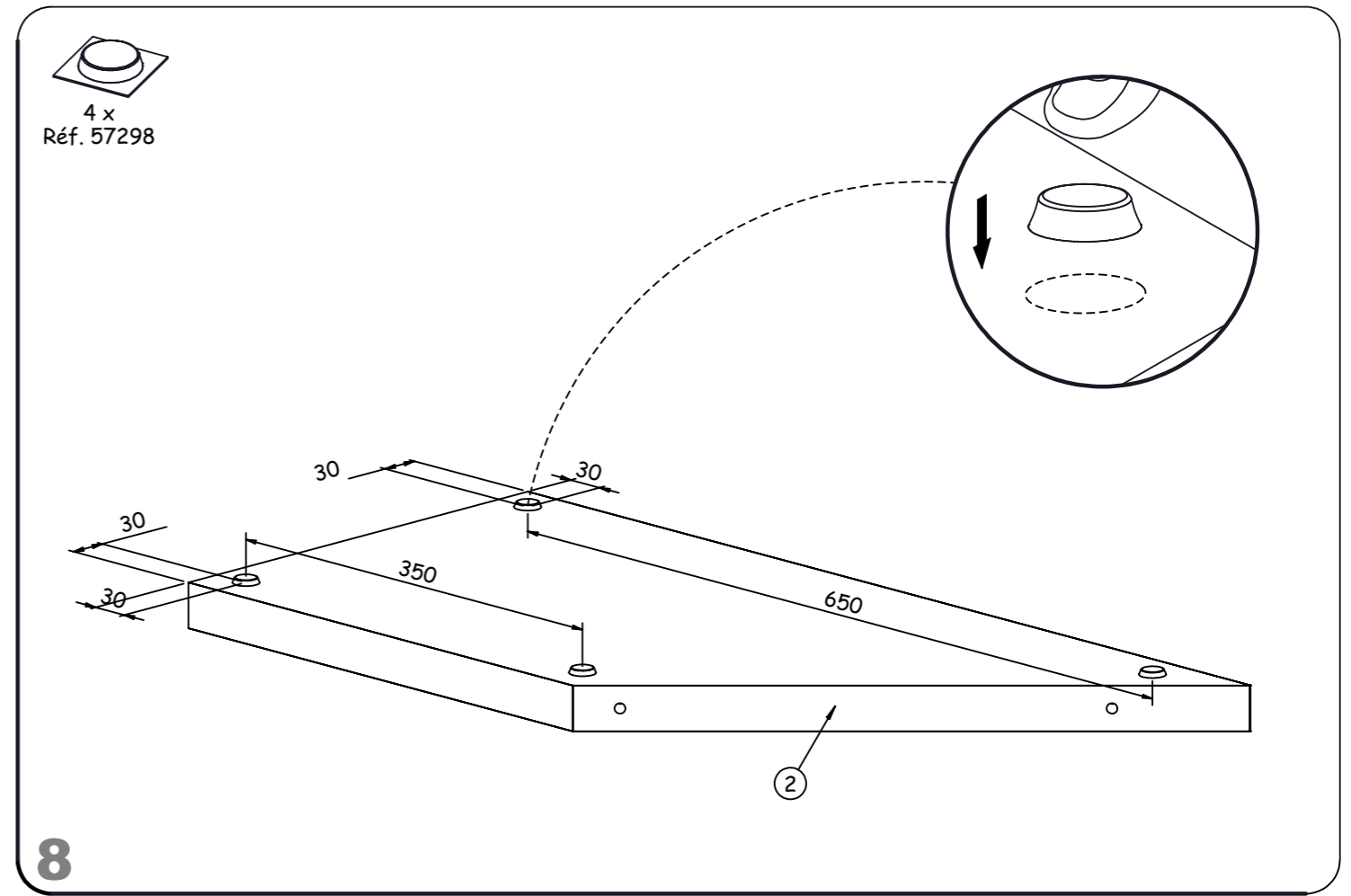
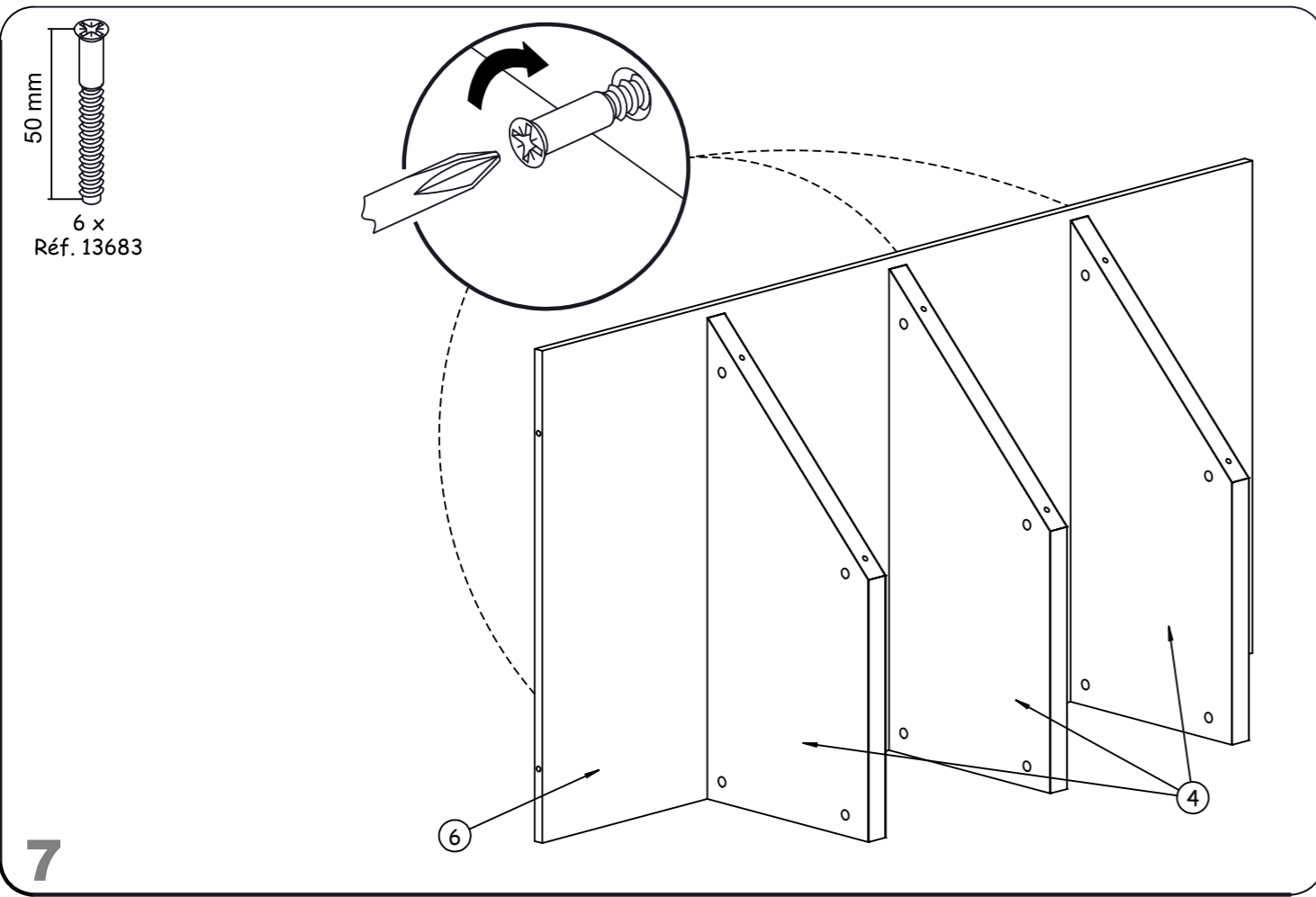

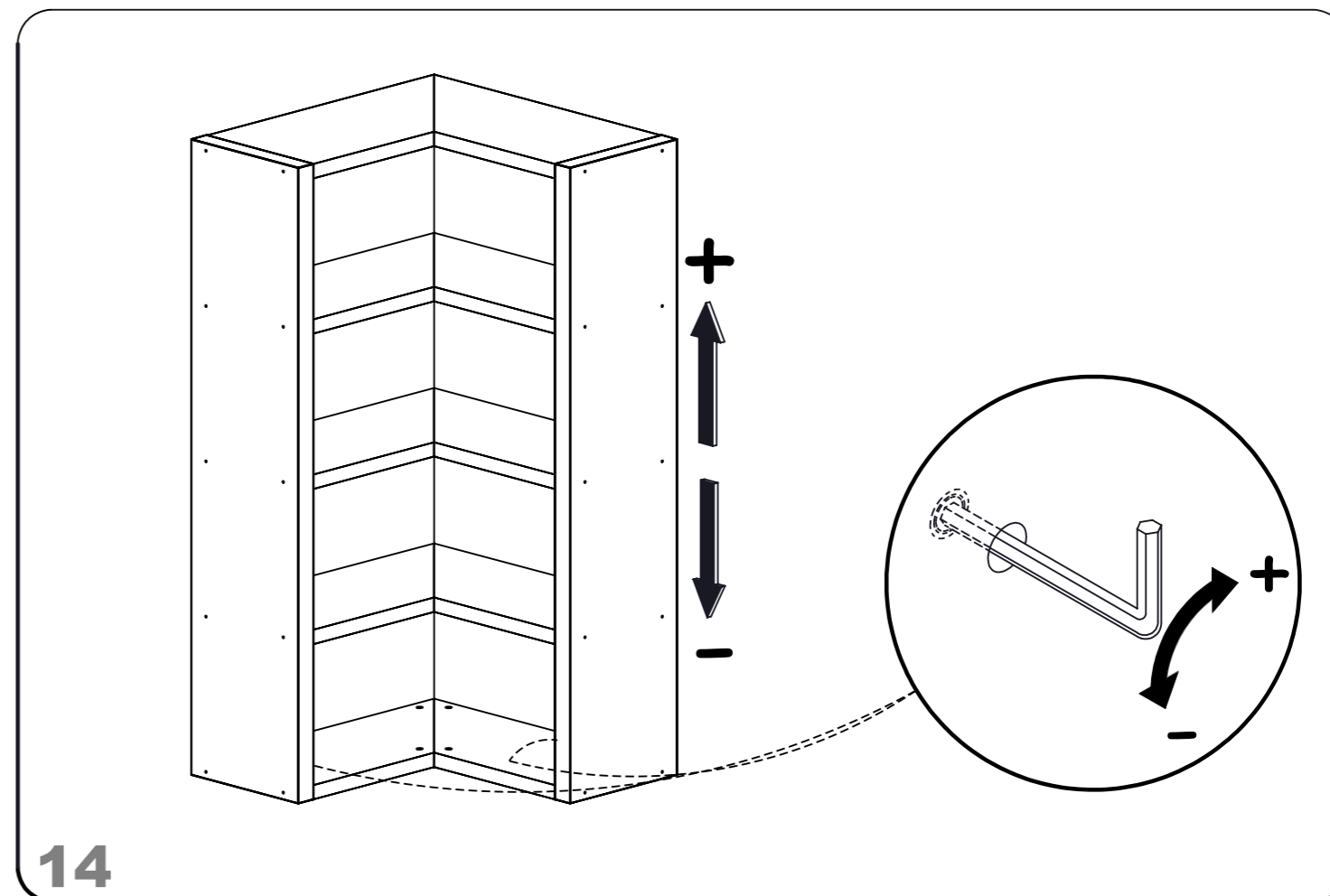
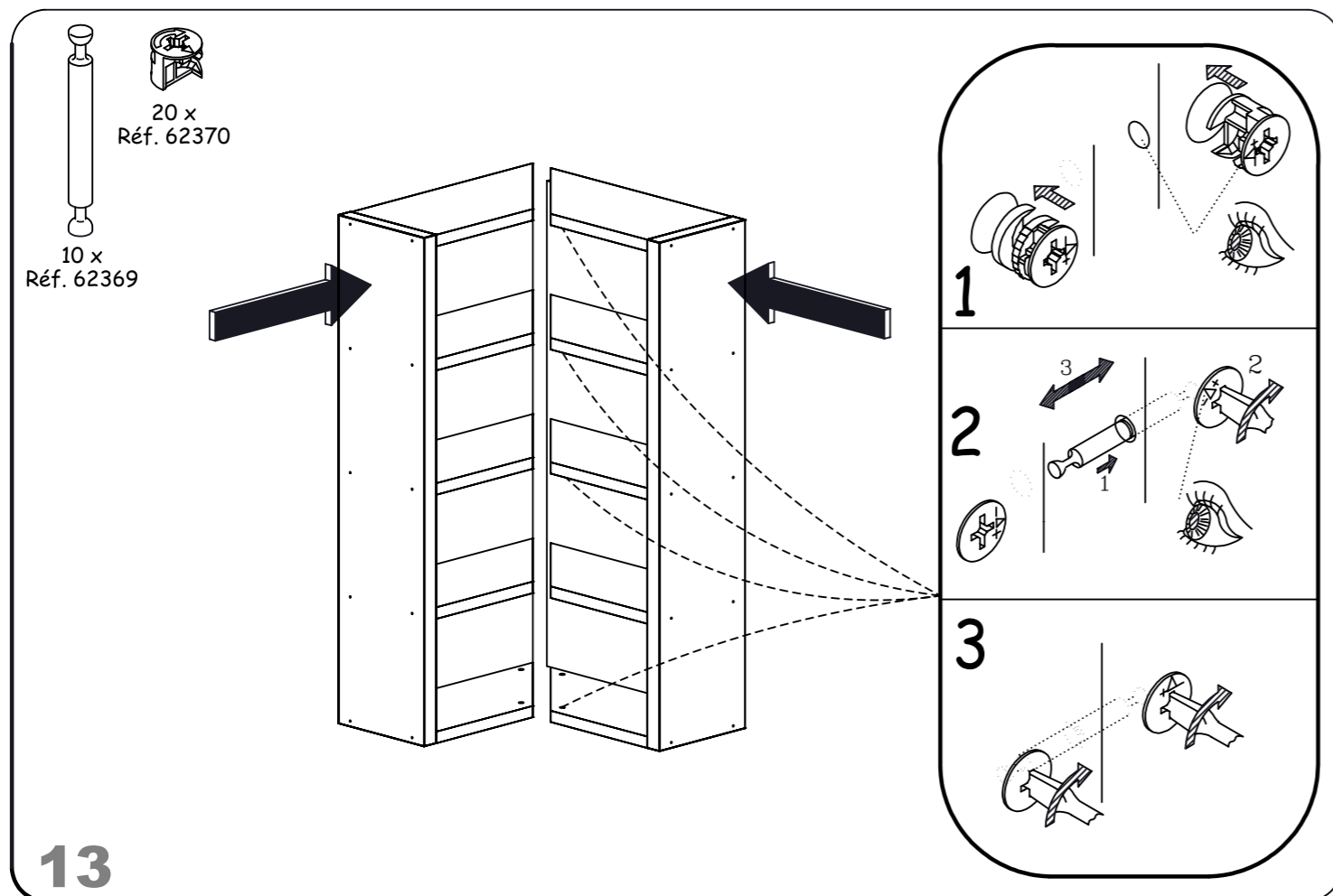
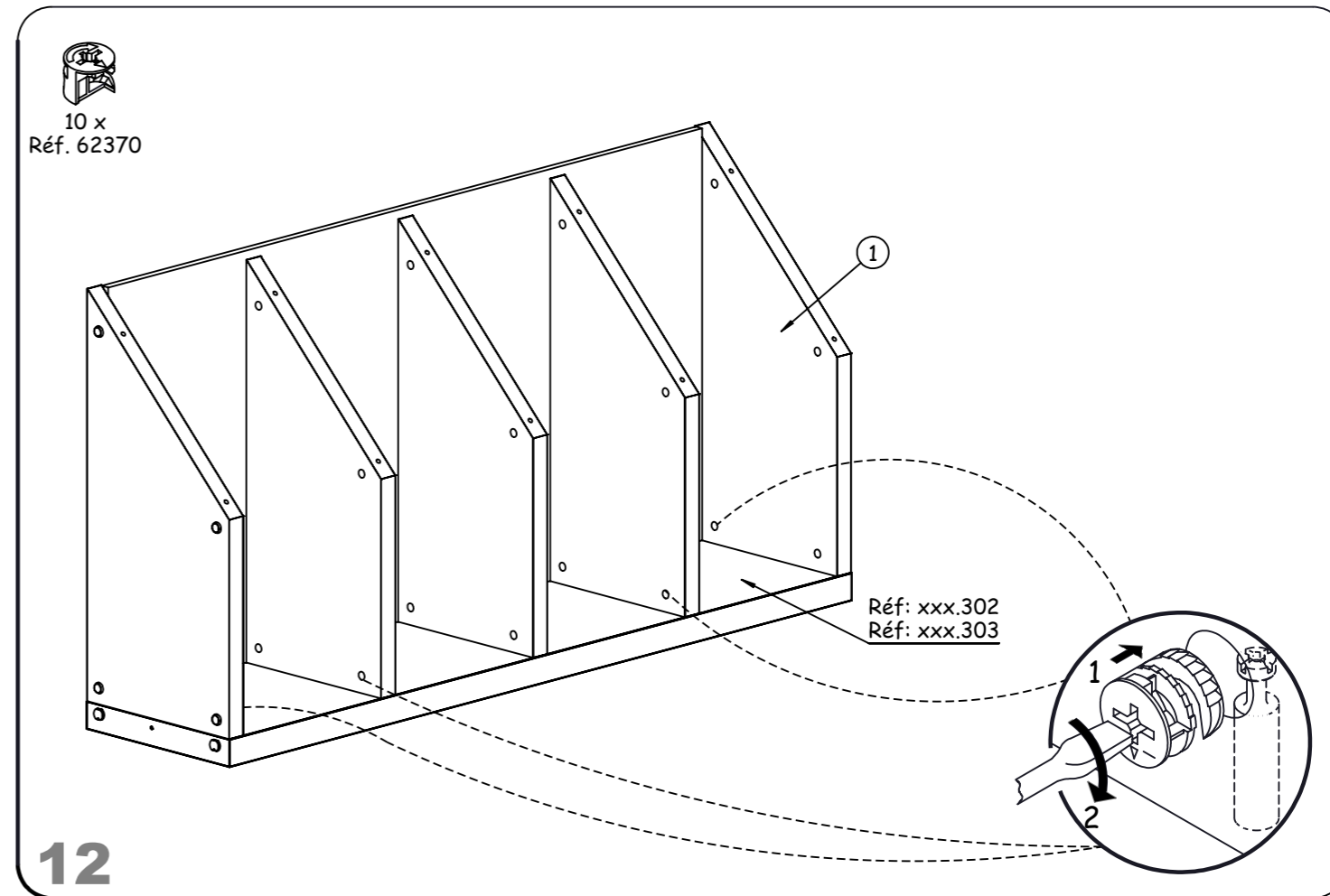
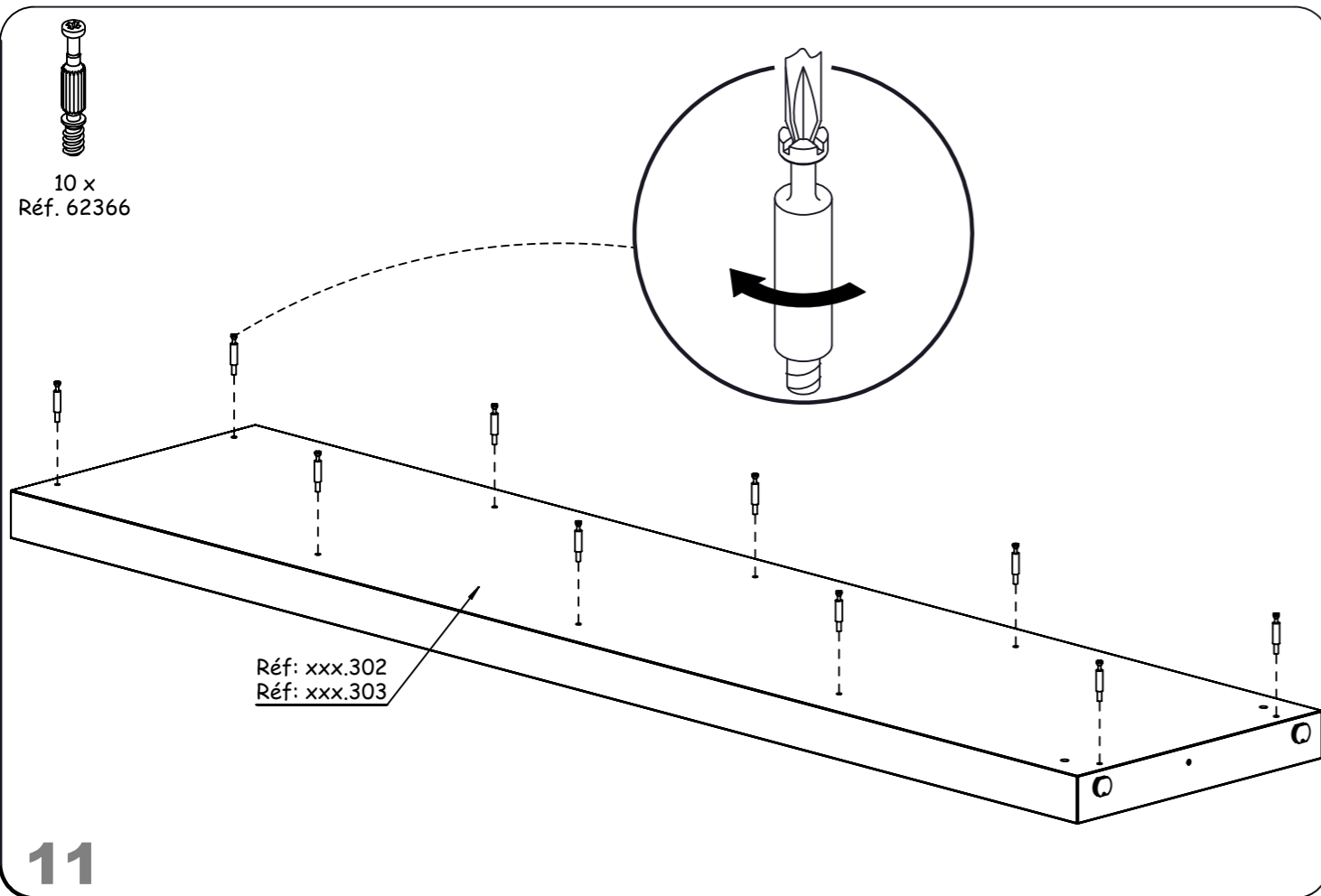



15



 40 x Réf. 37426 (D11)

8 x Réf. 59595 (D12)
 8 x Réf. 59593 (D13)
 8 x Réf. 59589 (D15)
 8 x Réf. 64311 (D18)
 8 x Réf. 64314 (D19)



 4 x Réf. 7017 (D11)

3 x Réf. 59594 (D12)
 3 x Réf. 59592 (D13)
 3 x Réf. 59588 (D15)
 3 x Réf. 64452 (D18)
 3 x Réf. 64581 (D19)

16

 8 x Réf. 28620 (D11)

8 x Réf. 59595 (D12)
 8 x Réf. 59593 (D13)
 8 x Réf. 59589 (D15)
 8 x Réf. 64311 (D18)
 8 x Réf. 64314 (D19)

 12 x Réf. 12168 (D11)

3 x Réf. 59594 (D12)
 3 x Réf. 59592 (D13)
 3 x Réf. 59588 (D15)
 3 x Réf. 64452 (D18)
 3 x Réf. 64581 (D19)

**INSTRUCTIONS DE RECYCLAGE - RECYCLING INSTRUCTIONS - INSTRUCCIONES DE RECICLAJE
 RECYCLING INSTRUCTIES - RECYCLING-ANWEISUNGEN - ISTRUZIONI DI RICICLAGGIO
 ИНСТРУКЦИЯ ПО УТИЛИЗАЦИИ - GERİ DÖNÜŞÜM TALİMATLARI**

FR Lors de l'élimination de votre mobilier usagé, les composants en bois, en plastique et en métal peuvent être séparés et être dirigés en déchetterie vers les contenants appropriés pour favoriser leur valorisation. Toutefois, n'oubliez pas que vous pourrez prolonger la durée de vie de vos produits usagés en contactant les associations caritatives de votre région.

GB When your furniture is no longer of use, its wood, plastic and metal components can be separated out and placed in the appropriate bins to be recycled. But remember that you may be able to extend the useful life of used furniture by passing it on to a charitable association in your neighbourhood.

ES Cuando elimine su mobiliario usado, los componentes de madera, plástico y metal pueden separarse y llevarse al vertedero y tirarse en los contenedores apropiados para su reciclaje. No obstante, no olvide que podrá prolongar la duración de vida de sus productos usados si se pone en contacto con las asociaciones de voluntariado social de su región.

NL Houten, plastic en metalen onderdelen van uw afgedankte meubels kunt u in gescheiden vorm aanbieden bij een afvalverzamelpunt en in de daarvoor bestemde containers werpen zodat ze opnieuw gebruikt kunnen worden. U kunt natuurlijk ook nog een tweede leven geven aan uw meubels door contact op te nemen met een liefdadigheidsinstelling bij u in de buurt.

DE Die Holz-, Kunststoff und Metallteile Ihrer Altmöbel können getrennt und in einem Wertstoffhof dem entsprechenden Recycling zugeführt werden. Ihre Altmöbel können jedoch auch für andere noch nützlich sein - wenden Sie sich an karitative Vereine in Ihrer Umgebung-Wohnregion.

IT Al momento dell'eliminazione del vostro mobile usato, i componenti in legno, in plastica ed in metallo possono essere separati ed essere portati in discarica verso i contenitori idonei per favorire la loro valorizzazione. Tuttavia, non dimenticate che potreste prolungare la durata di vita dei vostri prodotti usati contattando le associazioni caritative della vostra regione.

RU Для того, чтобы избавиться от старой мебели, можно рассортировать детали из дерева, пластика и металла и отправить в пункты сбора утиля для их переработки и вторичного использования. Однако, не забывайте, что вы можете продлить срок службы изделий, связавшись с благотворительными организациями вашего региона.

TR Eski mobilyanızı elden çıkarırken, ahşap, plastik ve metal bileşenler ayrıştırılabilir ve özel bir atık boşaltma yerinde tekrar değerlendirilmelerine katkıda bulunmak için uygun konteynirlara bırakılabilir. Ancak unutmayınız ki bölgenizdeki hayır kurumlarıyla irtibata geçerek eskimiş ürünlerinizin ömrünü uzatabilirsiniz.

Merci de garder ce document pendant toute la vie du produit. vous pouvez le coller comme indiqué ci-contre.
Please conserve this document all along the product life. You can stick it as noticed on the picture.

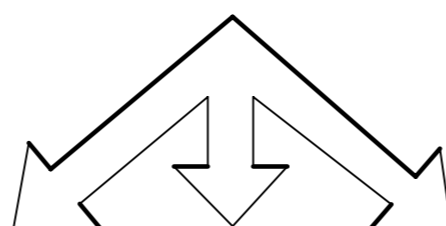
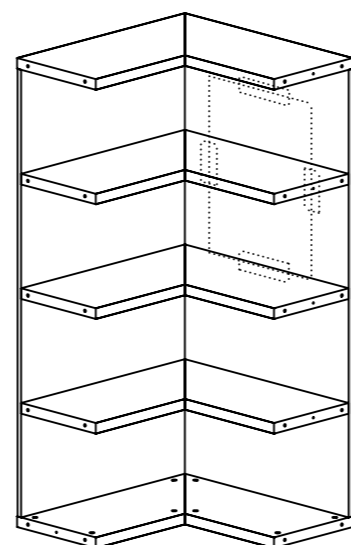

- Veiller à prendre des précautions lors de la séparation verre et panneau.
 - TAKE CARE when separating glass and panel.
 - Les rogamos que sean extremadamente cuidadosos cuando separen el cristal y el tablero
 - Gelieve de nodige voorzogsmaatregelen te nemen bij het scheiden van glas en paneel
 - Bei der Trennung von Glas und Spanplatten, bitte mit größter Vorsicht vorgehen.
 - Favorite prestare particolare attenzione al momento della separazione del vetro e dei pannelli.
 - Будьте осторожны при извлечении стекла из панели!
 - Panel ve camı ayırdiginizda dikkatli olun

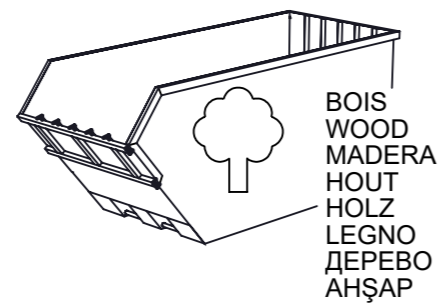
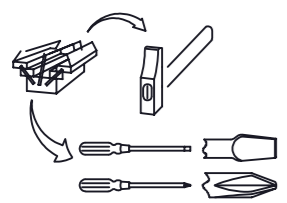

BOIS
WOOD
MADERA
HOUT
HOLZ
LEGNO
ДЕРЕВО
AHŞAP

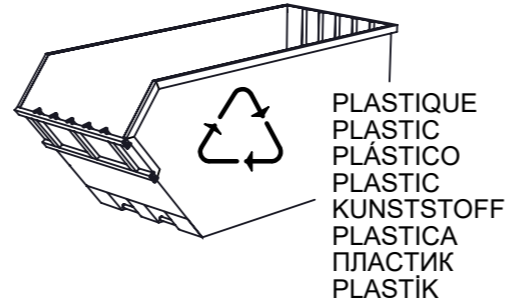

PLASTIQUE
PLASTIC
PLÁSTICO
PLASTIC
KUNSTSTOFF
PLASTICA
ПЛАСТИК
PLASTİK

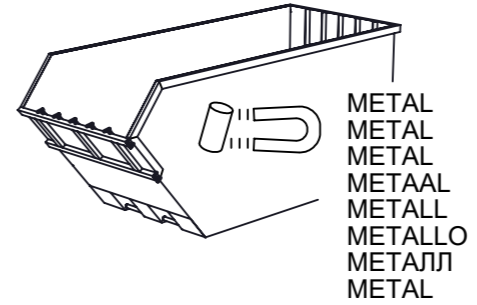

METAL
METAL
METAL
METAAL
METALL
METALLO
МЕТАЛЛ
METAL

CONSEILS D'ENTRETIEN :

MELAMINES, LAQUES ET VERNIS SE NETTOIENT EXCLUSIVEMENT A L'AIDE D'EAU SAVONNEUSE.

HINTS ON CARE :

MELAMINE, ENAMELS AND VARNISHES ARE EXCLUSIVELY CLEANED WITH SUDSY WATER.

CONSEJOS PARA EL CUIDADO :

MELAMINA, LACADOS Y BARNIZADOS SE LIMPIAN EXCLUSIVAMENTE CON AGUA ENJABONADA.

ONDERHOUD :

VOOR LAK EN VERNIS ALLEEN MAAR EEN LICHT SOP GEBRUIKEN.

PFLEGEVORSCHRIFTEN :

MELAMINBESCHICHTUNGEN, LACKE UND FIRNISSE SIND NUR MITTELS SEIFENWASSER ZU REINIGEN.

MANUTENZIONE :

MELAMINATO, LACCHE E VERNICI SI PULISCONO ESCLUSIVAMENTE E SOLO CON ACQUA E SAPONE.

СОВЕТЫ ПО УХОДУ ЗА МЕБЕЛЬЮ:

ПОКРЫТИЯ ИЗ МЕЛАМИНА, ЭМАЛИ ИЛИ ЛАКА МОЖНО ЧИСТИТЬ ТОЛЬКО МЫЛЬНОЙ ВОДОЙ.

BAKÝM İÇİN İPUCU :

MELAMINE,BAŞKÝ VE CILALÝ YÜZEYLERİ TEMİZLER İKEN SADECE ARÝ SU KULLANÝNÝZ.

GARANTIE :

SI VOUS CONSTATEZ UNE EVENTUELLE ANOMALIE, PRECISEZ LA NATURE DU DEFAUT SUR CETTE FICHE ET RETOURNEZ-LA AU MAGASIN QUI VOUS A VENDU LE MEUBLE. CE DOCUMENT NOUS SERA IMMEDIATEMENT TRANSMIS.

GARANTY :

IN THE UNLIKELY EVENT OF THERE BEING A MANUFACTURING OR MATERIAL DEFECT, PLEASE CONTACT THE RETAILER FROM WHOM YOU PURCHASED OUR FURNITURE WITHOUT DELAY. STEPS WILL THEN BE TAKEN TO EFFECT EARLY REMEDIAL ACTION.

GARANTIA :

SI USTED OBSERVA ALGUNA EVENTUAL ANOMALIA, EXPLIQUE LA NATURALEZA DEL DEFECTO Y DEVUELVA LA FICHA A LA TIENDA DONDE HA COMPRADO EL MUEBLE, QUE NOS LO HARA SEGUIR.

WAARBORG :

GELIEVE DE BIJHORENDE GARANTIEKAART MET EVENTUELE AARD EN OORZAAK VAN BESCHADIGINGEN NAAR UW WINKELIER TERUG TE STUREN, DIE ZE ONS ZAL DOORSUREN.

GARANTIE :

SOLLTEN SIE EVENTUELL EINEN MANGEL FESTSTELLEN SO BITTEN WIR SIE, UNS DIESEN NACHSTEHEND ZU BESCHREIBEN UND DIESES BLATT IHREM LIEFERANTIEN ZUZUSENDEN.

GARANZIA :

SE TROVATE QUALCHE DISCREPANZA, SI PREGA DI SPECIFICARE LA NATURA DEL DIFETTO SU QUESTO MODULO E CONSEGNARLO AL NEGOZIO DOVE AVETE ACQUISTATO I MOBILI. QUESTO DOCUMENTO CI SARÀ TRASMESSO IMMEDIATAMENTE.

ГАРАНТИЯ :

Если вы вдруг обнаружили дефекты материала или производства, точно опишите дефект на этом листе и обратитесь в магазин, в котором вы купили мебель. этот документ будет немедленно нам передан и нами рассмотрен.

GARANTI :

ÝSTENMEYEN MALZEME VE/VEYA ÜRETİM HATALARÝ İLE KARŞILAŞTÝĐYNYZDA LÜTFEN ÜRÜNÜ SATÝN ALDÝĐYNYZ BAYII İLE TEMAS KURUNUZ.BU SİZE EN HYZLY ÇÖZÜMÜ GETİRECEKTİR.

NOM / NAME: _____ ADRESSE / ADDRESS: _____

NATURE DU DEFAUT EVENTUEL / NATURE OF THE DEFECT IF ANY : _____

**ORDRE DE DEBALLAGE DES COLIS
UNPACKING ORDER OF THE PARCELS
DESEMBALAR LOS BULTOS EN ESTE ORDEN
VOLGORDE VAN UITPAKKEN VAN DE KOLLIS
REIHENFOLGE BETREFFEND DAS AUSPACKEN DER KOLLIS
RISPETTARE L'ORDINE CRONOLOGICO PER L'APERTURA DEI PACCHI.
ПОРЯДОК РАСПАКОВКИ ДЕТАЛЕЙ
KOLILERIN AÇYLMA TALIMATY**

NUMERO DE CONTROLE / CONTROL NUMBER :

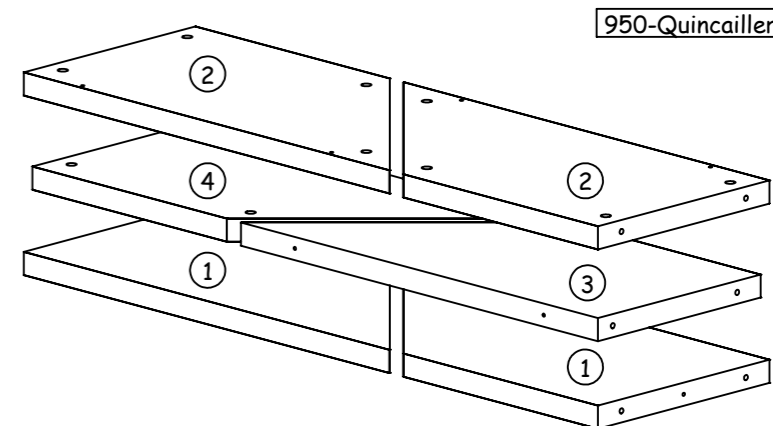
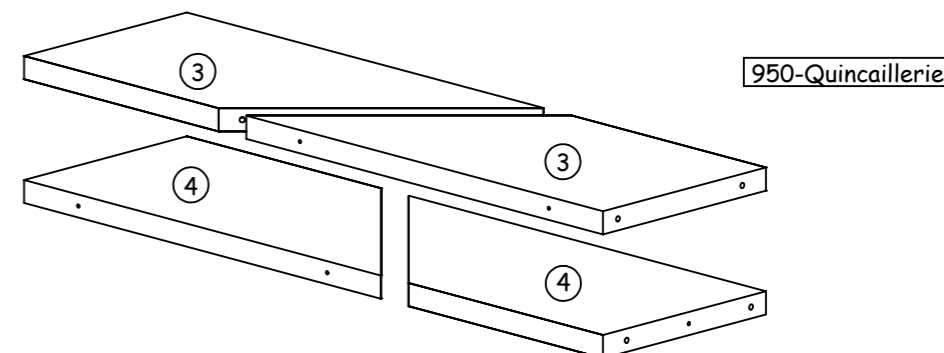
(MERCİ DE COCHER, SUR CETTE FICHE, LE NUMERO DE PIECE ET LA REFERENCE COLIS FAISANT OBJET DE LA RECLAMATION)
(PLEASE CROSS ON THIS FITTING INSTRUCTION THE PIECE NUMBER AND THE PACK REFERENCE CORRESPONDING TO THE PIECE DAMAGED)**COLIS 2**(REF.D11.201)
(REF.D12.201)
(REF.D13.201)
(REF.D14.201)
(REF.D15.201)
(REF.D18.201)
(REF.D19.201)**COLIS 3**(REF.D11.202)
(REF.D12.202)
(REF.D13.202)
(REF.D14.202)
(REF.D15.202)
(REF.D18.202)
(REF.D19.202)**COLIS 1**(REF.D11.204)
(REF.D12.204)
(REF.D13.204)
(REF.D14.204)
(REF.D15.204)
(REF.D18.204)
(REF.D19.204)