

COMMODE  
4 TIROIRS  
REF: 160

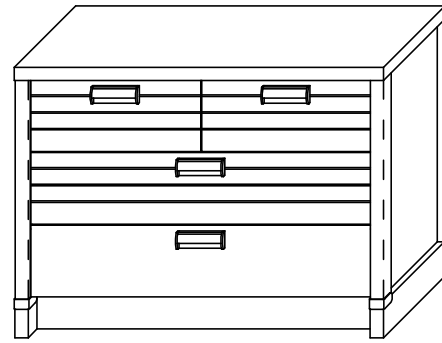

NOTICE DE MONTAGE: Il est très important que vous suiviez phase par phase les instructions de montage !  
 ASSEMBLY INSTRUCTIONS: It is very important that you follow step by step assembly instructions !  
 LAS INSTRUCCIONES: Es muy importante que sigan paso a paso las instrucciones !  
 MONTAGEANLEITUNG: Es ist sehr wichtig, dass Sie die Montageanleitung der Reihe nach verfolgen !  
 MONTAGEPLAN: Het is zeer belangrijk de volgnummers van de handleiding te volgen !  
 ИНСТРУКЦИИ ПО СБОРКЕ: Очень важно шаг за шагом точно следовать инструкции по сборке:

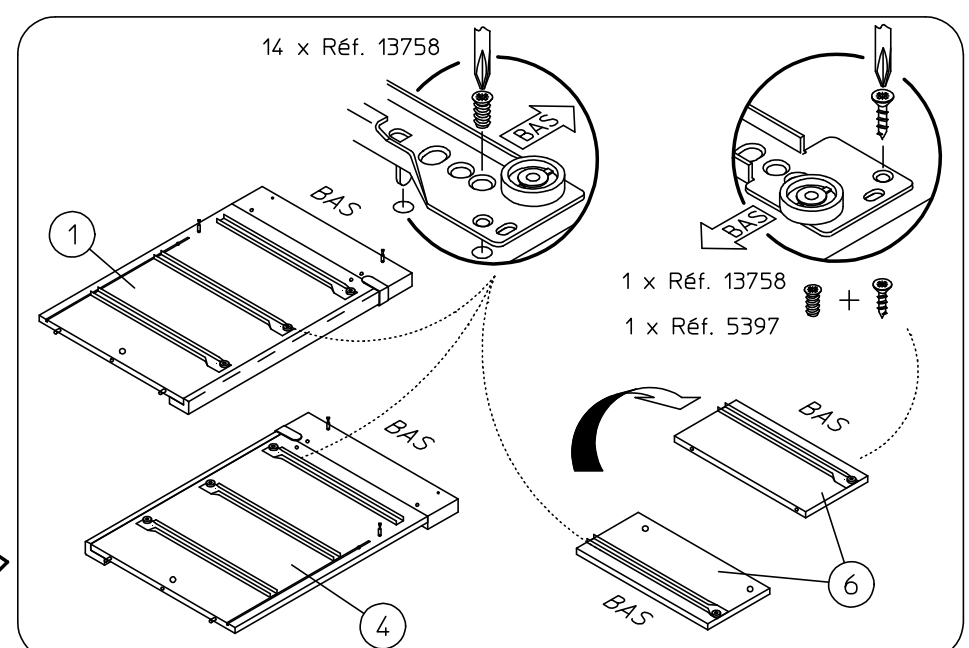

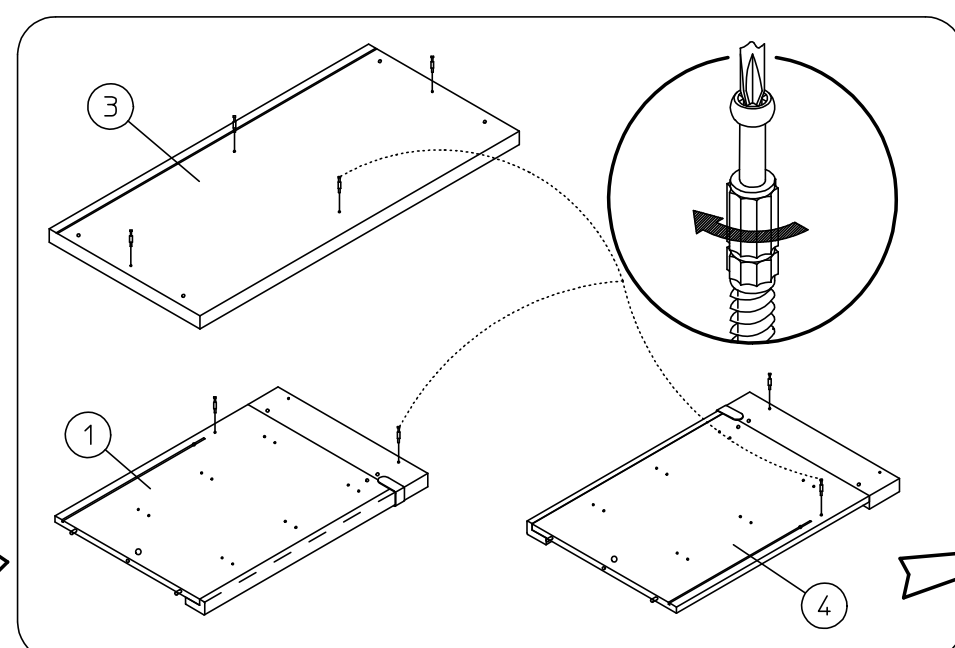
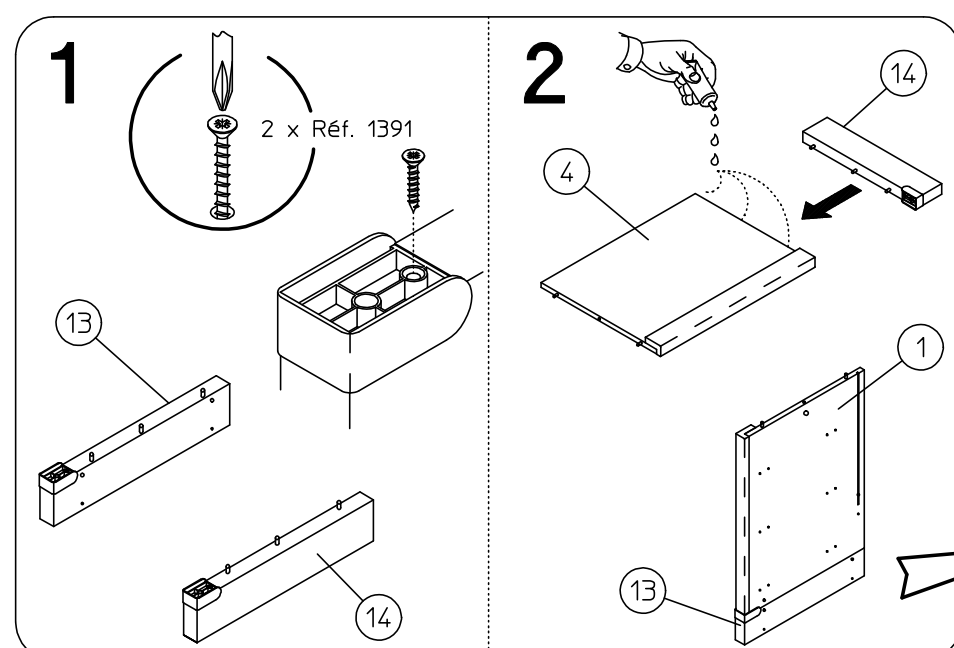
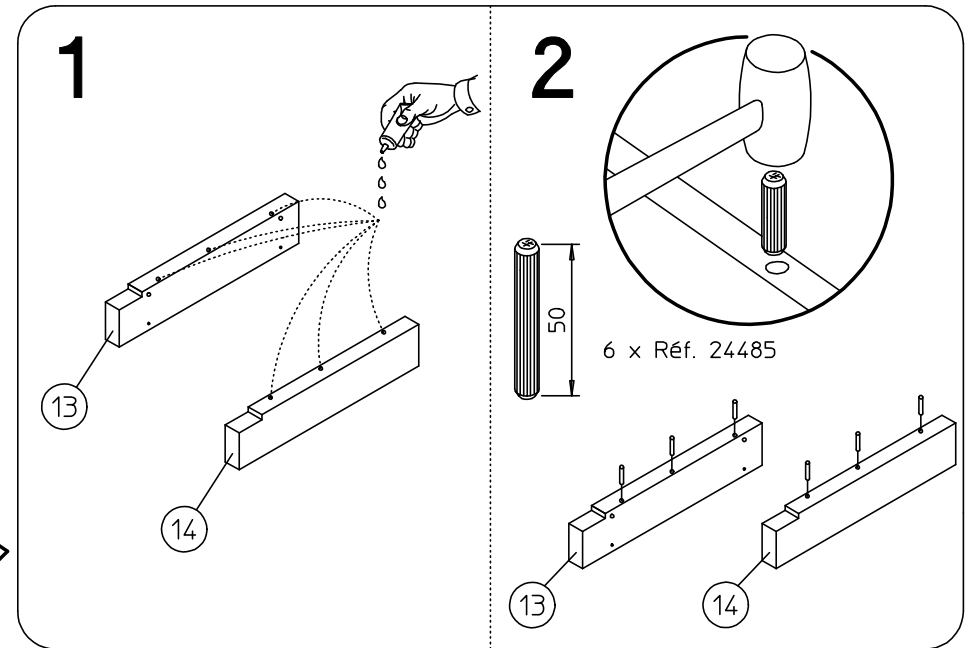
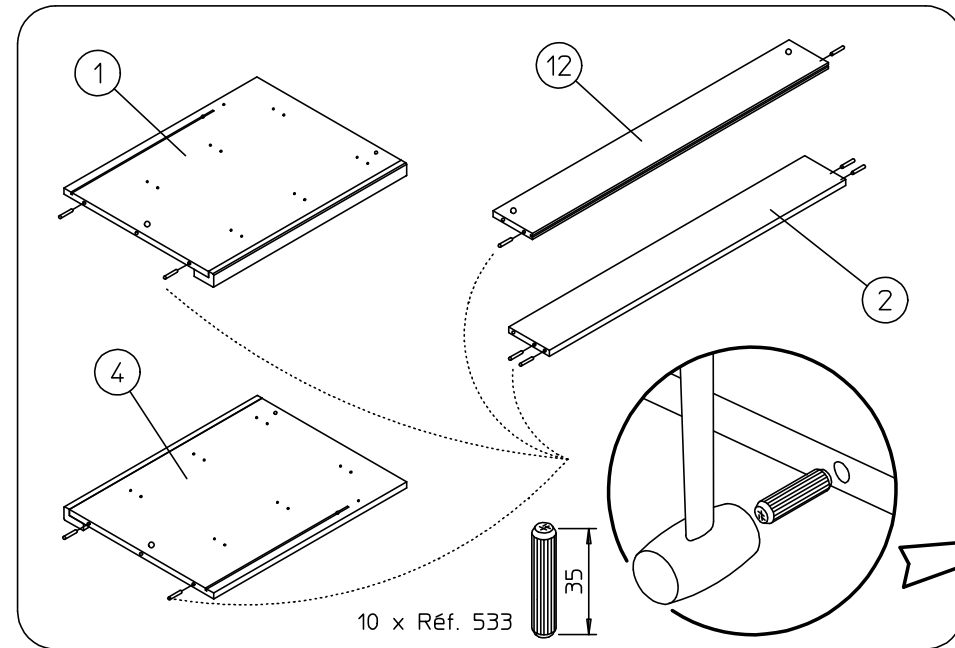
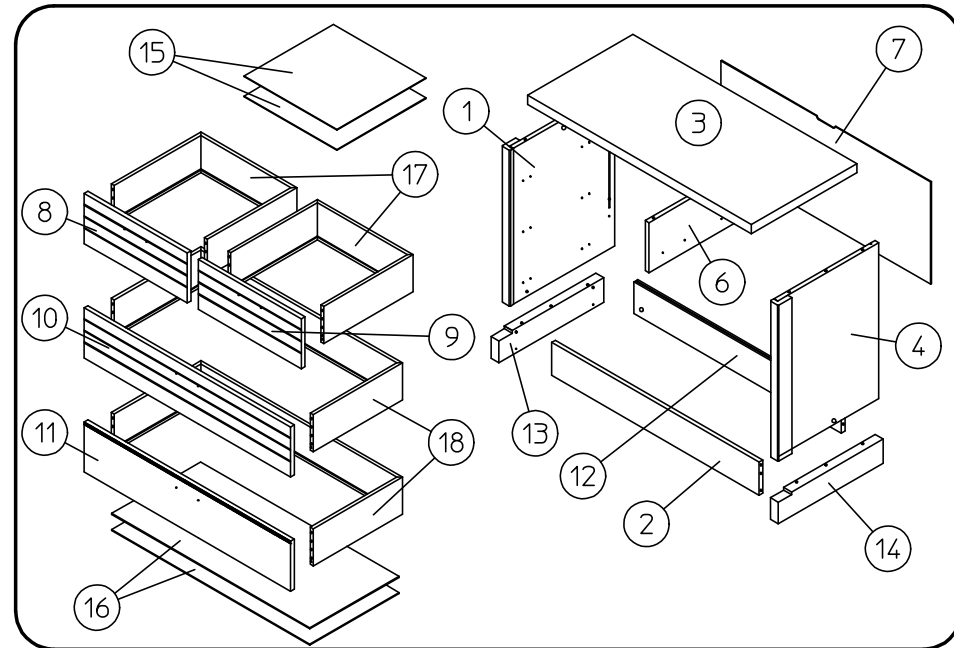
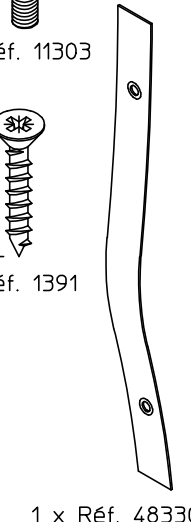
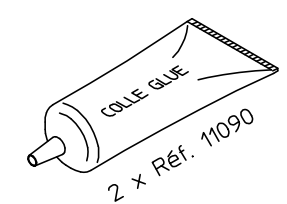
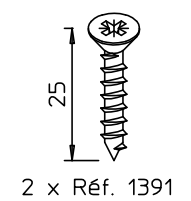
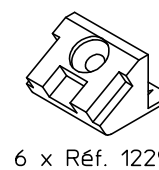
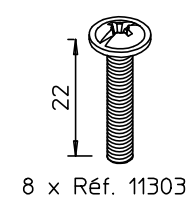
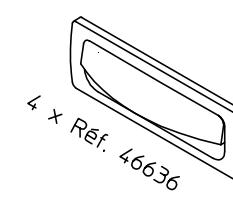
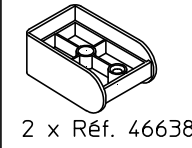
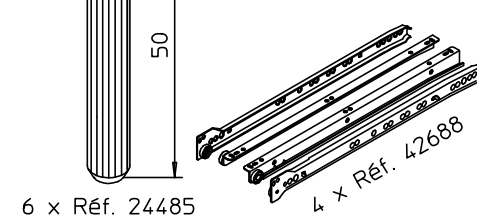
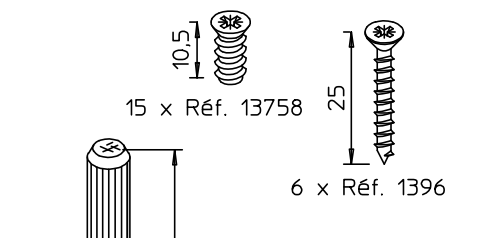
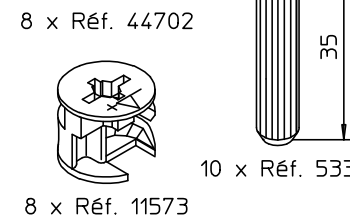
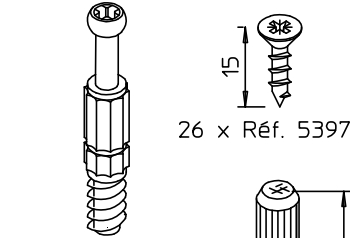
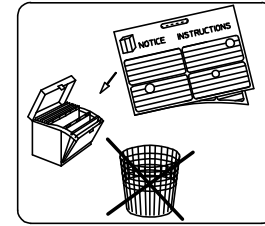
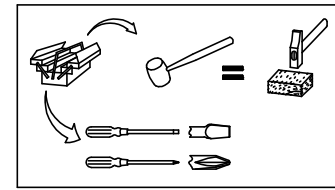
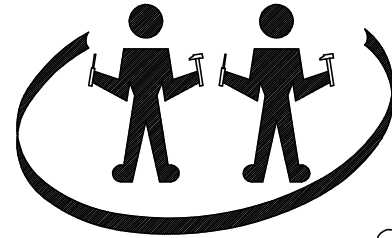
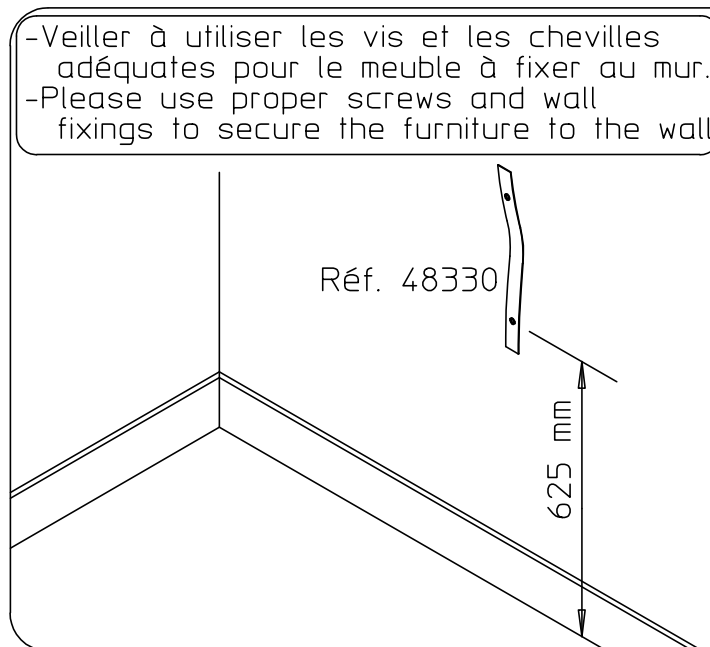
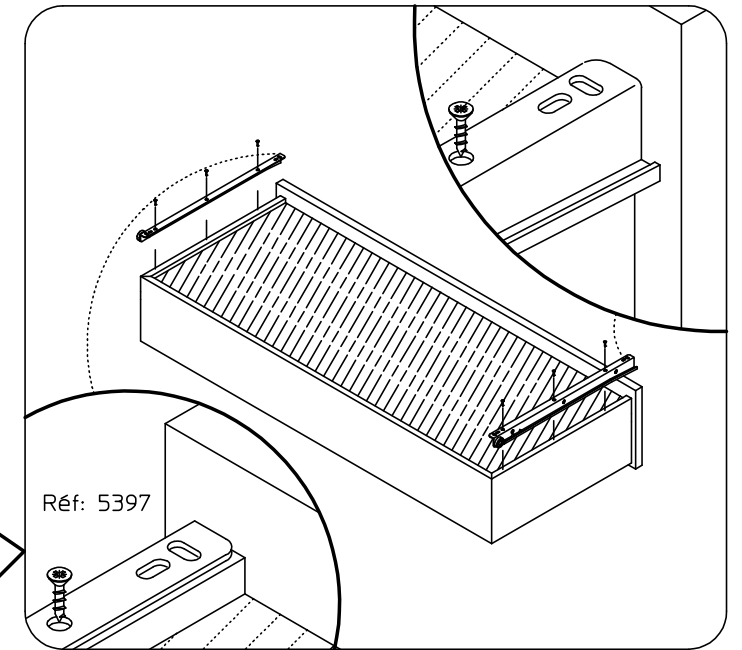
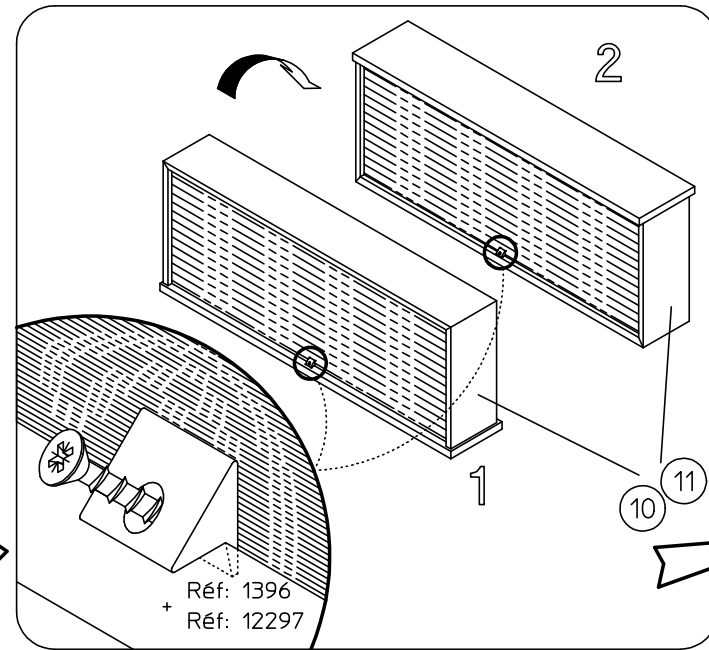
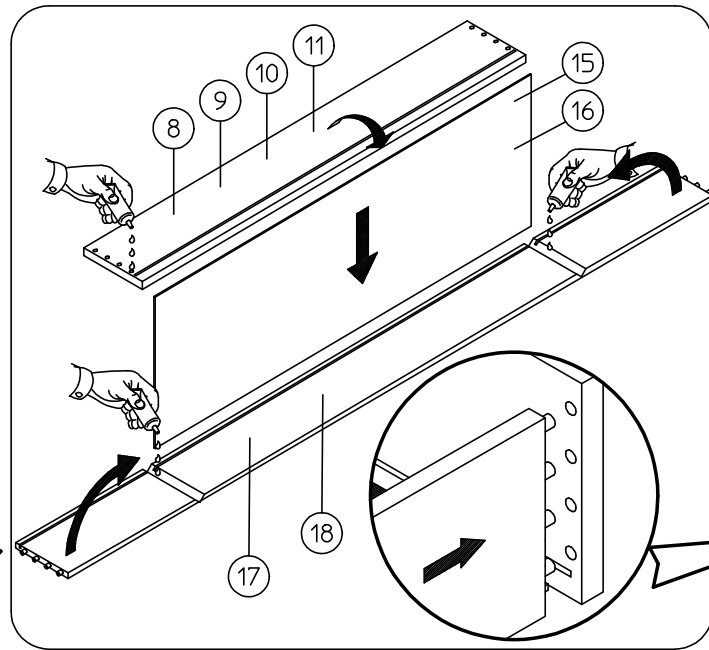
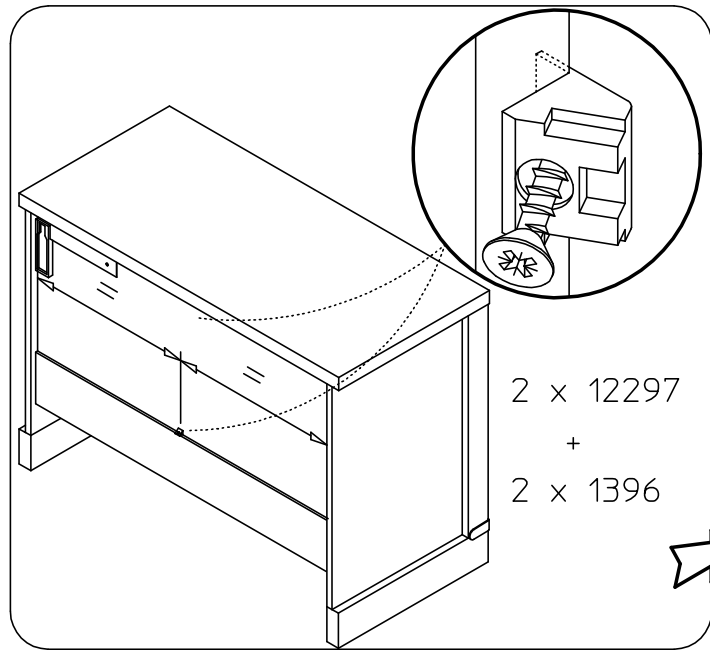
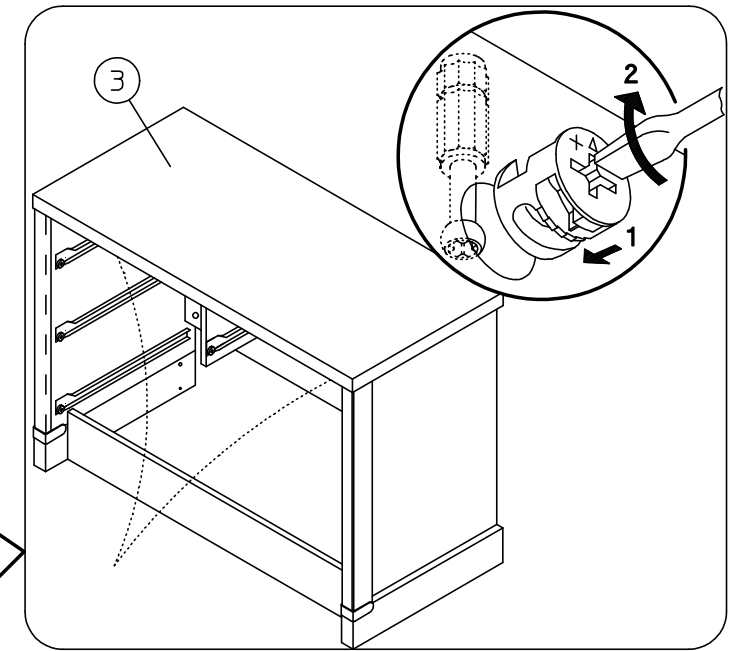
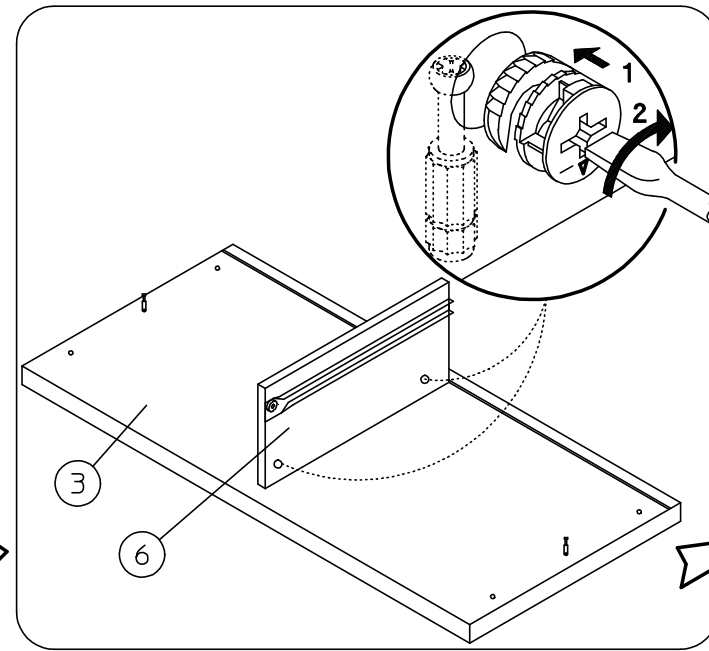
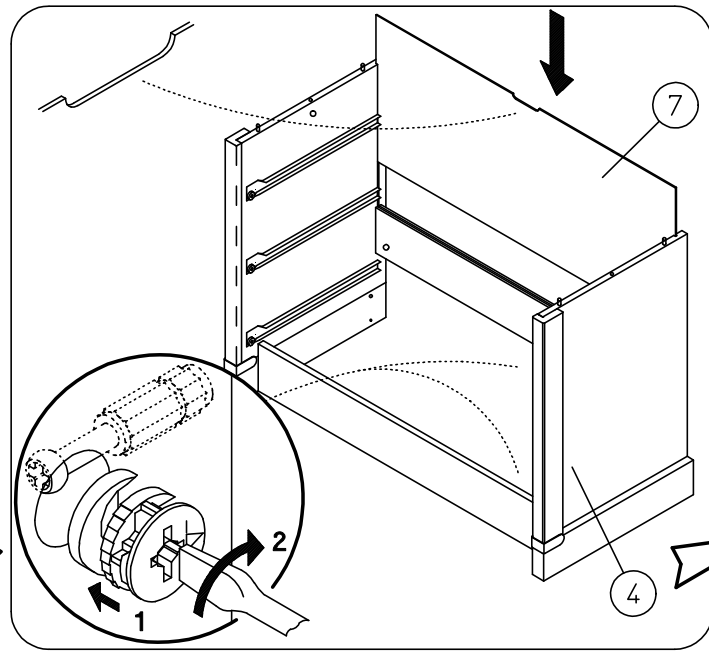
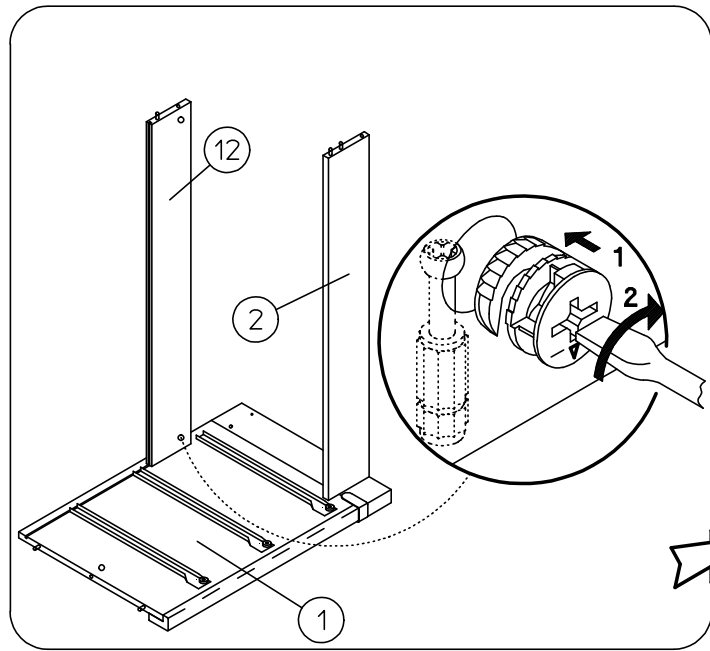

NON INCLUES  
NO INCLUIDOS.  
NOT INCLUDED.  
WERDEN NICHT  
MITGELIEFERT.  
NIET INBEGREPEN.

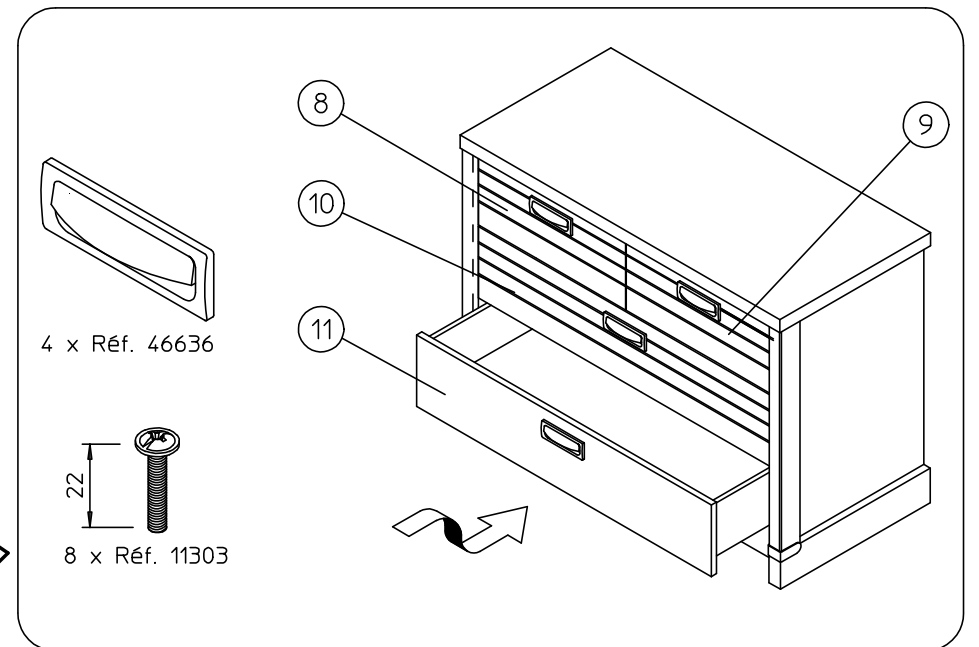
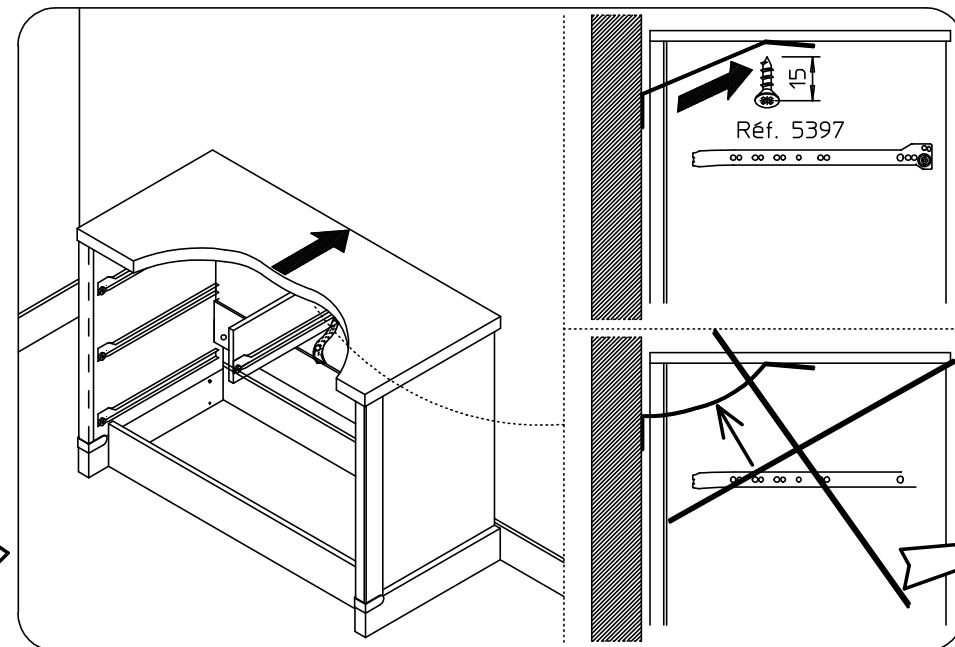

**CONSEILS D'ENTRETIEN :**

MELAMINES, LAQUES ET VERNIS SE NETTOIENT EXCLUSIVEMENT A L'AIDE D'EAU SAVONNEUSE.

**HINTS ON CARE :**

MELAMINE, ENAMELS AND VARNISHES ARE EXCLUSIVELY CLEANED WITH SUDSY WATER.

**PFLEGEVORSCHRIFTEN :**

MELAMINBESCHICHTUNGEN, LACKE UND FIRNISSE SIND NUR MITTELS SEIFENWASSER ZU REINIGEN.

**CONSEJOS PARA EL CUIDADO :**

MELAMINA, LACADOS Y BARNIZADOS SE LIMPIAN EXCLUSIVAMENTE CON AGUA ENJABONADA.

**ONDERHOUD :**

VOOR LAK EN VERNIS ALLEEN MAAR EEN LICHT SOP GEBRUIKEN.

**СОВЕТЫ ПО УХОДУ ЗА МЕБЕЛЬЮ :**

ПОКРЫТИЯ ИЗ МЕЛАМИНА, ЭМАЛИ ИЛИ ЛАКА МОЖНО ЧИСТИТЬ ТОЛЬКО МЫЛЬНОЙ ВОДОЙ.

**GARANTIE :**

SI VOUS CONSTATEZ UNE EVENTUELLE ANOMALIE, PRECISEZ LA NATURE DU DEFAUT SUR CETTE FICHE ET RETOURNEZ-LA AU MAGASIN QUI VOUS A VENDU LE MEUBLE. CE DOCUMENT NOUS SERA IMMEDIATEMENT TRANSMIS.

**GARANTY :**

IN THE UNLIKELY EVENT OF THERE BEING A MANUFACTURING OR MATERIAL DEFECT, PLEASE CONTACT THE RETAILER FROM WHOM YOU PURCHASED OUR FURNITURE WITHOUT DELAY. STEPS WILL THEN BE TAKEN TO EFFECT EARLY REMEDIAL ACTION.

**GARANTIE :**

SOLLTEN SIE EVENTUELL EINEN MANGEL FESTSTELLEN SO BITTEN WIR SIE, UNS DIESEN NACHSTEHEND ZU BESCHREIBEN UND DIESES BLATT IHREM LIEFERANTEN ZUZUSENDEN.

**GARANTIA :**

SI USTED OBSERVA ALGUNA EVENTUAL ANOMALIA, EXPLIQUE LA NATURALEZA DEL DEFECTO Y DEVUELVA LA FICHA A LA TIENDA DONDE HA COMPRADO EL MUEBLE, QUE NOS LO HARA SEGUIR.

**WAARBORG :**

GELIEVE DE BIJHORENDE GARANTIEKAART MET EVENTUELE AARD EN OORZAAK VAN BESCHADIGINGEN NAAR UW WINKELIER TERUG TE STUREN, DIE ZE ONS ZAL DOORSUREN.

**ГАРАНТИЯ :**

ЕСЛИ ВЫ ВДРУГ ОБНАРУЖИЛИ ДЕФЕКТ МАТЕРИАЛА ИЛИ ПРОИЗВОДСТВА, ТОЧНО ОПИШИТЕ ДЕФЕКТ НА ЭТОМ ЛИСТЕ И ОБРАТИТЕСЬ В МАГАЗИН, В КОТОРОМ ВЫ КУПИЛИ МЕБЕЛЬ. ЭТОТ ДОКУМЕНТ БУДЕТ НЕМЕДЛЕННО НАМ ПЕРЕДАН И НАМИ РАССМОТРЕН.

NOM : \_\_\_\_\_ ADRESSE : \_\_\_\_\_  
\_\_\_\_\_

NATURE DU DEFAUT EVENTUEL : \_\_\_\_\_  
\_\_\_\_\_

**ORDRE DE DEBALLAGE DES COLIS  
UNPACKINGORDER OF THE PARCELS  
REIHENFOLGE BETREFFEND DAS AUSPACKEN DER KOLLIS  
DESEMBALAR LOS BULTOS EN ESTE ORDEN  
VOLGORDE VAN UITPAKKEN VAN DE KOLLIS  
ПОРЯДОК РАСПАКОВКИ ДЕТАЛЕЙ**

**REF. 241.160 : COMMODE 4 TIROIRS TROPIC**

NUMERO DE CONTROLE (OM):

(MERCİ DE COCHER, SUR CETTE FICHE, LE NUMERO DE PIECE ET LA REFERENCE COLIS FAISANT OBJET DE LA RECLAMATION)

**COLIS 1  
(REF.241.160)**

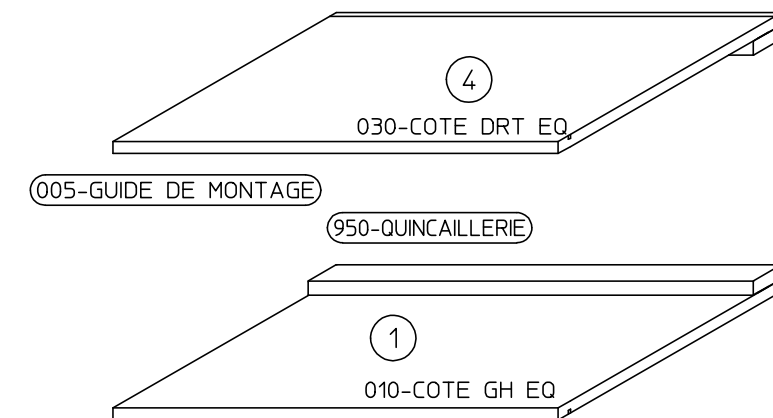

**COLIS 2  
(REF.241.161)**

