

GAMI

MONTANA

195 JUNIOR

473 ADULTE

COMMODE

4 TIROIRS

REF: 164

NOTICE DE MONTAGE: Il est très important que vous suiviez phase par phase les instructions de montage !
ASSEMBLY INSTRUCTIONS: It is very important that you follow step by step assembly instructions !
LAS INSTRUCCIONES: Es muy importante que sigan paso a paso las instrucciones !
MONTAGEPLAN: Het is zeer belangrijk de volgnummers van de handleiding te volgen !
MONTAGEANLEITUNG: Es ist sehr wichtig, dass Sie die Montageanleitung der Reihe nach verfolgen !
ISTRUZIONI DI MONTAGGIO: E' molto importante seguire attentamente e passo per passo le istruzioni di montaggio !
ИНСТРУКЦИИ ПО СБОРКЕ: Очень важно шаг за шагом точно следовать инструкции по сборке:
MONTAJ KÝLAVUZU: Montaj kılavuzunu sırası ile takip etmeniz çok önemlidir.

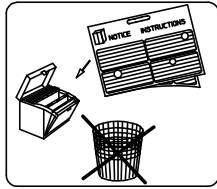
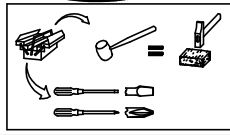
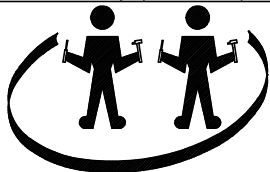
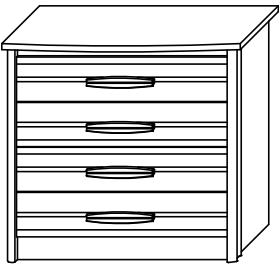
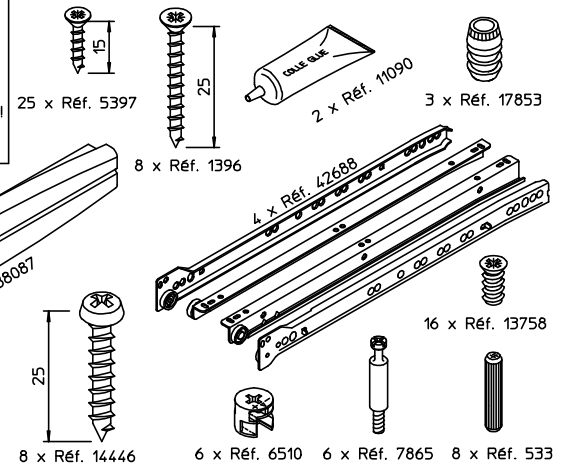

1 x Réf. 48330

8 x Réf. 12297

8 x Réf. 14446

6 x Réf. 6510

6 x Réf. 7865

8 x Réf. 533

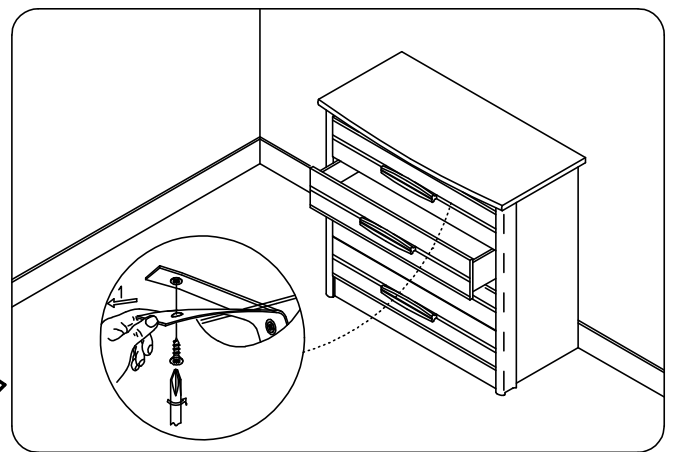
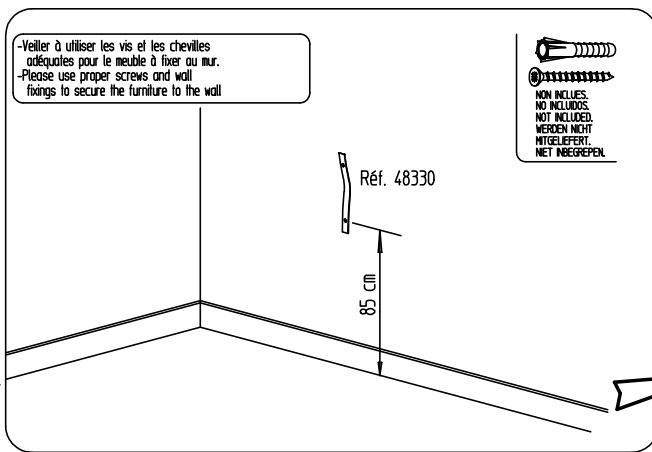
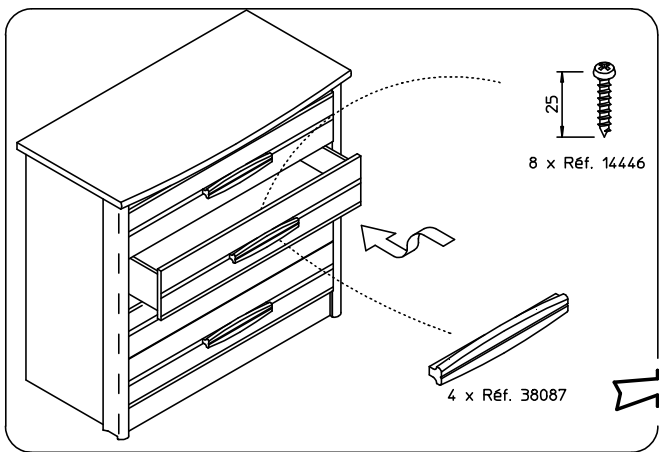
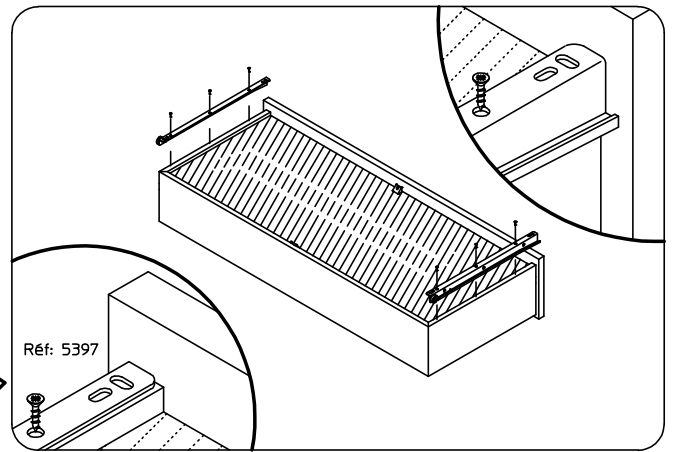
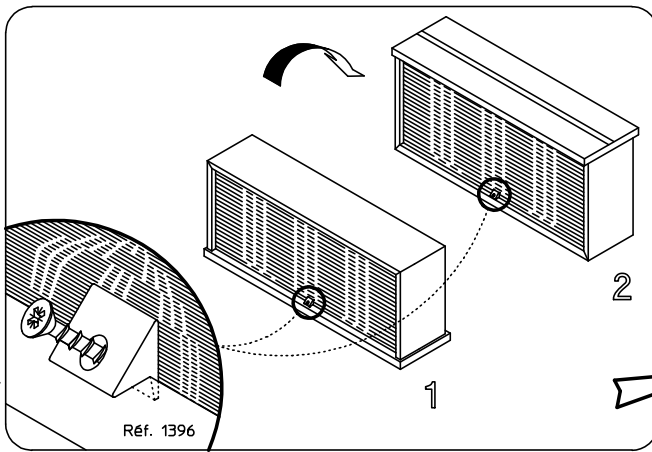
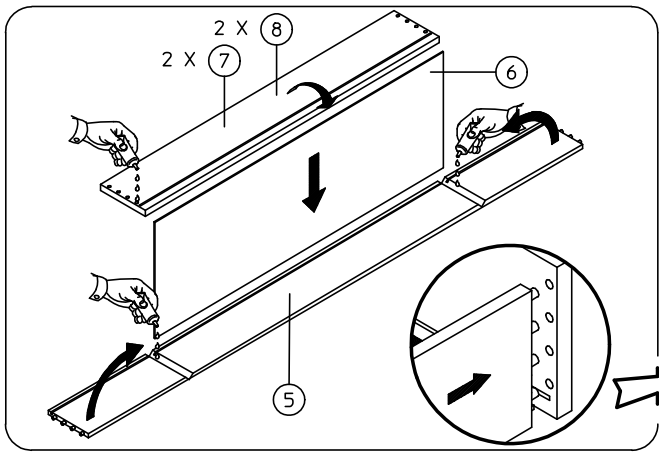
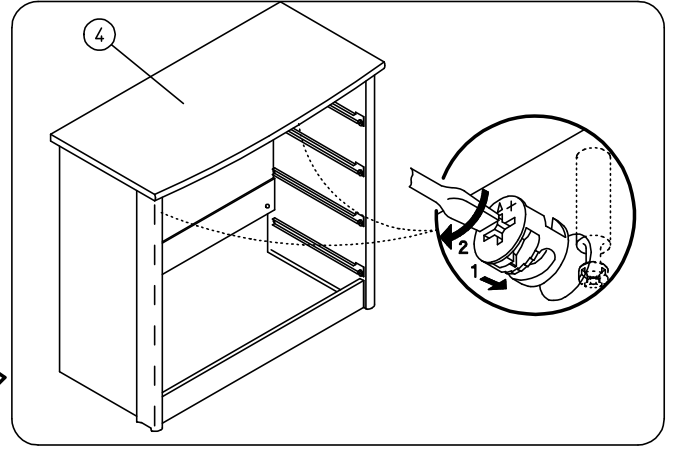
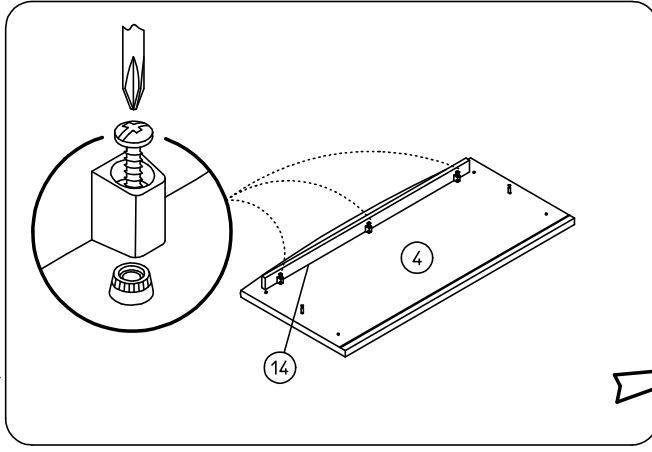
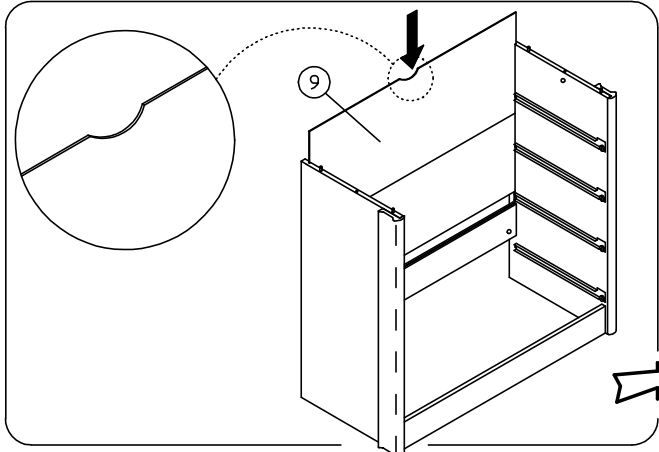
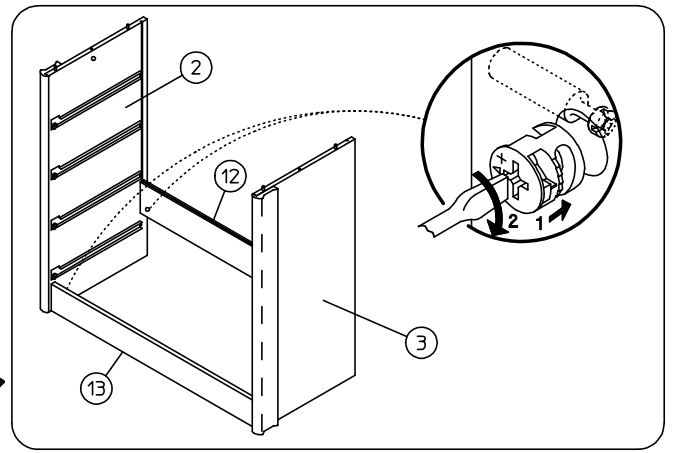
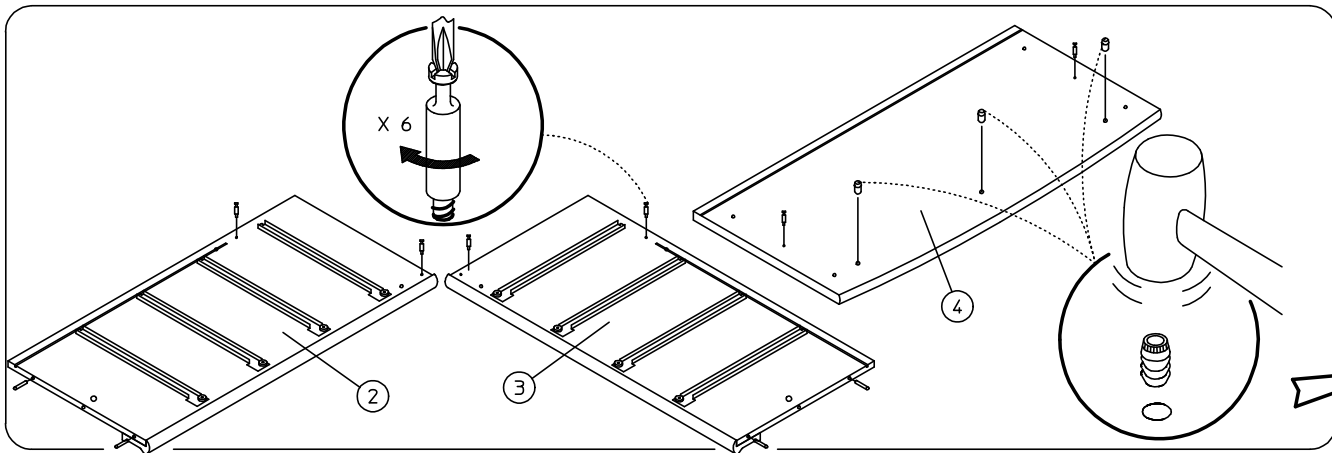
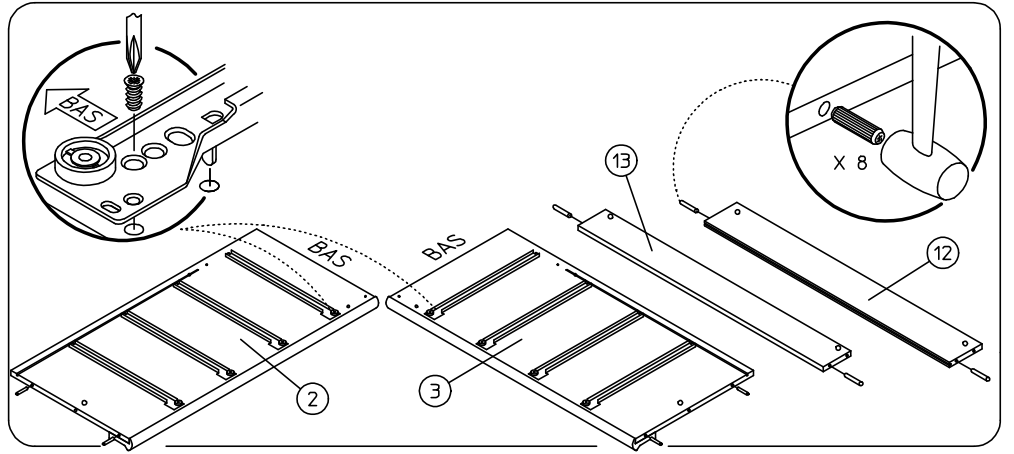
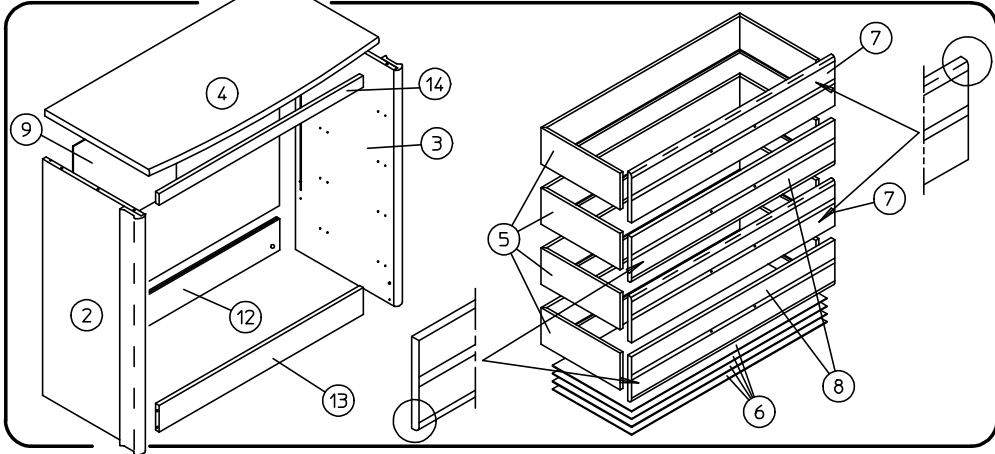

CONSEILS D'ENTRETIEN :

MELAMINES, LAQUES ET VERNIS SE NETTOIENT EXCLUSIVEMENT A L'AIDE D'EAU SAVONNEUSE.

HINTS ON CARE :

MELAMINE, ENAMELS AND VARNISHES ARE EXCLUSIVELY CLEANED WITH SUDSY WATER.

CONSEJOS PARA EL CUIDADO :

MELAMINA, LACADOS Y BARNIZADOS SE LIMPIAN EXCLUSIVAMENTE CON AGUA ENJABONADA.

ONDERHOUD :

VOOR LAK EN VERNIS ALLEEN MAAR EEN LICHT SOP GEBRUIKEN.

PFLEGEVORSCHRIFTEN :

MELAMINBESCHICHTUNGEN, LACKE UND FIRNISSE SIND NUR MITTELS SEIFENWASSER ZU REINIGEN.

MANUTENTIONE :

MELAMINATO, LACCHE E VERNICI SI PULISCONO ESCLUSIVAMENTE E SOLO CON ACQUA E SAPONE

СОВЕТЫ ПО УХОДУ ЗА МЕБЕЛЬЮ :

ПОКРЫТИЯ ИЗ МЕЛАМИНА, ЭМАЛИ ИЛИ ЛАКА МОЖНО ЧИСТИТЬ ТОЛЬКО МЫЛЬНОЙ ВОДОЙ.

BAKÝM İÇİN İPUÇU :

MELAMINE,BASKÝ VE CILALÝ YÜZEYLERİ TEMİZLER İKEN SADECE ARÝ SU KULLANÝNÝZ

GARANTIE :

SI VOUS CONSTATEZ UNE EVENTUELLE ANOMALIE, PRECISEZ LA NATURE DU DEFAUT SUR CETTE FICHE ET RETOURNEZ-LA AU MAGASIN QUI VOUS A VENDU LE MEUBLE. CE DOCUMENT NOUS SERA IMMEDIATEMENT TRANSMIS.

GARANTY :

IN THE UNLIKELY EVENT OF THERE BEING A MANUFACTURING OR MATERIAL DEFECT, PLEASE CONTACT THE RETAILER FROM WHOM YOU PURCHASED OUR FURNITURE WITHOUT DELAY. STEPS WILL THEN BE TAKEN TO TAKEN TO EFFECT EARLY REMEDIAL ACTION.

GARANTIA :

SI USTED OBSERVA ALGUNA EVENTUAL ANOMALIA, EXPLIQUE LA NATURALEZA DEL DEFECTO Y DEVUELVA LA FICHA A LA TIENDA DONDE HA COMPRADO EL MUEBLE, QUE NOS LO HARA SEGUIR.

WAARBORG :

GELIEVE DE BIJHORENDE GARANTIEKAART MET EVENTUELE AARD EN OORZAAK VAN BESCHADIGINGEN NAAR UW WINKELIER TERUG TE STUREN, DIE ZE ONS ZAL DOORSUREN.

GARANTIE :

SOLLTEN SIE EVENTUELL EINEN MANGEL FESTSTELLEN SO BITTEN WIR SIE, UNS DIESEN NACHSTEHEND ZU BESCHREIBEN UND DIESES BLATT IHREM LIEFERANTIEN ZUZUSENDEN.

GARANZIA :

SE TROVATE QUALCHE DISCREPANZA, SI PREGA DI SPECIFICARE LA NATURA DEL DIFETTO SU QUESTO MODULO E CONSEGNARLO AL NEGOZIO DOVE AVETE ACQUISTATO I MOBILI. QUESTO DOCUMENTO CI SARÀ TRASMESSE IMMEDIATAMENTE.

ГАРАНТИЯ :

ЕСЛИ ВЫ ВДРУГ ОБНАРУЖИЛИ ДЕФЕКТЫМАТЕРИАЛА ИЛИ ПРОИЗВОДСТВА, ТОЧНО ОПИШИТЕ ДЕФЕКТ НА ЭТОМ ЛИСТЕ И ОБРАТИТЕСЬ В МАГАЗИН, В КОТОРОМ ВЫ КУПИЛИ МЕБЕЛЬ. ЭТОТ ДОКУМЕНТ БУДЕТ НЕМЕДЛЕННО НАМ ПЕРЕДАН И НАМИ РАССМОТРЕН.

GARANTI :

ÝSTENMEYEN MALZEME VE/VEYA ÜRETİM HATALARÝ İLE KARŞILAŞTÝĐYNYZDA LÜTFEN ÜRÜNÜ SATÝN ALDÝĐYNYZ BAYII İLE TEMAS KURUNUZ.BU SIZE EN HÝZLÝ ÇÖZÜMÜ GETİRECEKTİR.

NOM / NAME : _____ ADRESSE / ADDRESS : _____

NATURE DU DEFAUT EVENTUEL / NATURE OF THE DEFECT IF ANY : _____

ORDRE DE DEBALLAGE DES COLIS
UNPACKINGORDER OF THE PARCELS
DESEMBALAR LOS BULTOS EN ESTE ORDEN
VOLGORDE VAN UITPAKKEN VAN DE KOLLIS
REIHENFOLGE BETREFFEND DAS AUSPACKEN DER KOLLIS
RISPETTARE L'ORDINE CRONOLOGICO PER L'APERTURA DEI PACCHI.
ПОРЯДОК РАСПАКОВКИ ДЕТАЛЕЙ
KOLILERIN AÇYLMA TALIMATY

NUMERO DE CONTROLE (OM):

(MERCİ DE COCHER, SUR CETTE FICHE, LE NUMERO DE PIECE ET LA REFERENCE COLIS FAISANT OBJET DE LA RECLAMATION)

(PLEASE CROSS ON THIS FITTING INSTRUCTION THE PIECE NUMBER AND THE PACK REFERENCE CORRESPONDING TO THE PIECE DAMAGED)

COLIS 1

(REF.195.164)
(REF.473.164)

005-GUIDE DE MONTAGE
FICHE CONTROLE

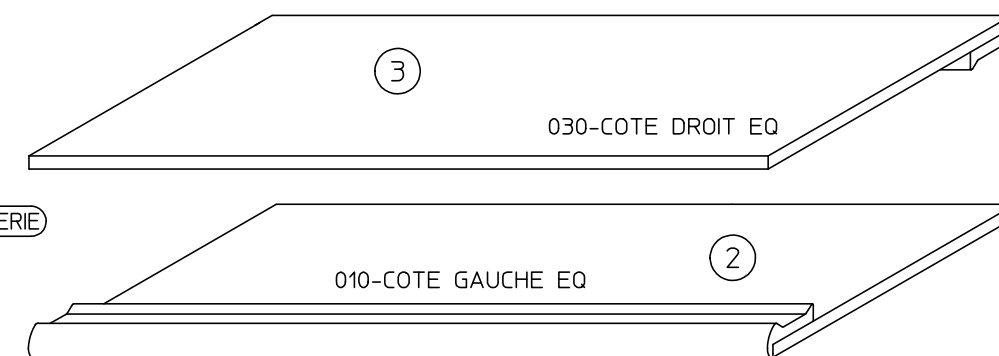
**COLIS 2**

(REF.195.165)
(REF.473.165)

