

# 107-JAZZ AULNE K17/U17-JAZZ CHENE

## CAISSON BOUT DE BUREAU L.45 REF. 252

- FR - **IMPORTANT** - A lire soigneusement - A conserver pour consultation ultérieure  
 - GB - **IMPORTANT** - Read carefully and keep for information later  
 - ES - **IMPORTANTE** - Leer atentamente y guardar para consultas posteriores  
 - NL - **BELANGRIJK**, Lees deze instructies aandachtig en bewaar ze zodat u ze later nog kunt raadplegen  
 - DE - **WICHTIGER HINWEIS**. Bitte lesen sie diese unterlagen aufmerksam durch und bewahren sie sie auf  
 - IT - **IMPORTANTE** - Da leggere attentamente e da conservare per una ulteriore consultazione.  
 - RU - **Это важно!** Внимательно прочитайте данную инструкцию и сохраните ее для того, чтобы в дальнейшем при необходимости к ней обращаться.  
 - TR - **ÖNEMLI**, Dikkatli şekilde okuyunuz ve daha sonra başvurmak üzere saklayiniz.

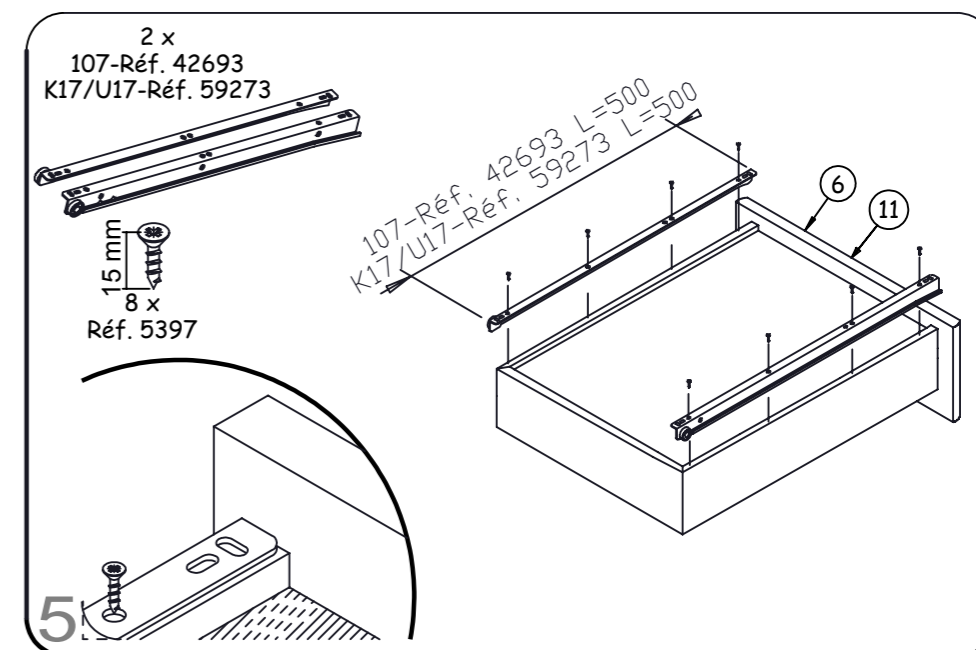

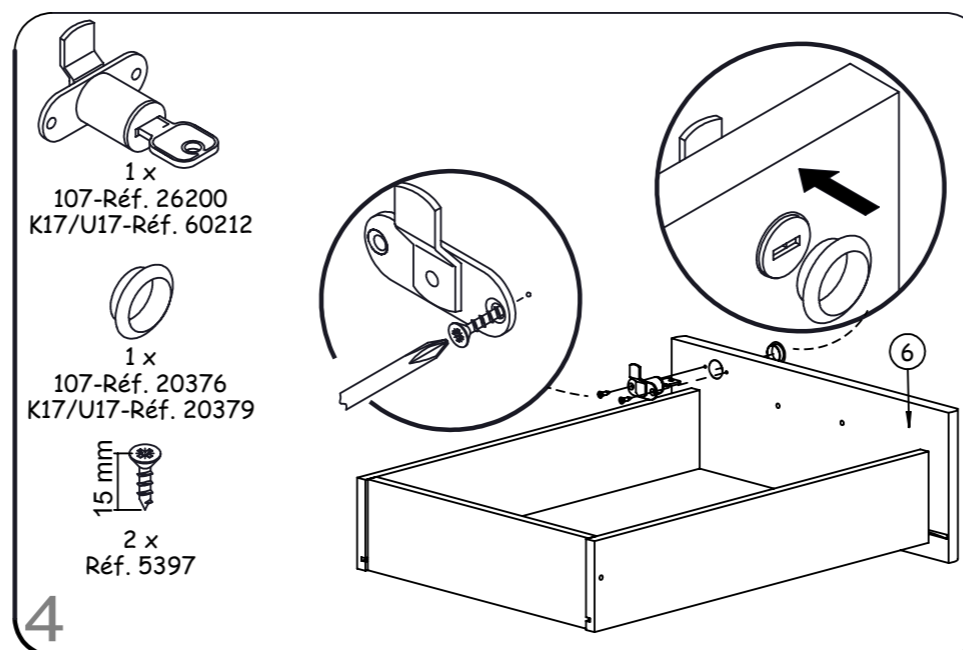
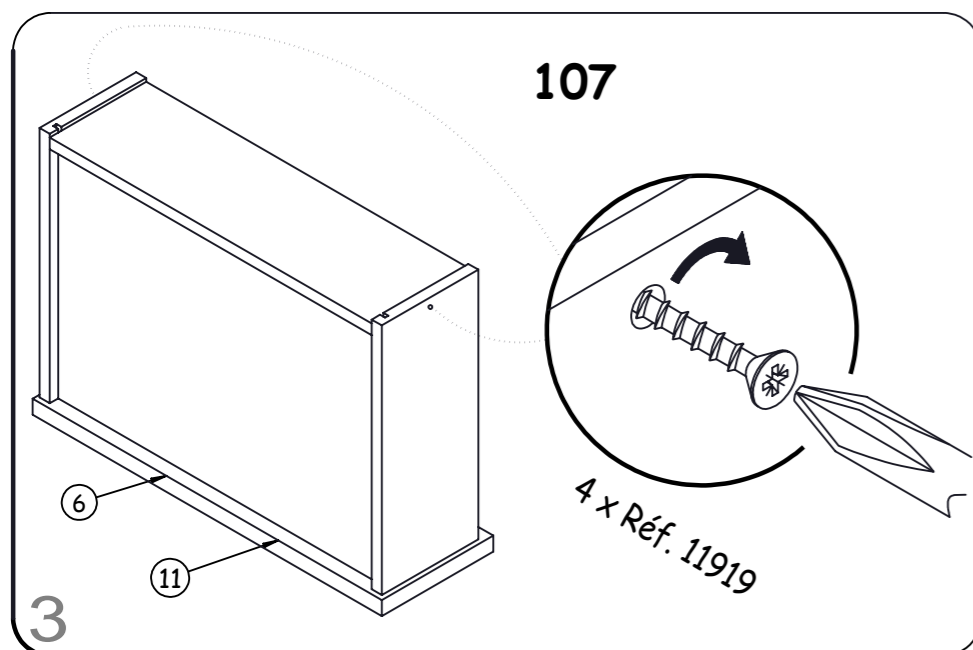
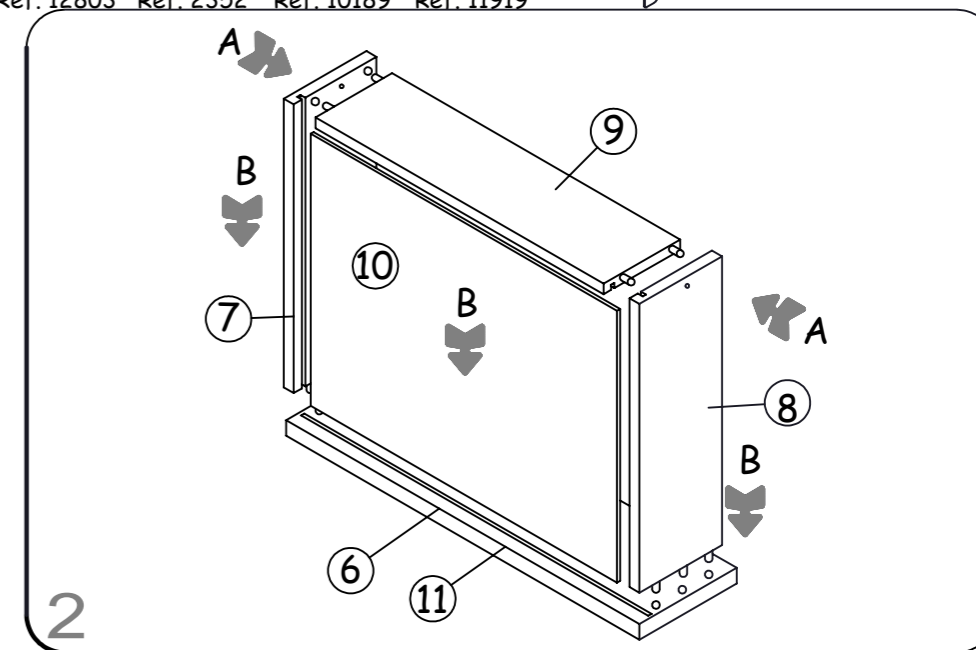
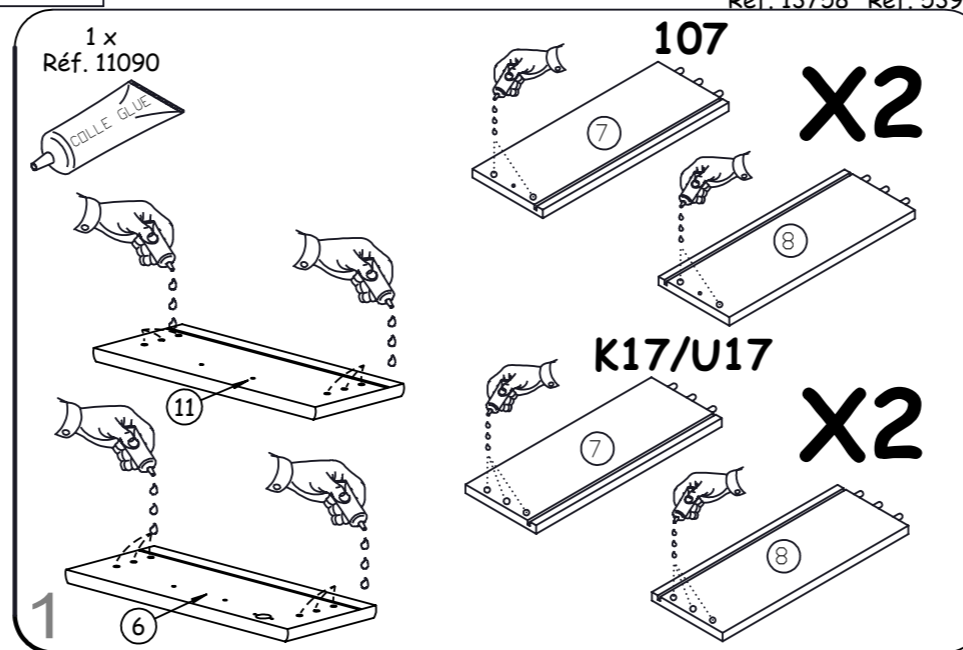
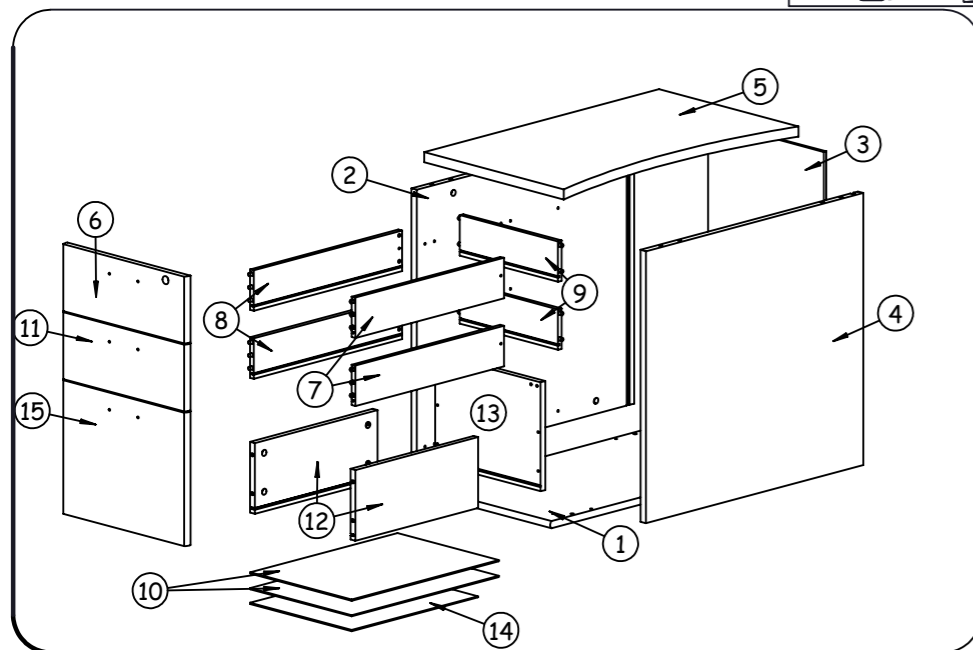
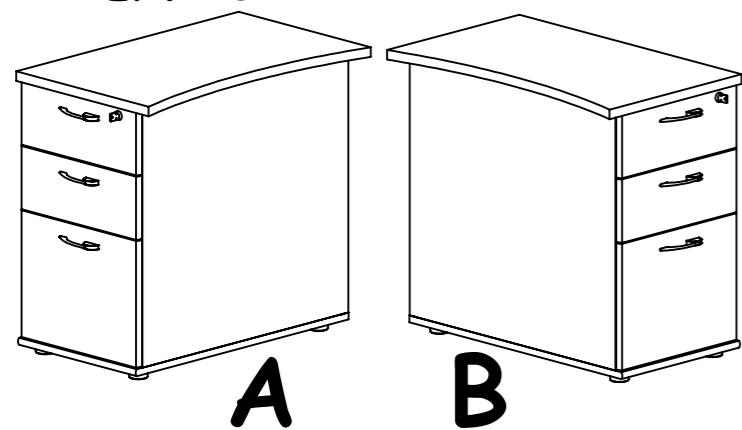
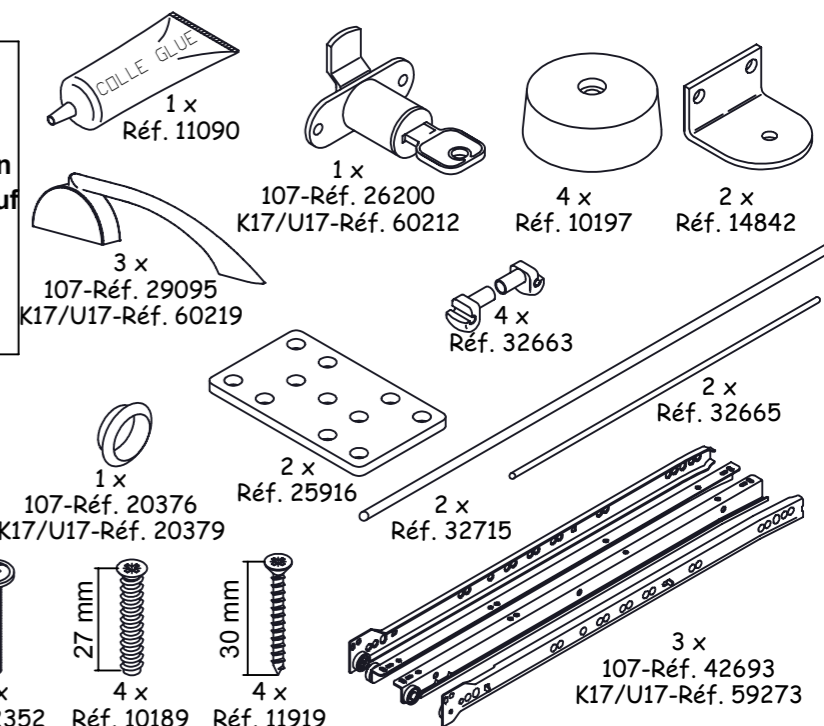
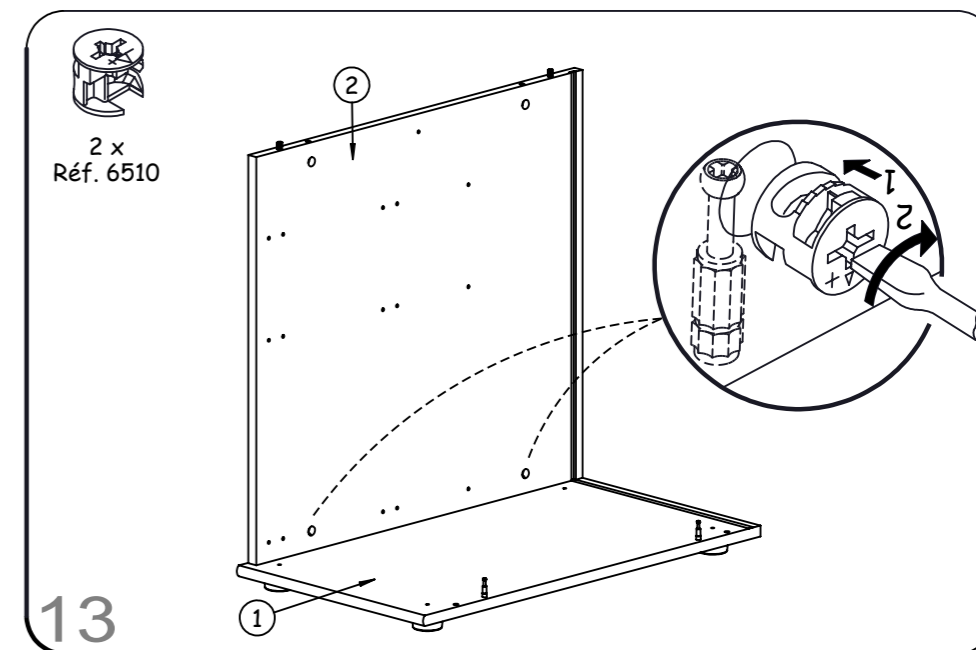
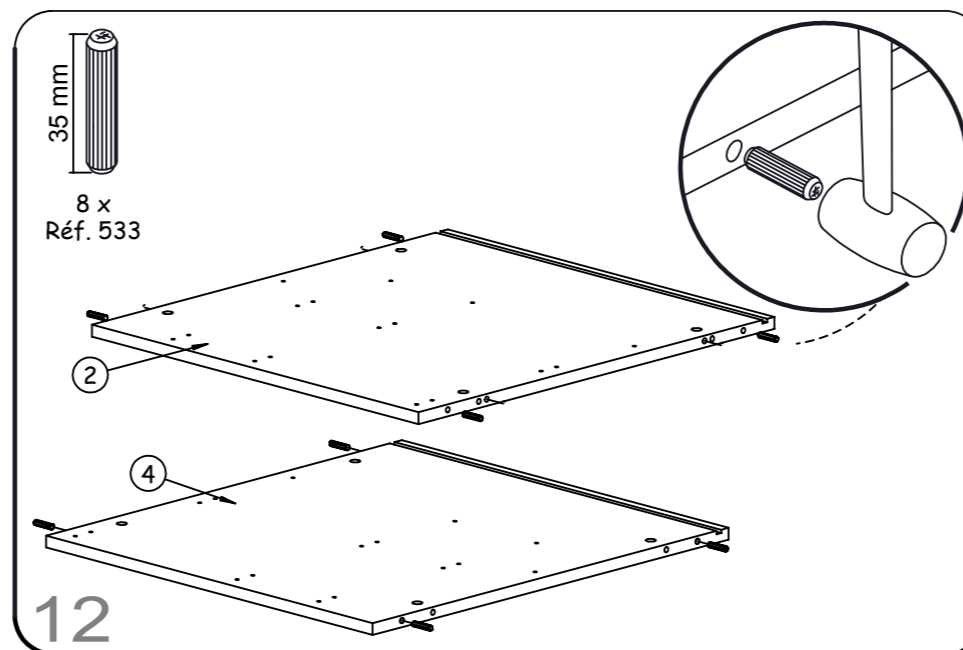
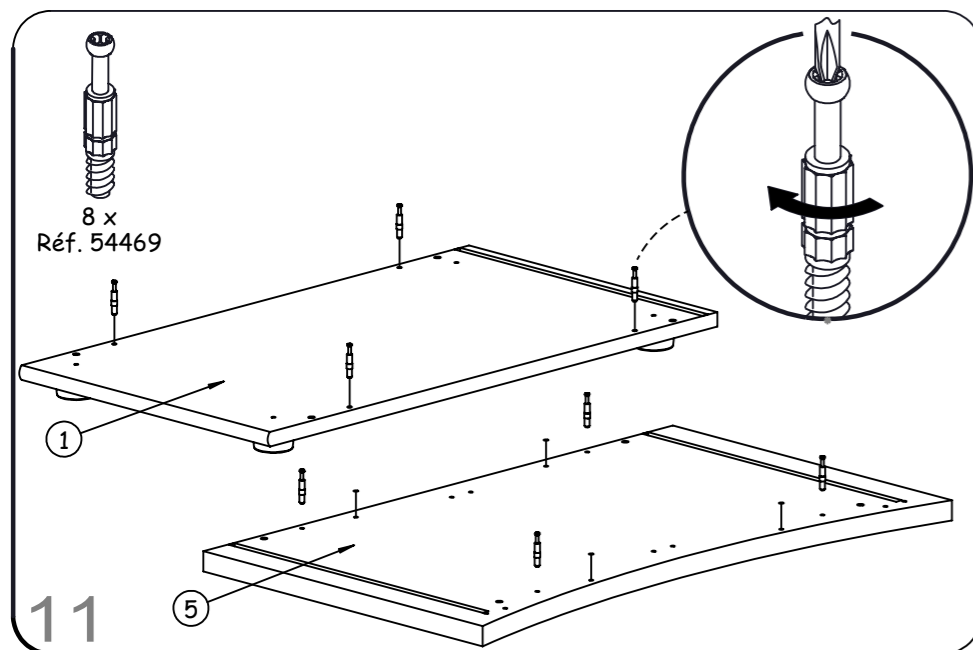
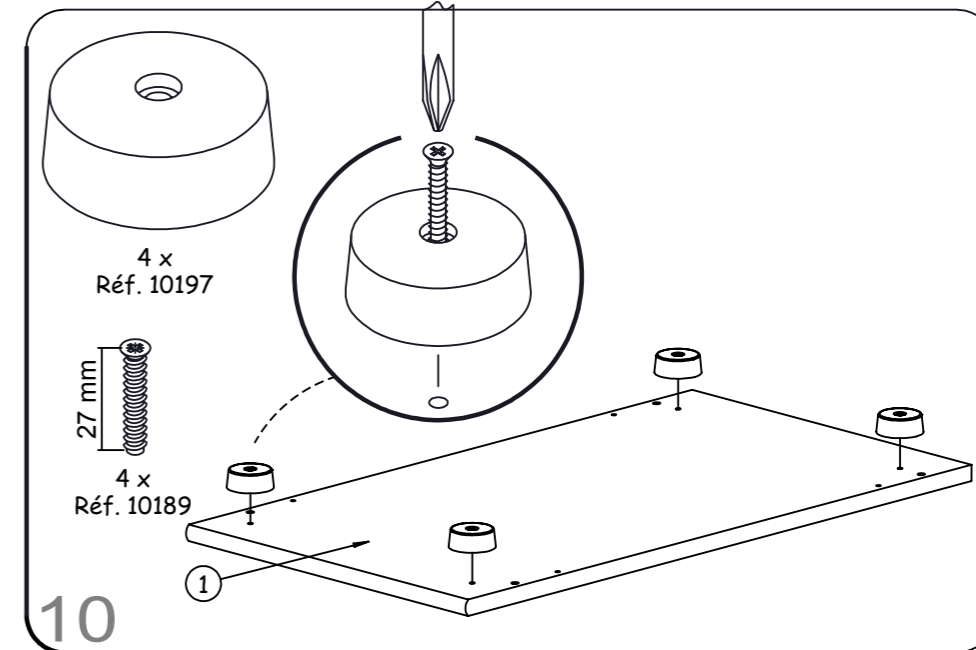
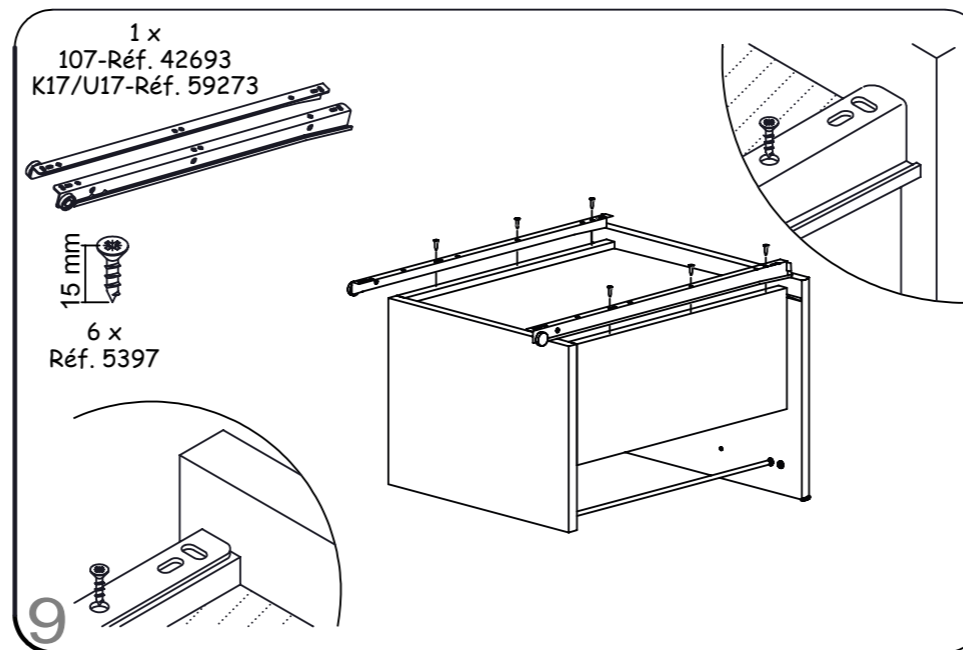
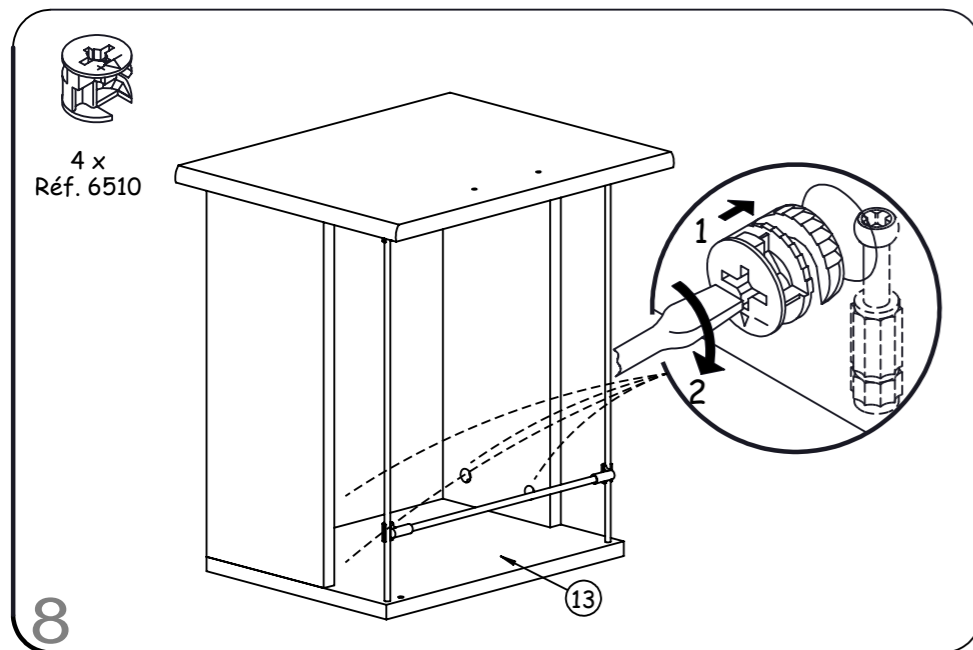
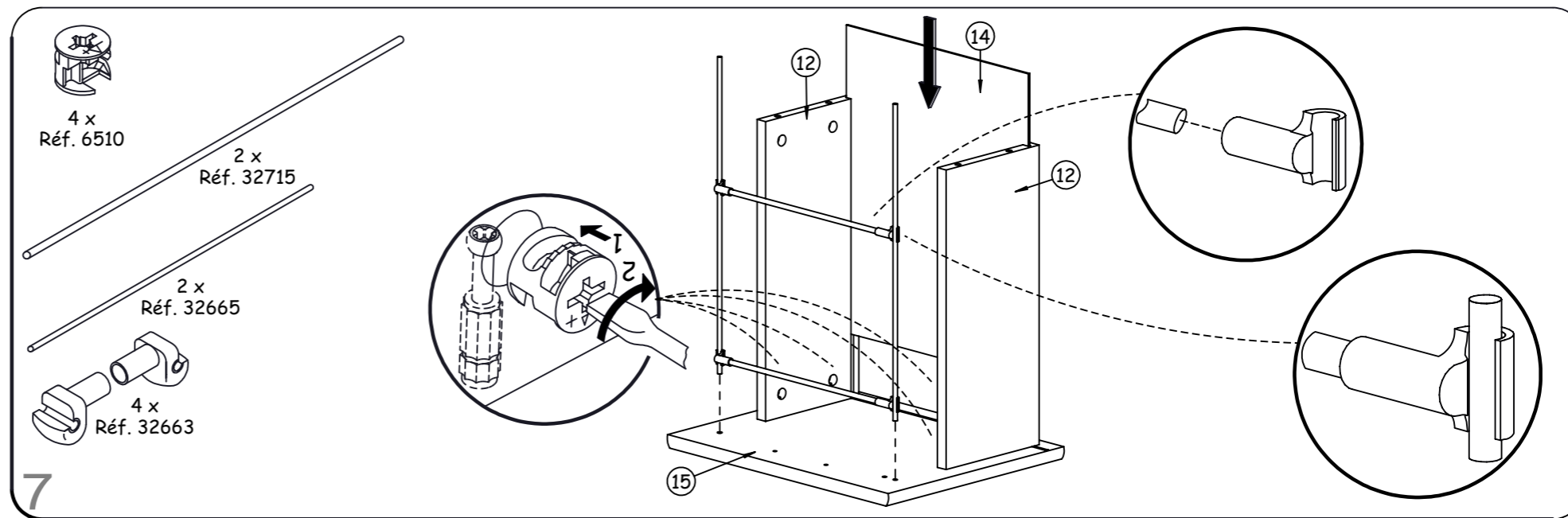
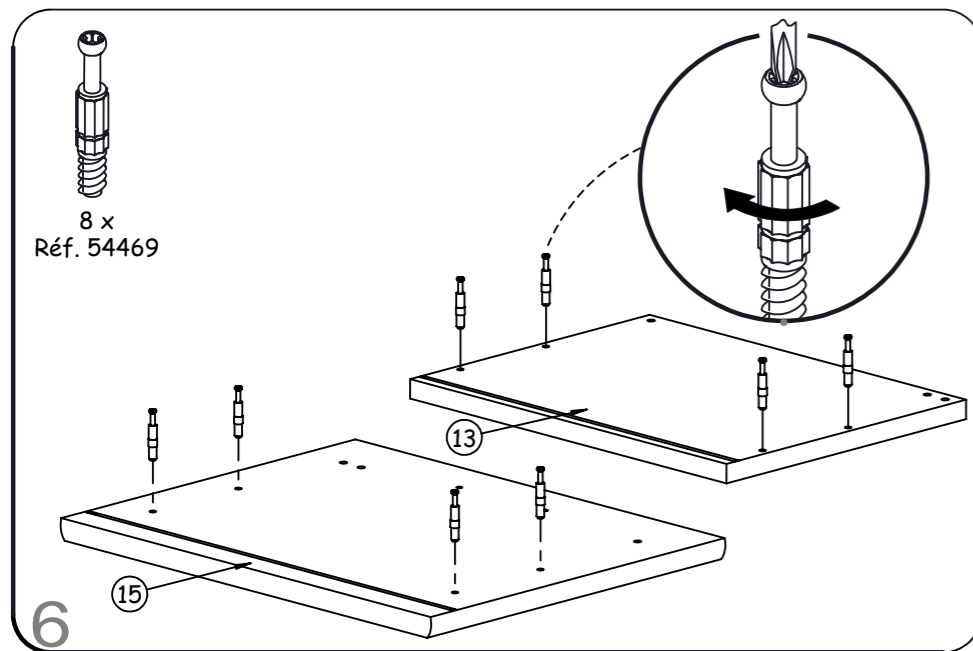

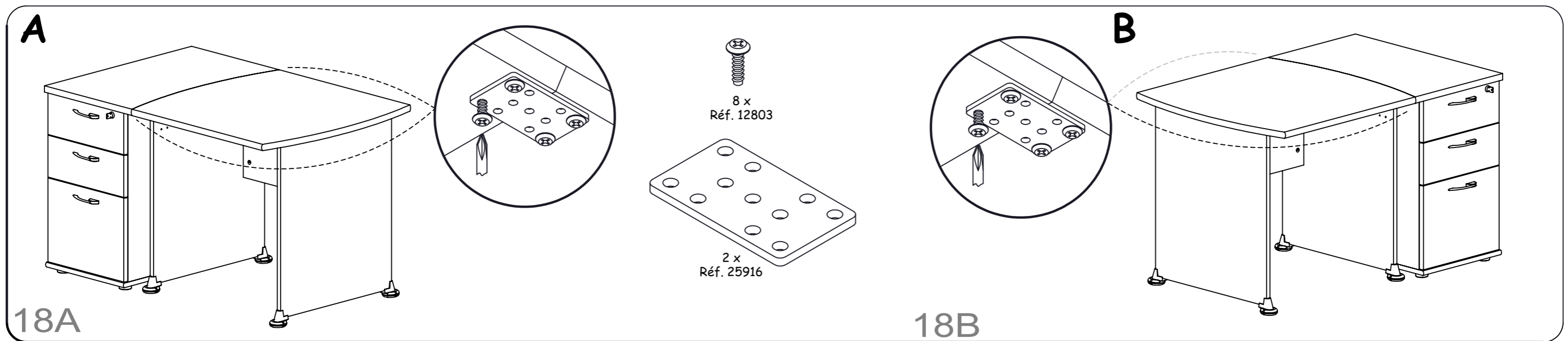
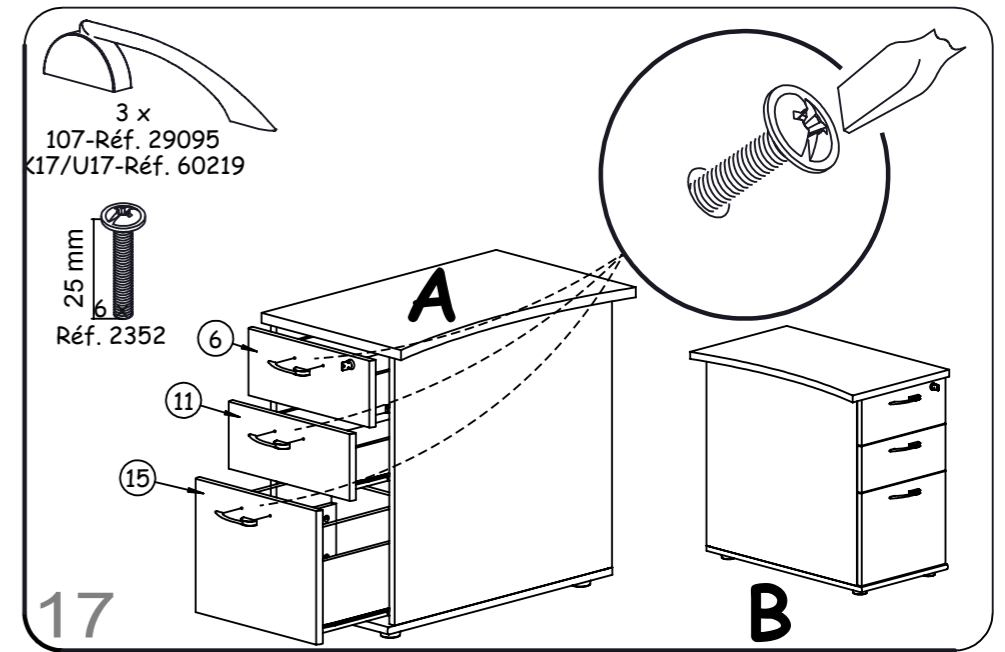
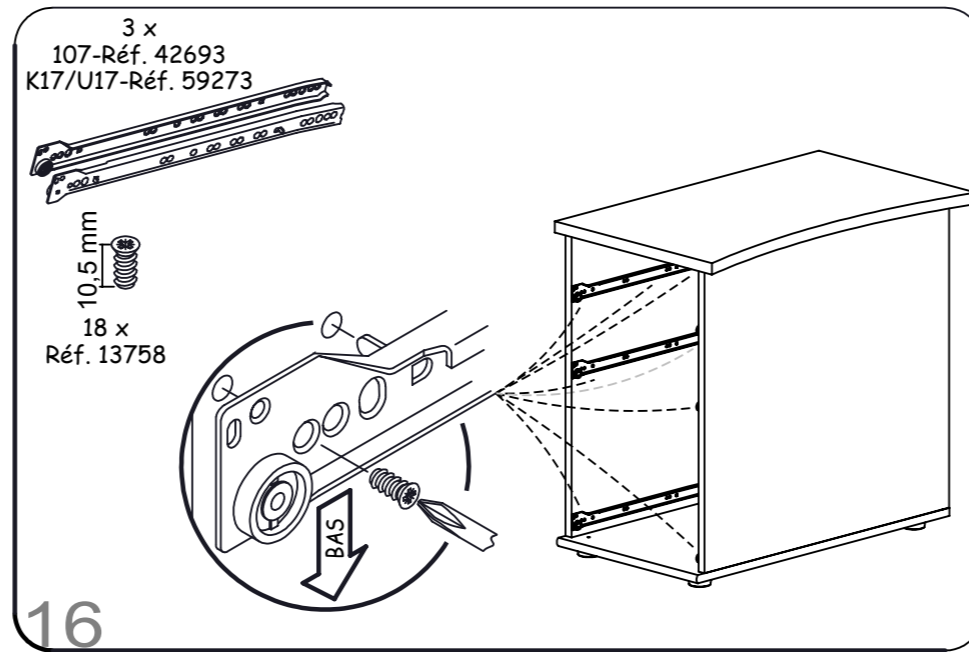
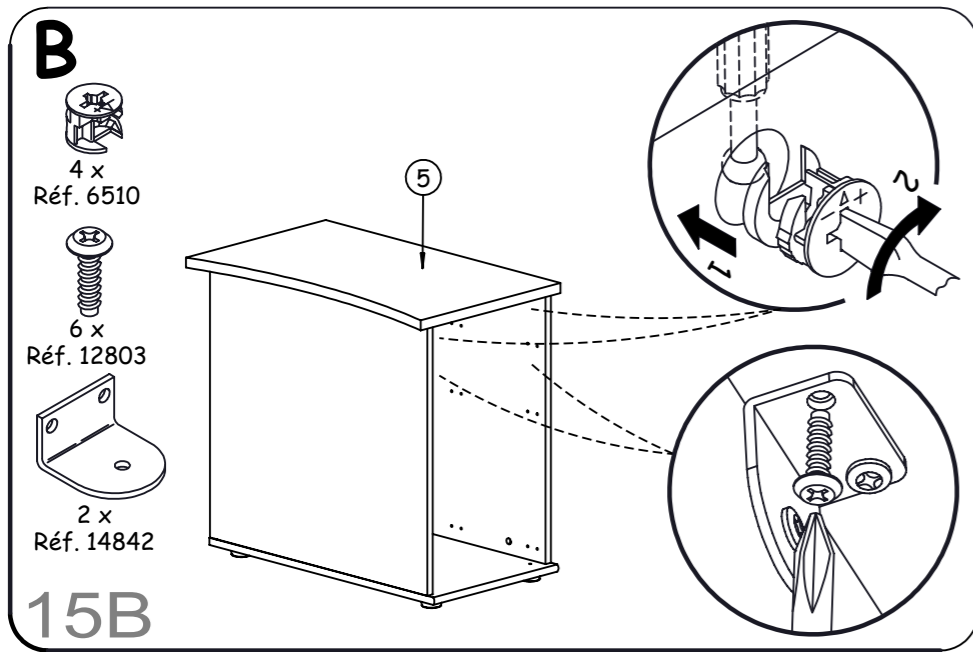
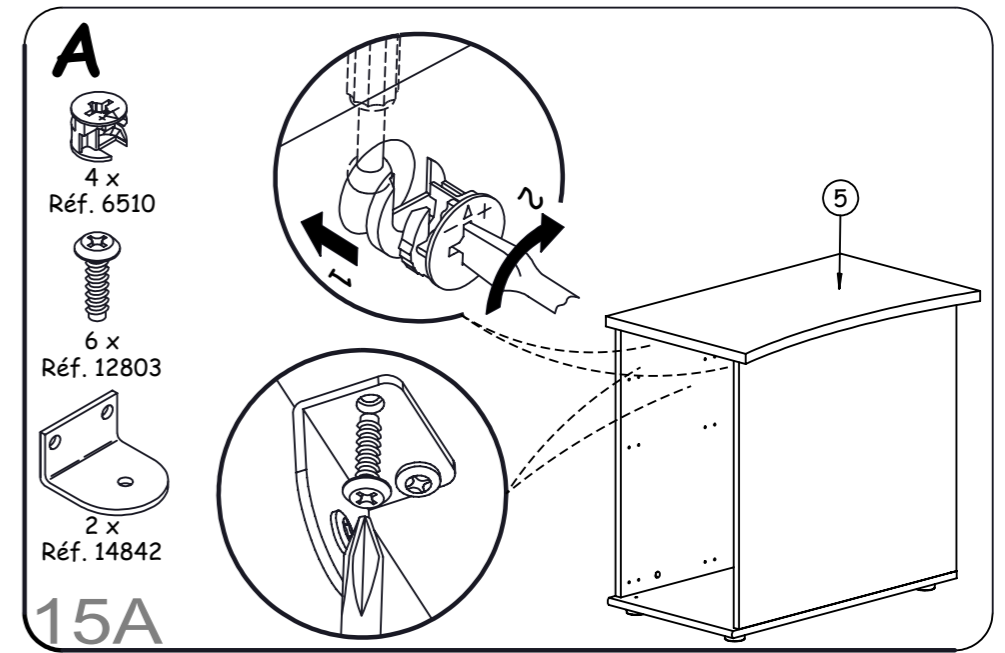
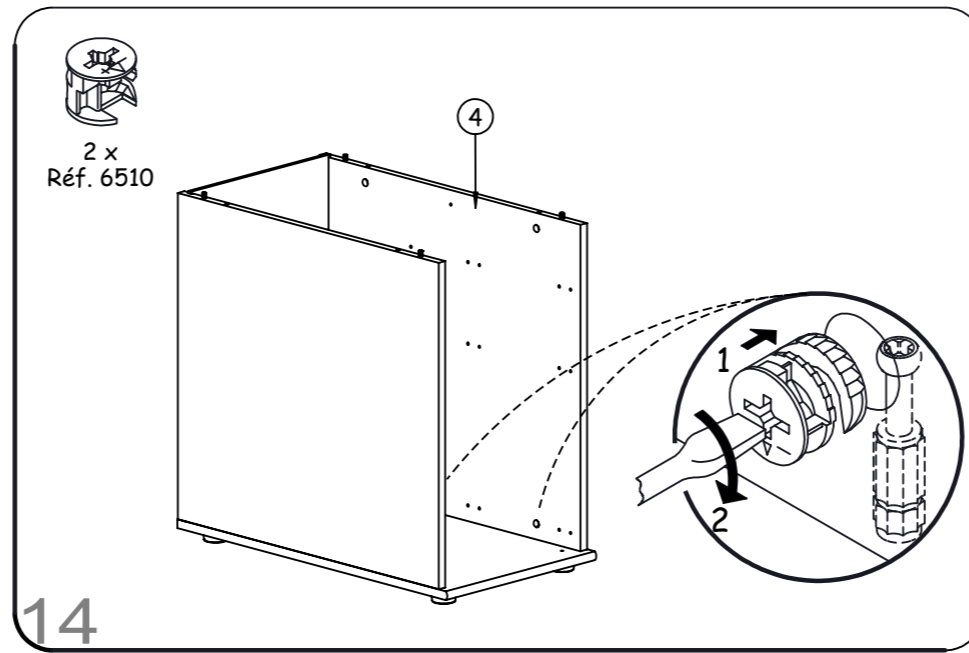
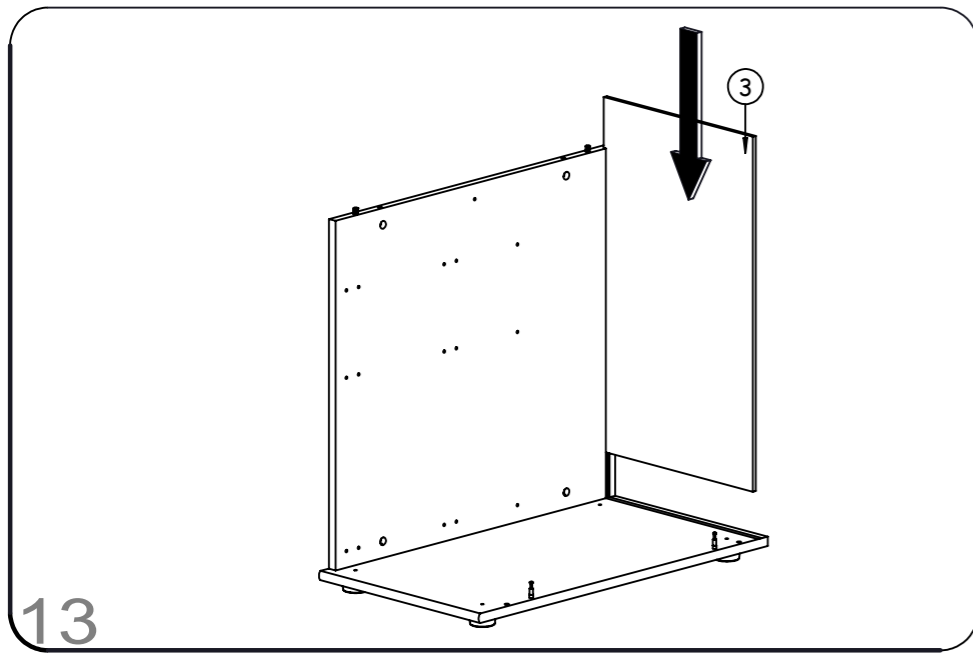

**CONSEILS D'ENTRETIEN :**

MELAMINES, LAQUES ET VERNIS SE NETTOIENT EXCLUSIVEMENT A L'AIDE D'EAU SAVONNEUSE.

**HINTS ON CARE :**

MELAMINE, ENAMELS AND VARNISHES ARE EXCLUSIVELY CLEANED WITH SUDSY WATER.

**CONSEJOS PARA EL CUIDADO :**

MELAMINA, LACADOS Y BARNIZADOS SE LIMPIAN EXCLUSIVAMENTE CON AGUA ENJABONADA.

**ONDERHOUD :**

VOOR LAK EN VERNIS ALLEEN MAAR EEN LICHT SOP GEBRUIKEN.

**PFLEGEVORSCHRIFTEN :**

MELAMINBESCHICHTUNGEN, LACKE UND FIRNISSE SIND NUR MITTELS SEIFENWASSER ZU REINIGEN.

**MANUTENZIONE :**

MELAMINATO, LACCHE E VERNICI SI PULISCONO ESCLUSIVAMENTE E SOLO CON ACQUA E SAPONE.

**СОВЕТЫ ПО УХОДУ ЗА МЕБЕЛЬЮ:**

ПОКРЫТИЯ ИЗ МЕЛАМИНА, ЭМАЛИ ИЛИ ЛАКА МОЖНО ЧИСТИТЬ ТОЛЬКО МЫЛЬНОЙ ВОДОЙ.

**BAKÝM İÇİN İPUCU :**

MELAMINE,BAŞKÝ VE CILALÝ YÜZEYLERİ TEMİZLER İKEN SADECE ARÝ SU KULLANÝNÝZ.

**GARANTIE :**

SI VOUS CONSTATEZ UNE EVENTUELLE ANOMALIE, PRECISEZ LA NATURE DU DEFAUT SUR CETTE FICHE ET RETOURNEZ-LA AU MAGASIN QUI VOUS A VENDU LE MEUBLE. CE DOCUMENT NOUS SERA IMMEDIATEMENT TRANSMIS.

**GARANTY :**

IN THE UNLIKELY EVENT OF THERE BEING A MANUFACTURING OR MATERIAL DEFECT, PLEASE CONTACT THE RETAILER FROM WHOM YOU PURCHASED OUR FURNITURE WITHOUT DELAY. STEPS WILL THEN BE TAKEN TO EFFECT EARLY REMEDIAL ACTION.

**GARANTIA :**

SI USTED OBSERVA ALGUNA EVENTUAL ANOMALIA, EXPLIQUE LA NATURALEZA DEL DEFECTO Y DEVUELVA LA FICHA A LA TIENDA DONDE HA COMPRADO EL MUEBLE, QUE NOS LO HARA SEGUIR.

**WAARBORG :**

GELIEVE DE BIJHORENDE GARANTIEKAART MET EVENTUELE AARD EN OORZAAK VAN BESCHADIGINGEN NAAR UW WINKELIER TERUG TE STUREN, DIE ZE ONS ZAL DOORSUREN.

**GARANTIE :**

SOLLTEN SIE EVENTUELL EINEN MANGEL FESTSTELLEN SO BITTEN WIR SIE, UNS DIESEN NACHSTEHEND ZU BESCHREIBEN UND DIESES BLATT IHREM LIEFERANTIEN ZUZUSENDEN.

**GARANZIA :**

SE TROVATE QUALCHE DISCREPANZA, SI PREGA DI SPECIFICARE LA NATURA DEL DIFETTO SU QUESTO MODULO E CONSEGNARLO AL NEGOZIO DOVE AVETE ACQUISTATO I MOBILI. QUESTO DOCUMENTO CI SARÀ TRASMESSO IMMEDIATAMENTE.

**ГАРАНТИЯ :**

Если вы вдруг обнаружили дефекты материала или производства, точно опишите дефект на этом листе и обратитесь в магазин, в котором вы купили мебель. этот документ будет немедленно нам передан и нами рассмотрен.

**GARANTI :**

ÝSTENMEYEN MALZEME VE/VEYA ÜRETİM HATALARÝ İLE KARŞILAŞTÝĐYNYZDA LÜTFEN ÜRÜNÜ SATYN ALDÝĐYNYZ BAYII İLE TEMAS KURUNUZ.BU SIZE EN HYZLY ÇÖZÜMÜ GETİRECEKTİR.

NOM / NAME: \_\_\_\_\_ ADRESSE / ADDRESS: \_\_\_\_\_

\_\_\_\_\_

NATURE DU DEFAUT EVENTUEL / NATURE OF THE DEFECT IF ANY : \_\_\_\_\_

\_\_\_\_\_

**ORDRE DE DEBALLAGE DES COLIS  
UNPACKING ORDER OF THE PARCELS  
DESEMBALAR LOS BULTOS EN ESTE ORDEN  
VOLGORDE VAN UITPAKKEN VAN DE KOLLIS  
REIHENFOLGE BETREFFEND DAS AUSPAKKEN DER KOLLIS  
RISPETTARE L'ORDINE CRONOLOGICO PER L'APERTURA DEI PACCHI.  
ПОРЯДОК РАСПАКОВКИ ДЕТАЛЕЙ  
KOLILERIN AÇYLMA TALIMATY**

NUMERO DE CONTROLE / CONTROL NUMBER :

(MERCİ DE COCHER, SUR CETTE FICHE, LE NUMERO DE PIECE ET LA REFERENCE COLIS FAISANT OBJET DE LA RECLAMATION)  
(PLEASE CROSS ON THIS FITTING INSTRUCTION THE PIECE NUMBER AND THE PACK REFERENCE CORRESPONDING TO THE PIECE DAMAGED)**COLIS 1**

(REF.107.252)

(REF.K17.252)

1 x Réf. 957200004 pour colis 107.252  
FOND TIROIR NR 342X424.5 AG1 x Réf. 957500057 pour colis K17.252  
FOND TIROIR GR 342X424 AG2 x Réf. 29449 pour colis 107.252  
TIR NOIR H-100 BDC-COTE GA. 5002 x Réf. 60215 pour colis K17.252  
TIR.TEXT H-100 BDC-COTE GA. 5002x Réf. 29448 pour colis 107.252  
TIR. NOIR H-100 BDC-COTE DR. 5002 x Réf. 60216 pour colis K17.252  
TIR.TEXT H-100 BDC-COTE DR. 5002 x Réf. 29447 pour colis 107.252  
TIR. NOIR H-100 DC-ARRIERE 3302 x Réf. 59882 pour colis K17.252  
TIR.TEXT H-100 DC-ARRIERE 3302 x Réf. 957200001 pour colis 107.252  
FOND TIROIR NR 341X495.5 AG2 x Réf. 957500058 pour colis 107.252  
FOND TIROIR GR 341X499 AG